

# Ventilation and ductwork

CIBSE Guide B2



# Ventilation and ductwork

## CIBSE Guide B2: 2016



The rights of publication or translation are reserved.  
No part of this publication may be reproduced, stored in a retrieval system or transmitted in any form or by any means without the prior permission of the Institution.

© May 2016 The Chartered Institution of Building Services Engineers London

Registered charity number 278104

ISBN 978-1-906846-75-6 (Print)  
ISBN 978-1-906846-76-3 (Online)

This document is based on the best knowledge available at the time of publication. However no responsibility of any kind for any injury, death, loss, damage or delay however caused resulting from the use of these recommendations can be accepted by the Chartered Institution of Building Services Engineers, the authors or others involved in its publication. In adopting these recommendations for use each adopter by doing so agrees to accept full responsibility for any personal injury, death, loss, damage or delay arising out of or in connection with their use by or on behalf of such adopter irrespective of the cause or reason therefore and agrees to defend, indemnify and hold harmless the Chartered Institution of Building Services Engineers, the authors and others involved in their publication from any and all liability arising out of or in connection with such use as aforesaid and irrespective of any negligence on the part of those indemnified.

Design, layout and typesetting by CIBSE Publications

Printed in Great Britain by Page Bros. (Norwich) Ltd., Norwich, Norfolk NR6 6SA

## Note from the publisher

This publication is primarily intended to provide guidance to those responsible for the design, installation, commissioning, operation and maintenance of building services. It is not intended to be exhaustive or definitive and it will be necessary for users of the guidance given to exercise their own professional judgement when deciding whether to abide by or depart from it.

Any commercial products depicted or described within this publication are included for the purposes of illustration only and their inclusion does not constitute endorsement or recommendation by the Institution.

# Foreword

Guide B provides guidance on the practical design of heating, ventilation and air conditioning systems. It represents a consensus on what constitutes relevant good practice guidance. This has developed over more than 70 years, with the Steering Groups for each edition of the Guide expanding and pruning the content to reflect the evolution of technology and priorities.

Since the last edition of Guide B in 2005, the European Energy Performance of Buildings Directive has been introduced. This requires national building energy regulations to be based on calculations that integrate the impact of the building envelope and the building services systems, formalising what was already recognised as good design practice. In addition, the use of voluntary energy efficiency and sustainability indicators has increased.

These changes have influenced the content of Guide B, but the emphasis remains on system design. The guidance in Guide B is not in itself sufficient to cover every aspect of the effective design of HVAC systems. Energy (and carbon emission) calculations will also be needed, and a range of other environmental criteria may be specified by the client. These may, for example, include whole-life costing or assessments of embodied energy or carbon. The balance between building fabric measures and the energy efficiency of HVAC systems is important, as is the balance between energy use for lighting and for heating, ventilation and cooling. More detailed information on energy efficiency and sustainability can be found in Guides F and L respectively. The Guide does not attempt to provide step by step design procedures: these can be found in appropriate textbooks.

## Structure of the Guide

Guide B deals with systems to provide heating, ventilation and air conditioning services, and is divided into several chapters which are published separately. It will usually be necessary to refer to several — perhaps all — chapters since decisions based on one service will commonly affect the provision of others.

- Chapter B0: *Applications and activities* focuses on how different types of building and different activities within buildings influence the choice of system. This chapter is not available in printed form, but can be downloaded from the CIBSE website. For many activities and types of building, more detailed design information is available in specialist guidance.

Chapters B1 to B4 address issues relating to specific services. There are usually several possible design solutions to any situation, and the Guide does not attempt to be prescriptive but rather to highlight the strengths and weaknesses of different options.

- B1: *Heating*, including hot water systems and an appendix on hydronic systems, which is also applicable to chilled water systems
- B2: *Ventilation and ductwork*
- B3: *Air conditioning and refrigeration*
- B4: *Noise and vibration control for building services systems* (applicable to all systems)

When all chapters have been published, an index to the complete Guide B will be made available.

The focus is on application in the UK: though many aspects of the guidance apply more generally, this should not be taken for granted. The level of detail provided varies: where detailed guidance from CIBSE or other sources is readily available, Guide B is relatively brief and refers to these sources. Examples of this are the treatment in the Guide of low carbon systems such as heat pumps, solar thermal water heating and combined heat and power. On-site energy generation such as wind power and photovoltaics are not covered.

Regulatory requirements are not described in detail in the Guide – the information varies between jurisdictions and is liable to change more rapidly than the Guide can be updated. Instead, the existence of regulations is sign-posted and their general scope explained. Sometime example tables are shown, but readers should note that these are simply examples of the type of requirement that is imposed and may not be current.

While there is some discussion of relative costs, no attempt is made to provide detailed cost figures as these are too project-specific and variable with time and location.

Roger Hitchin  
Chair, CIBSE Guide B Steering Committee

## Guide B2 Steering Committee

Peter Warren (Chair)	Brunel University London
Wayne Aston	Keysource Ltd
Nick Barnard	Low Carbon Comfort
Colin Biggs	Nuaire
Craig Booth	Icevent
Eric Curd	Independent Environmental Services Professional
Justin Davies	Kingspan Insulation
Alan Green	Trox UK Ltd
Danny Hall	Norman Disney & Young
Jon Hill	Polypipe Insulation
Roy Jones	Gilberts (Blackpool) Ltd
Ray Kirby	Brunel University London
Martin Liddament	VEETECH Ltd
Peter Rogers	DPL Kitchen Ventilation
Wander Ter Kiule	Waterloo
Paul White	Advanced Smoke Group Ltd

## Referees

John Armstrong	Armville Consultancy
Steve Irving	AECOM
Maria Kolokotroni	Brunel University London

## Acknowledgements

The Committee would like to acknowledge the particular contribution of Martin Liddament as technical author and in processing of peer review comments.

Permission to reproduce extracts from British Standards is granted by BSI Standards Ltd. British Standards can be obtained in pdf or hard copy formats from BSI online shop: [www.bsigroup.com/Shop](http://www.bsigroup.com/Shop) or by contacting BSI Customer Services for hardcopies only: tel: +44 (0)20 8996 9001, e-mail: [cservices@bsigroup.com](mailto:cservices@bsigroup.com).

Public information is reproduced under Open Government Licence v2.0.

## Editor

Ed Palmer

## Editorial Manager

Ken Butcher

## CIBSE Technical Director

Hywel Davies

## CIBSE Head of Knowledge

Nick Peake

# Contents

<b>2.1</b>	<b>Introduction</b>	<b>2-1</b>
2.1.1	Introduction	2-1
2.1.2	Scope	2-1
2.1.3	Definitions	2-1
2.1.4	Energy and carbon considerations	2-3
2.1.5	System costing	2-3
<b>2.2</b>	<b>Design criteria</b>	<b>2-4</b>
2.2.1	Introduction	2-4
2.2.2	Contaminant control	2-8
2.2.3	Fresh air supply rates	2-9
2.2.4	Ventilation for thermal comfort	2-10
2.2.5	Humidity	2-10
2.2.6	Ventilation to avoid interstitial condensation	2-10
2.2.7	Air movement: limiting air velocities	2-11
2.2.8	Air distribution	2-11
2.2.9	Noise	2-12
<b>2.3</b>	<b>Systems</b>	<b>2-12</b>
2.3.1	Introduction	2-12
2.3.2	Ventilation systems	2-13
2.3.3	Filtration systems	2-25
2.3.4	Ventilation heat recovery systems	2-30
2.3.5	Duct systems	2-34
2.3.6	Ventilation control systems	2-48
<b>2.4</b>	<b>System design</b>	<b>2-52</b>
2.4.1	Introduction	2-52
2.4.2	Designing for natural ventilation	2-52
2.4.3	Mechanical ventilation design	2-58
2.4.4	Mixed-mode ventilation design	2-63
2.4.5	Ductwork principles of design	2-65
2.4.6	Ventilation design calculation techniques	2-71
2.4.7	Ventilation design measurement techniques	2-75
<b>2.5</b>	<b>Other design considerations</b>	<b>2-79</b>
2.5.1	Introduction	2-79
2.5.2	Noise	2-79
2.5.3	Fire and smoke protection	2-81
2.5.4	Air leakage	2-84

<b>2.6</b>	<b>Equipment</b>	<b>2-87</b>
2.6.1	Fans	2-87
2.6.2	Air control units	2-92
2.6.3	Mixing boxes	2-94
2.6.4	Air terminal devices: diffusers and terminals	2-94
2.6.5	Ventilation air intake and discharge points	2-94
2.6.6	Process exhaust hoods	2-96
2.6.7	Duct equipment	2-98
2.6.8	Ductwork connections	2-103
2.6.9	Natural ventilation equipment	2-106
<b>2.7</b>	<b>Commissioning, operation and maintenance</b>	<b>2-111</b>
2.7.1	Testing and commissioning	2-111
2.7.2	Maintenance and cleaning	2-116
	<b>References</b>	<b>2-122</b>
	Appendix 2.A1: Recommended sizes for ductwork	2-127
	Appendix 2.A2: Space allowances	2-129
	Appendix 2.A3: Maximum permissible air leakage rates	2-131
	Appendix 2.A4: Methods of fire protection	2-131
	Appendix 2.A5: Example calculations	2-132
	Appendix 2.A6: Techniques for assessment of ventilation	2-144
	<b>Index</b>	<b>2-146</b>

# 2 Ventilation and ductwork

## 2.1 Introduction

### 2.1.1 Introduction

Ventilation is the process by which fresh air is provided to occupants and concentrations of potentially harmful pollutants are diluted and removed from a space. It is also used to cool a space and as a mechanism to distribute thermally conditioned air for heating and cooling. It is a fundamental component of building services design since it plays a major role in the comfort, health and productivity of occupants. In addition, ventilation can contribute significantly to a building's energy load and, in some cases, can account for 50 per cent or more of total heating or cooling loss. To stem energy loss from uncontrolled air change there is growing demand for airtightness combined with demand-controlled ventilation and heat recovery.

In large buildings, the ventilation system can be extremely complex and is invariably integrated with the heating and cooling system. Hence there is a strong connection between ventilation, heating and cooling systems, building envelope, fire protection and structural design issues (Thomas, 1999). This impinges on the whole-life costs (BSRIA, 2008) and performance (Allard, 2001) of buildings. Since building services are required to operate throughout the life of the building, their operating costs are a very significant element of the whole-life costs of the system.

For all these reasons, there is a need for up-to-date guidance on the design of ventilation systems. The overall process of design development, from the initial outline design through to system selection and detailed equipment specification, is summarised schematically in Figure 2.1. Cooling systems are separately covered by CIBSE Guide B3 (2016a) and heating systems are covered in CIBSE Guide B1 (2016b).

### 2.1.2 Scope

This guide is intended to be used by practising designers who hold a basic knowledge of the fundamentals of building physics and building services engineering.

Section 2.2 sets out the criteria for the design of ventilation systems, covering the contribution of ventilation to providing a safe and comfortable indoor environment, including indoor air quality, thermal comfort and noise. This chapter should be read in conjunction with chapter 1 of CIBSE Guide A (2015a).

Section 2.3 reviews the principal methods of providing ventilation: natural, mechanical and mixed-mode systems. It also describes the basic principles of related systems for air distribution, filtration, heat recovery and control.

Section 2.4 sets out the principles for designing natural, mechanical and mixed-mode systems and includes the design of ductwork, calculation techniques and methods of measuring the performance of ventilation systems.

Section 2.5 discusses other design considerations closely related to ventilation and covers noise, air leakage, fire and smoke protection. Noise and fire protection are dealt with in more detail in CIBSE Guides B4 (2016c) and G (CIBSE, 2014) respectively.

Section 2.6 covers the components of a ventilation system and includes fans, air control units, mixing boxes, terminal devices, extract hoods and duct equipment. Also included is equipment for natural ventilation.

Section 2.7 covers the important areas of testing, commissioning, maintenance and cleaning.

### 2.1.3 Definitions

The meaning of key terms used in this Guide are summarised below.

- *Natural ventilation*: this is the process by which airflow through ventilation openings is driven by the natural driving forces of wind (wind effect) and temperature difference (stack effect). Natural ventilation systems are described in section 2.3.2.2.
- *Mechanical ventilation*: these systems incorporate fans and control systems to drive the ventilation process. They are thus able to provide ventilation irrespective of the availability or suitability of natural forces. In many countries large buildings including city centre offices, public buildings and shopping malls are almost universally mechanically ventilated. In addition to providing fresh air, mechanical systems are also often used to distribute thermally conditioned air as part of the building's heating and cooling (air conditioning) system. There are various configurations of mechanical ventilation; these are described in section 2.3.2.3.
- *Mixed-mode or hybrid ventilation*: this utilises a combination of both natural and mechanical ventilation. The various modes of operation are described in section 2.3.2.4.

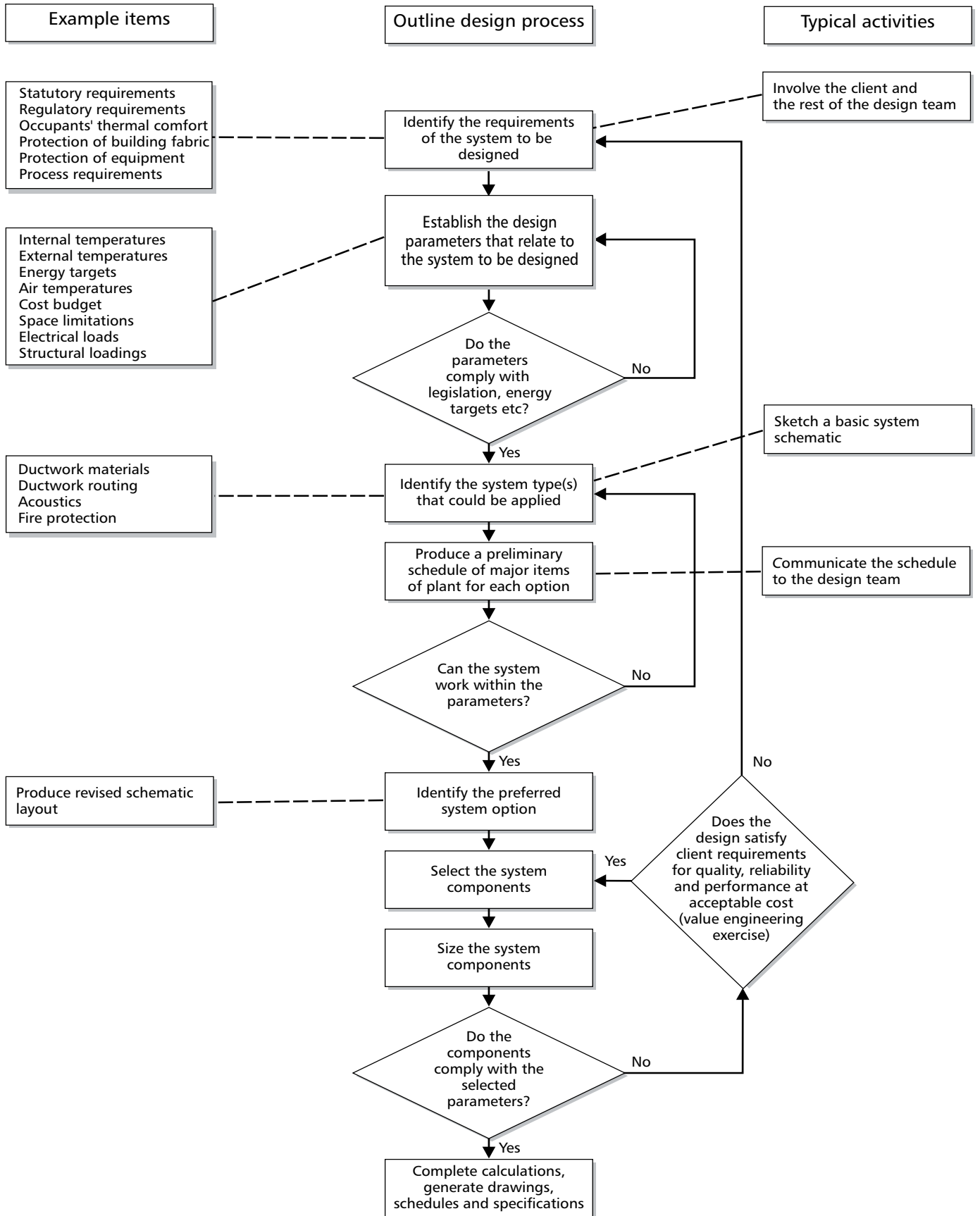

This publication is supplied by CIBSE for the sole use of the person making the download. The content remains the copyright of CIBSE.

Figure 2.1 Outline of the ventilation design process

- *Air change rate*: this is the ventilation rate in m<sup>3</sup>/h divided by the volume in m<sup>3</sup> of the enclosed space expressed in air changes per hour (ACH).
- *Air infiltration*: this is defined as the air ingress, under ambient conditions, that enters a building through adventitious cracks and gaps in the building envelope. The corresponding air loss is defined as air exfiltration.
- *Airtightness*: this is a measure of the air leakage rate through the building envelope for a given test pressure (typically at 50 Pa) (see section 2.4.7.2).
- *Blower door*: a device for pressure testing building airtightness.
- *Contaminant removal efficiency*: this is a term used to describe the efficiency of the removal of contaminant in a space by ventilation. It can relate to the space as a whole or to individual locations.
- *Dilution ventilation*: see ‘mixing (or dilution) ventilation’.
- *Displacement ventilation*: this is a mechanism by which fresh air is introduced to a location without mixing the fresh incoming air with the room air.
- *Heat recovery*: a process by which sensible ‘dry’ heat from the exhaust air supply is recovered and normally used to pre-heat the supply air (see section 2.3.4). Latent heat can also be recovered with some systems.
- *Latent heat recovery*: a process by which latent heat from moisture in air is recovered.
- *Mixing (or dilution) ventilation*: a system by which incoming fresh air is thoroughly mixed with the air already in a space. This is a common approach for air-driven heating and cooling systems.
- *Percentage persons dissatisfied (PPD) thermal comfort parameter*: the percentage of people expressing dissatisfaction with the thermal environment in which they are exposed (e.g. too hot or too cold).
- *Predicted mean vote (PMV) thermal comfort parameter*: a measure by each occupant of their perception to thermal comfort varying from –3 for too cold to 0 for neutral and +3 for too hot.
- *Pressure test*: a method for testing the airtightness of a building or a component such as ductwork.
- *Recirculation*: the blending of fresh air with extract air for recycling back into a ventilated space. This forms an important part of an air-driven heating or cooling system.
- *Specific fan power*: the electrical energy used to drive each litre/second of air through a ventilation system (measured in watts per l·s<sup>-1</sup>).
- *Task ventilation*: a system by which fresh air is ducted directly to the point of need.
- *Ventilation effectiveness*: a term used to describe the degree that fresh air is mixed in a space (see section 2.4.7.5).

## 2.1.4 Energy and carbon considerations

Many countries are committed to significantly reducing carbon emissions with the aim of achieving carbon neutrality. There is also strong demand to improve the energy performance of existing buildings. Within Europe, energy conservation requirements for buildings are covered by the Energy Performance of Buildings Directive (EU, 2010). This requires member states to apply minimum requirements covering the energy performance of both new and existing buildings. There is currently a commitment to achieving carbon-neutral buildings by 2020. In the UK, the Government has also introduced a Climate Change Levy (HMRC, 2012), effectively a specific tax on energy use. To encourage energy efficiency it has also introduced an enhanced capital allowance scheme for certain energy-efficient measures (Carbon Trust, 2012). It is intended that these measures will stimulate a greater interest in energy efficiency amongst building owners and operators and that energy efficiency will be given a greater prominence in decisions about building design. Allied to this has been the introduction of revised Part L of the Building Regulations in England as well as revisions to Welsh and Scottish Regulations. Similarly, more demanding energy-efficiency requirements for buildings are being introduced into the regulations of many other countries. These set significantly more challenging targets for energy-conservation aspects of buildings than has hitherto been the case. The combined effect of these regulatory measures is expected to be a significant improvement in energy performance, certainly in new buildings and those undergoing major refurbishment.

As insulation and construction techniques steadily improve, ventilation losses account for an ever-greater proportion of the total building energy consumption. Therefore, there is much emphasis on improving building airtightness and regulating the rate of ventilation. However, these need to take place in conjunction with providing sufficient ventilation for air quality. Fan systems must also be energy efficient to ensure that mechanical systems operate at optimum efficiency. Part L of the Building Regulations for England and Wales (NBS, 2013a) therefore imposes requirements on airtightness performance and on the overall specific fan power of a system (see section 2.3.5.2). Where thermal ventilation losses are significant, increasing use is being made of ventilation heat recovery systems. In some instances these form a major component in reducing energy consumption and, in some countries are compulsory for some building types.

A further method for improving energy efficiency is to allow indoor temperature to drift in response to adaptation to climate conditions. Again, ventilation can play an important role by offering a degree of passive cooling and air movement.

## 2.1.5 System costing

System costing is inevitably a major consideration, especially in relation to payback periods and overall strategic benefit of carbon and energy reduction. Basic guidance is included in CIBSE TM30: *Improved life cycle performance of mechanical ventilation systems* (2002) and BSRIA *Rules of Thumb* (5th edition) (2011).

## 2.2 Design criteria

### 2.2.1 Introduction

The selection of a ventilation strategy is affected by location, plan depth, heat gains, internal and external pollutant sources, economics, energy and environmental concerns and internal layout. Ultimately it is the use and occupancy of a space that determines the ventilation needs. There is no universal economic solution, although there are some best practice indicators. It is essential that the client understands and accepts the ramifications of the selected strategy. Full details on the operational performance and selection of individual systems are covered in section 2.3. In selecting an appropriate ventilation strategy thought must be given to meeting the requirements of the people and processes that occupy the building without being excessive and therefore wasteful. However, the pursuance of an integrated design approach to achieve this also links the ventilation strategy with the design of the building fabric in that, as a prerequisite, all reasonable steps should be taken to maximise the potential of the fabric.

The design process must be based on a clear understanding of client and end-user needs and expectations and must be followed by effective commissioning, handover and building management. Close collaboration between the architect, services and structural engineers and the client is essential from the earliest stages of the outline design process. In each case, initial agreement should be reached on the needs required. Checks should be carried out continuously by the design team to ensure that the implications of any changes made during design, construction or subsequent fit-out are understood and mutually acceptable.

This section considers basic design criteria. More specific information about ventilation techniques and components are given in subsequent sections.

**Table 2.1** Purposes of ventilation

Purpose	Explanation
To provide sufficient 'background' ventilation for occupants in terms of air quality for breathing and odour control	Typical rates need to be increased where smoking is permitted or additional sources of pollution are present. Most pollutants originate from sources other than people but in such cases general ventilation has been shown to be much less effective than treating the problems at source: e.g. by specification, cleanliness and local extraction.
To provide natural cooling during the occupied period	Care must be taken to avoid excessive air change rates that may cause draughts or disturb documents. Higher rates may be practicable in spaces occupied transitionally, such as atria. The balance point above which mechanical cooling will provide a more effective solution should be considered.
To provide natural cooling outside the normal occupied period	Night cooling or 'night purging' can remove heat built up in a structure and its contents and provide some pre-cooling for the following day. Practical limitations will exist in terms of acceptable secure openable areas in the case of natural ventilation and on duct size and fan energy consumption for ducted mechanical systems.
To exhaust heat and/or pollutants from localised sources or areas	Examples are kitchens, toilets, vending areas and equipment rooms. This enables adjacent areas to be more comfortable, with less conditioning of the air. Such systems often need to operate for longer hours than those serving the main spaces, therefore independent extract systems are preferred.
To act as a carrier mechanism for mechanical cooling and/or humidity control	This can be either via an all-air system in which the air is treated centrally or via air/water or unitary systems in which the air is recirculated and treated locally.
To prevent condensation within the building fabric	Adequate ventilation for condensation control exceeds the minimum rate of fresh air necessary for health and comfort. There is a specific need to address the ventilation of areas where moisture-generating activities occur.
To enable the efficient operation of processes	Needs are entirely dependent on the process. Ventilation may be required to ensure safe combustion or to ensure that machinery is maintained within a suitable temperature range, e.g. lift motor rooms.

#### 2.2.1.1 Purpose of ventilation systems

In designing any ventilation system it is necessary to understand the functions required of it. These are summarised in Table 2.1.

During periods of heating or active cooling, any fresh air ventilation above that needed to control air quality has an energy penalty. During summer, in non-air-conditioned spaces, ventilation rates above those required for air quality may reduce the demand for mechanical cooling, although this will only be possible when the outside air temperature is lower than the room temperature. Even if inside and outside temperatures are similar, increased air movement can improve comfort as described in CIBSE Guide A, chapter 1 (2015a).

#### 2.2.1.2 Occupancy performance

There is much evidence showing that the effectiveness of building ventilation has a significant effect on the performance of those working in the building. Poor indoor air quality impairs the performance of employees in a workspace (Andersson *et al.*, 2006). It has also been shown to result in poor health in the home (Bornehag *et al.*, 2005).

Evans *et al.* (1998) have estimated that design, build and operating costs are in the ratio 1:5:200. Therefore, poor standards of building ventilation can have a significant negative effect on operating costs through their adverse effect on employee performance, given that the cost of running and staffing the business is the most significant to users. Over a system life of 10–15 years, a 1 per cent reduction in productivity may easily equal any savings made on the design and installation costs of the system. So it is worthwhile for building owners and operators to ensure that buildings are ventilated to provide a healthy and effective environment.

### 2.2.1.3 Establishing key performance requirements

The key performance requirements that need to be clarified before a ventilation strategy can be selected are summarised in Table 2.2. Ideally, where the issues highlighted in the table have not been covered within the specification documents, the design team should expect to agree requirements with the client at the outset of the project to

optimise the choice of strategy. If the client is unable to advise on the precise needs, they must at least be made aware of any limitations of the chosen design.

The design team should also be able to advise the client of the cost implications of meeting their stated requirements, on a whole-life basis (BSRIA, 2008) if requested. Requirements may be adjusted over the course of the project to meet financial constraints or changing business

**Table 2.2** Establishing performance requirements

Issue	Requirement/comments
Client brief	To be developed in the context of the other issues.
Integrated design	Co-ordinated approach by the architect and other specialists from outline design.
Energy/environmental targets	Use of existing specifications or appropriate advice from the design team required. Compatibility with indoor environment standards.
Indoor environmental standards	Use of existing standards or appropriate advice from the design team required. Areas or objects with special requirements.
Provision of controls	Individual, local, team, zone or centralised basis. Required closeness of control (e.g. of temperature, humidity, air quality, airflow). The required interaction of the end user with the building services. The required basis of control, e.g. temperature, CO <sub>2</sub> , CO or other.
Demands of the building occupants and activities	The business process(es) to be undertaken in the building may demand specified levels of availability of ventilation.  Work patterns over space and over time (regularity, shifts, team structure). Cellular and open-plan mix with associated partitioning strategy and likelihood of change.  Occupancy numbers and anticipated maximum occupancy over the building lifetime that might need to be taken into account.  Average occupancy density and any areas of high or low density.  Functions of space use, processes contained therein and subsequent internal loads (e.g. standard office space, meeting rooms, lecture theatres, photocopying rooms, sports hall, laboratories, manufacturing environments, retail space).  Anticipated diversity of internal loads.
Investment criteria	Constraints imposed by 'letability' requirements.
Value engineering and whole-life costs	Understanding of the client's priorities towards capital cost and issues of whole-life costs. Requirements for calculations to be carried out on systems or system elements and the basis for these calculations. Has the client been involved in discussions of acceptable design risk? The importance of part load performance.
Reliability	The business process(es) to be undertaken in the building may demand specified levels of reliability of the ventilation systems.
Maintenance requirements	Understanding of the client's ability to carry out, or resource, maintenance. Client willingness for maintenance to take place in the occupied space. Any requirement for 'standard' or 'familiar' components.
Associated systems	Implications of any particular requirements, e.g. fire, security, lighting, acoustic consideration.
Security	Restrictions on size and location of any openings.
Future needs	Adaptability, i.e. the identified need to cope with future change of use. Flexibility, i.e. the identified need to cope with future changes in work practices within the current building use. Acceptable design margins: it is important to distinguish, in collaboration with the client, between design that is adequate for current requirements (which may not be currently accepted best practice), design that makes sensible agreed allowances for future changes and over-design.
Aesthetic considerations	The need for system concealment. Restriction on placement of grilles, diffusers etc. Restrictions imposed by local authorities, building listing etc.
Procurement issues	Time constraints. Programming constraints, particularly for refurbishment projects.

**Table 2.3** Issues affecting the choice of ventilation

Issue	Comments	Reference
Location	Adjacent buildings can adversely affect wind patterns. The proximity of external sources of pollution can influence the feasibility of natural ventilation. The proximity of external sources of noise can impact on the feasibility of natural ventilation.	CIBSE AM10 (2005)
Pollution	Local levels of air pollution may limit the opportunity for natural ventilation. It may not be possible to provide air inlets at positions suitable for natural ventilation given the inability to filter the incoming air successfully.	CIBSE TM21 (1999)
Orientation	Buildings with their main façades facing north and south are much easier to protect from excessive solar gain in summer. West façade solar gain is the most difficult to control, as high gains occur late in the day. Low sun angles occurring at certain times of year affect both east and west facing façades.	CIBSE Guide F (2012)
Form	At building depths greater than 15 m the ventilation strategy becomes more complex; the limit for daylighting and single-sided natural ventilation is often taken as 6 m. An atrium can enhance the potential for natural ventilation.	Section 2.3.2.2 CIBSE Guide F (2012)
	Tall buildings can affect the choice of ventilation system due to wind speeds and exposure. Adequate floor-to-ceiling heights are required for displacement ventilation and buoyancy-driven natural ventilation; a minimum floor-to-ceiling height of 2.7 m is recommended.	CIBSE Guide F (2012) Section 2.2.8
Insulation	Insulation located on the external surface de-couples the mass of the structure from the external surface and enables it to stabilise the internal environment. In well-insulated buildings provision must be made for the removal of excess heat, for example through night cooling.	Section 2.4.2
Infiltration	Ventilation strategies, whether natural or mechanically driven, depend on the building fabric being appropriately airtight. This implies a good practice standard of 5 m <sup>3</sup> ·h <sup>-1</sup> per m <sup>2</sup> of façade (excluding consideration of the ground floor) and requires suitable detailing. Site quality checks should be followed by air leakage pressure testing as part of the commissioning requirement.	CIBSE TM23 (2000a) Approved Document B (NBS, 2013f)
Shading	The appropriate use of external planting or other features can reduce solar gain. In terms of effective reduction of solar gain, shading devices can be ranked in order of effectiveness as follows: external (most effective), mid pane, internal (least effective).	CIBSE Guide F (2012)
	Horizontal shading elements are most appropriate for reducing high angle solar gains, for example in summer time on south facing façades. Vertical shading devices are most appropriate for reducing low angle solar gain, e.g. on east and west façades. Control of solar shading devices should be linked with that of the ventilation system. Glare must be controlled to avoid a default to 'blinds-down' and 'lights-on' operation.	CIBSE AM10 (2005)
Window choice	Openable areas must be controllable in both summer and winter, e.g. large openings for still summer days and trickle ventilation for the winter time. Window shape can affect ventilation performance; deep windows can provide better ventilation than shallow. High-level openings provide cross-ventilation; low-level openings provide local ventilation, although draughts should be avoided at working level. The location of the opening areas affects the ability of the window to contribute to night cooling (see section 2.4.2). Window operation must not be affected by the choice of shading device. See section 2.6.9 for details of window characteristics.	CIBSE TM21 (1999a)
Glazing	Total solar heat transmission through window glazing can vary over a sixfold range, depending on the combination of glass and shading mechanisms selected.	CIBSE TM21 (1999a) Baker and Steemers (1994)
	At concept stage the percentage of glazed area (normally 20–40 per cent of façade area) and selection of glazing type must balance thermal, ventilation and lighting needs. The choice includes single, double and triple glazing with selective coatings or gaseous fill. The type of coating may have a greater influence than the glazing type. Ideal glazing is transparent to long-wave radiation and reflective to short-wave radiation. Selective low-emissivity double-glazing is equivalent to air-filled triple-glazing.	
	The use of tinted glazing may increase the use of supplementary electric lighting, increasing internal heat gains and energy use. Window frame construction and detailing must also be considered.	
Thermal mass	Thermal mass is used to reduce peak cooling demands and stabilise internal radiant and air temperatures. The first 50–100 mm of the structure is most effective on a 24-hour basis. Thermal mass can be introduced into the ceiling/floor slab (most effective), walls or partitions, but must be 'accessible' in all cases. Heat transfer can be via the surface of the material or via cores/channels within it. The exposure of thermal mass has architectural and other servicing implications, although these effects can be reduced, e.g. by the use of perforated ceilings. See section 2.4.2.4 for further details of incorporating thermal mass.	

needs. The design team must also be able to advise on the impact of any such changes on building performance.

An appreciation of the issues shown in Table 2.2 is an essential part of the briefing process. Further guidance on briefing as it applies to building services is given in the *Building Services Job Book: A Project Framework for Engineering Services* (BSRIA, 2009a)

#### 2.2.1.4 Interaction with fabric/facilities

##### *Building fabric*

The required ventilation rate is based on fresh air requirements and any additional ventilation required for comfort and cooling purposes. Additional needs for comfort and cooling must take into account:

- internal heat gains generated by the occupants, e.g. occupancy itself, lighting and small power loads such as office equipment, including computers, screens and photocopiers
- solar heat gains
- the thermal properties of the building fabric including insulation, glazing and thermal mass.

Although the architect is associated with making many of the fabric-related decisions, the building services engineer must be able to advise on their implications for ventilation, energy use etc. and must, therefore, be involved in the decision-making process as far as is practical and at as early a stage as possible. The building services engineer should also be consulted prior to any changes that could affect ventilation system performance.

In instances where designs seek to take full advantage of ventilation to maximise natural cooling, the architect and the building services engineer must be able to enter into a dialogue on the issues introduced in Table 2.3, as a minimum. (Note that this table focuses solely on issues relating to the interaction between the building fabric and services. To these must be added, for example, consideration of the building function and broader issues, as raised in Table 2.2.) Where the ventilation strategy for the building depends on its thermal mass (see section 2.4.2.4 and Braham *et al.*, 2001), early consultation with the structural engineer is also needed to consider, for example, the implications for roof design. At some point it may also be necessary to involve a façade specialist, who could advise the client accordingly.

It is important to note that maximising the ‘passive contribution’ to be gained from the building fabric itself requires an understanding of both the advantages and disadvantages of this approach. For example, external shading reduces the need for cooling but increased insulation and airtightness may lead to the need for increased ventilation and cooling.

For a detailed explanation of the role of the building fabric in contributing to an energy-efficient solution, see CIBSE Guide F: *Energy efficiency in buildings* (2012) and other publications cited in Table 2.3.

##### *Airtightness*

It is also important to consider the risks of air leakage through the building fabric and its subsequent impact on infiltration rates and heat loss calculations (see section 2.5.4.4). The most common locations susceptible to air leakage are:

- junctions between the main structural elements
- joints between walling components
- periphery of windows, doors and roof lights
- gaps in membranes, linings and finishes
- service penetrations, e.g. gas and electricity entry points and overflow pipes
- access and emergency openings
- some building materials, e.g. poor quality brickwork, may be permeable.

Airtightness is becoming a mandatory requirement in an increasing number of countries. Full guidance on achieving airtightness is available in Jaggs and Scivyer (2011). In the UK, airtightness requirements are incorporated in Part L of the Building Regulations (NBS, 2013a). The pressurisation test for determining whole-building airtightness is described in ‘Building airtightness’ in section 2.4.7.2. Optimum duct performance is also dependent on effective duct airtightness (see ‘Duct airtightness’ in section 2.4.7.2).

##### *Internal heat gains*

Heat gains impact on the ability of a ventilation system to meet thermal comfort needs efficiently. In the absence of information from the client, the British Council for Offices (BCO, 2009) recommends the following allowances for internal gains when specifying ventilation systems:

- solar gains not to exceed 60–90 W·m<sup>-2</sup> depending upon façade orientation
- occupancy based upon 1 person per 12 m<sup>2</sup>, but diversified wherever possible to 1 person per 14 m<sup>2</sup> at the central plant
- lighting gains of not more than 12 W·m<sup>-2</sup>
- office equipment gains of not more than 15 W·m<sup>-2</sup> when diversified and measured over an area of 1000 m<sup>2</sup> or more, but with an ability to upgrade to 25 W·m<sup>-2</sup>. Local workstation levels are quoted as typically 20–25 W·m<sup>-2</sup>.

##### *Interaction with the lighting system*

The design strategy for daylight provision forms part of the selection process for window and glazing types and shading devices. Integration of the electric lighting system to minimise its impact on the design and operation of the ventilation system requires that internal heat gains from the lighting be minimised by:

- maximising the use of daylighting
- the selection of light levels, differentiating between permanently occupied workspaces and circulation areas (guidance on lighting levels can be found in CIBSE Guide A1 (2015a))

- the selection of efficient light fittings (decorative fittings may have a lower efficiency)
- the installation of an effective lighting control system, relative to time of day and occupancy level
- the use of ventilated light fittings (see section 2.6.4).

Consideration should be given to the impact of the chosen ventilation strategy on the lighting system, for example the use of uplighting with exposed thermal mass (Braham *et al.*, 2001).

### Small power loads

Small power loads, arising from IT and other office-type equipment, are an increasingly significant component of internal heat gains. Accounting for them in the design of the ventilation system requires a realistic calculation of their impact in terms of peak load and anticipated diversity. In order to reduce internal heat gains the designer should:

- encourage the client to select low-energy equipment and introduce power cut-off mechanisms
- locate shared equipment, e.g. vending machines and photocopiers, in a space that can be readily cooled
- where possible separate IT equipment and servers from occupied spaces such that the heat from this equipment does not impact on the occupied space.

#### 2.2.1.5 Solar gain

Solar gain primarily occurs through glazing. Short-wave infrared radiation from the sun enters into the space and warms solid surfaces, often making them hot to touch. These then re-radiate into the space at much longer wavelengths that are impermeable to the glass. As a result, the heat becomes trapped causing overheating and indoor air temperatures to rise above the outdoor value. Solar gain is, potentially, a substantial component of excess heat load and can cause serious overheating, especially in a naturally ventilated or non-air-conditioned space. Hence solar gain must be accurately determined and, where necessary, reduced. Mitigation methods include choice of glazing and the use of external shading. While internal shading may reduce glare and the direct impact of radiant heating on a person, it rarely reduces the overall heat gain into a space. This topic is covered in greater detail in CIBSE Guides A (2015a), B1 (2016b) and B3 (2016a).

#### 2.2.1.6 Provision of controls: end-user perspective

The provision of easy-to-use and quick-acting controls is fundamental to occupant comfort satisfaction. Any requirements of the client must be considered in the light of the designer's own experience of end-user behaviour. Control systems are covered in section 2.3.6.

#### 2.2.1.7 Whole-life cost

In the UK it is now a requirement that public sector purchasers move to whole-life cost-based procurement. The UK Private Finance Initiative (PFI) has stimulated a marked increase in interest in whole-life costing and there

has been a growth in the availability of data to support the activity (CIBSE, 2002; BSRIA, 2008).

The proper design of ventilation systems can significantly reduce the whole-life costs. Additionally costly modifications and alterations can be avoided by ensuring that the system requirements are properly defined and the design fully addresses the requirements.

Buildings have to adapt and change in response to business needs. Taking account of this at the design stage can also help to ensure that the system is designed to enable such adaptations to be carried out in the most cost-effective manner, again reducing the whole-life costs of the system.

## 2.2.2 Contaminant control

A fundamental role of ventilation is contaminant control. It is important therefore to understand the characteristics and significance of key pollutants and pollutant sources. Indoor pollutants are derived from both outdoor and indoor sources and each of these sources imposes different requirements on the ventilation control strategies needed to secure good health and comfort conditions. This topic is covered in more detail in sections 1.7 and 8.4 of CIBSE Guide A: *Environmental design* (2015a).

### 2.2.2.1 Outdoor air pollution

Clean outdoor air is essential for achieving good indoor air quality. Although air cleaning by filtration is possible, it is costly and not appropriate in the many buildings that are naturally ventilated, leaky or ventilated by mechanical extract systems. Also, general filtration is less effective at controlling respirable fine particulates (e.g. at less than  $2.5\ \mu\text{m}$ ) and gaseous pollutants. Filtration is covered in more detail in section 2.3.3.

Some air quality problems are global and can only be controlled by international effort. Other pollutants are more regional and may be associated with local industry and traffic. Nature, too, presents its own problems, with large volumes of dust and gaseous emissions being associated with volcanic activity, while naturally occurring radon can penetrate buildings from the underlying geological strata. Even rural areas are not immune to pollution, where the presence of pollen and fungi spores can result in allergic reactions. Typical sources of airborne pollutants are:

- industrial emission
- construction dust
- traffic pollutants
- emissions from buildings (boiler exhausts, cooling towers, etc.)
- rural pollution (pollen, insecticides, etc.)
- soil-borne pollutants (radon, methane, etc.).

Increasing concern about outdoor emissions has resulted in the introduction of emission controls and 'clean air' regulations in many countries. In the US, legislation is covered by the Clean Air Act. In Europe, emissions controls fit within the Air Quality Framework Directive (EC, 2008). Implementation in the UK is set out in the Air Quality Strategy for England, Wales, Scotland and Northern Ireland

(DEFRA, 2007). This report explains the measures being undertaken to reduce pollutant concentration in the air including the designation of Air Quality Management Areas at locations identified as having particularly poor air quality. This is based on the nationwide monitoring of key outdoor pollutants. Building developers must check with local authorities for local air quality conditions and must also provide information on how a proposed development will affect the local air quality. UK guidelines on minimising the risk of pollutant ingress into buildings have been published by BRE (Kukadia and Hall, 2011).

Mitigation within buildings of outdoor pollutant sources is not easy but methods include:

- airtightness to prevent the uncontrolled ingress of outdoor pollutant (see section 2.5.4)
- locating air intakes to avoid outdoor sources (CIBSE, 1999)
- filtration (section 2.3.3)
- temporarily reducing ventilation during transient periods of high pollution (CIBSE, 2015a).

### 2.2.2.2 Indoor pollutants

Pollutants emitted inside buildings are derived from metabolism, the activities of occupants and emissions from materials used in construction and furnishing. Major pollutants include:

- carbon dioxide from metabolism and gas appliances
- carbon monoxide (highly toxic and emitted from poorly maintained gas and other combustion)
- formaldehyde from fibre boards and foam insulation
- moisture (principally generated by occupant activities such as cooking, washing and clothes drying)
- odour (generated as part of metabolism and emitted from furnishings and fabrics)
- ozone (from electrical appliances normally associated with poor maintenance)
- particulates, including dust, organic fragments, fibres and smoke particles
- volatile organic compounds (VOCs) from furnishing fabrics and household chemical products
- laboratory contaminants (chemicals, biohazards, radioactive products).

CIBSE no longer provides recommendations covering ventilation for tobacco smoking. In public buildings in the UK smoking is banned and toxic pollutants generated by smoking are largely regarded as unacceptable, regardless of ventilation rate. Harmful indoor pollutant emissions should always be eliminated where possible. Restrictions on emissions, particularly of VOCs and particles generally apply. More information is given in CIBSE Guide A: *Environmental design* (2015a).

### 2.2.2.3 Exposure limits

Exposure limits for particular airborne pollutants depend upon a range of factors, including the length of exposure

and the general level of health of the person exposed. A detailed discussion is provided in CIBSE TM40: *Health issues in building services* (2006a) and limits for specific pollutants are set out in chapter 8 and Table 1.5 of CIBSE Guide A (2015a).

### 2.2.2.4 Metabolic carbon dioxide

In densely occupied spaces, metabolic carbon dioxide is widely used as a marker for the adequacy of ventilation. Even at quite high concentrations it is generally regarded as a non-toxic gas that, in itself, is unlikely to cause injury except under extremely unusual conditions. However a build-up of CO<sub>2</sub> in a room leads to a feeling of stuffiness and can impair concentration. Elevated levels of CO<sub>2</sub> in the body cause an increase in the rate of respiration. Slightly deeper breathing begins to occur when the atmospheric concentration exceeds 5000 ppm (0.5 per cent by volume). This is the maximum allowable concentration of CO<sub>2</sub> for 8-hour exposures by healthy adults (HSE, 2011). Within the UK, a CO<sub>2</sub> figure of 800–1000 ppm is often used as an indicator that the ventilation rate in a building is adequate. A concentration of 1000 ppm approximately equates to a 'fresh air' ventilation rate of 8 l·s<sup>-1</sup> per person (CIBSE, 2015a). The actual ventilation value depends on the local outside concentration (approximately 350 to 400 ppm outside urban areas) and the level of metabolic activity. Carbon dioxide monitoring for ventilation control is becoming increasingly more common and relatively inexpensive (see section 2.3.6).

## 2.2.3 Fresh air supply rates

### 2.2.3.1 Introduction

Ventilation reduces the concentration of harmful pollutants emitted within a space. It is for this reason that higher ventilation rates are usually associated with improved health. Commonly applied methods for determining suitable outdoor air ventilation rates are:

- a prescriptive method
- a calculation method for the control of a single known pollutant being released at a known rate.

These are briefly described below. More details are provided in section 1.8 of CIBSE Guide A: *Environmental design* (2015a).

### 2.2.3.2 Prescriptive method

In occupied spaces, the fresh air requirement is increasingly specified in terms of flow rate per person. Where ventilation is needed to dilute room pollutants not arising from occupancy, fresh air requirements may be expressed as a volumetric flow rate for the space (e.g. m<sup>3</sup>·s<sup>-1</sup> per m<sup>2</sup>). Formerly, much use was made of expressing ventilation rate in terms of air changes per hour (ACH). This is now falling out of favour because of its high dependency on room volume, which fails to reflect the physical need to provide fresh air or remove heat.

European Standard BS EN 13779: *Ventilation for non-residential buildings. Performance requirements for ventilation and room-conditioning systems* (BSI, 2007a) provides basic definitions of air quality standards in occupied spaces and

**Table 2.4** Ventilation requirements (reproduced from BS EN 13779: 2007 (BSI, 2007a), by permission of the British Standards Institution)

Classification	Indoor air quality standard	Ventilation range (l·s <sup>-1</sup> per person)	Default value (l·s <sup>-1</sup> per person)
IDA1	High	>15	20
IDA2	Medium	10–15	12.5
IDA3	Moderate	6–10	8
IDA4	Low	<6	5

relates these to fresh air ventilation rates required for each occupant (in terms of l·s<sup>-1</sup> per person), using a methodology set out in BS EN 15251: 2007: *Indoor environmental input parameters for design and assessment of energy performance of buildings addressing indoor air quality, thermal environment, lighting and acoustics* (BSI, 2007b). These are summarised in Table 2.4.

It is important to note that these rates relate to comfort air quality and do not necessarily reflect the purity of air with respect to health-related contaminants. They are most applicable for spaces that are relatively free from sources of pollution and for ventilation air that is itself pure.

Building Regulations Part F (NBS, 2013b) require a minimum ventilation rate of 10 l·s<sup>-1</sup> per person for office applications. This fits between classes IDA2 and IDA3 in Table 2.4.

General minimum fresh air requirements for specific building types are given in CIBSE Guide A (2015a).

### 2.2.3.3 Calculating the ventilation rate to control a single pollutant

Where a single known pollutant is emitted at a known rate the required ventilation rate is based on risk assessments, for example in the UK, pollutants under the Control of Substances Hazardous to Health (COSHH) Regulations.

For a single contaminant under steady conditions, the steady dilution equation 2.1 may be applied to determine the flow of outdoor air that, with good mixing, would maintain the contaminant concentration at a specified level.

$$Q = \frac{q(10^6 - C_i)}{(C_i - C_o)} \quad (2.1)$$

where  $Q$  is the outdoor air supply rate (l·s<sup>-1</sup>),  $q$  is the pollutant emission rate (l·s<sup>-1</sup>),  $C_o$  is the concentration of pollutant in the outdoor air (ppm) and  $C_i$  is the limit of concentration of pollutant in the indoor air (ppm). Full details are given in CIBSE Guide A (2015a).

This equation can be adapted for:

- pollutant thresholds quoted in mg·m<sup>-3</sup> and situations where  $C_i$  is small or the incoming air is free of the pollutant in question (see CIBSE Guide A, section 1.8.3.1 (2015a)).
- situations where the ventilation results in a non-uniform concentration so that higher than average concentrations exist in the occupied zone and the

outdoor air supply rate requires to be increased (see CIBSE Guide A, sections 1.8.3.1 and 1.8.4 (2015a)).

- non-steady state conditions that might allow the outdoor air supply rate to be reduced (see CIBSE Guide A, section 1.8.3.2 (2015a)).

A more comprehensive analysis of the relationship between contaminant concentration and ventilation rate is given in BS 5925: 1991: *Code of practice for ventilation principles and designing for natural ventilation* (BSI, 1991).

Note that the existing guidelines for the calculation of outside air ventilation rates are based on the assumptions that the air outside the building is 'fresh' and that the pollutant load is inside the building. For buildings in city areas or adjacent to busy roads the quality of the outside air needs to be assessed, as this can also be a source of pollutants. Where specific problems are anticipated, an air quality survey should be undertaken. This should include measurements at likely times of peak pollution. This is covered in more detail by Kukadia and Hall (2011).

Ventilation should not be used in place of source control to minimise pollutant concentrations in a space.

## 2.2.4 Ventilation for thermal comfort

Ventilation provides an essential means to control thermal comfort. This includes the use of air-conditioning systems for the distribution of heated and chilled air (see CIBSE Guide B3 (2016a)) as well as the use of ventilation to passively cool a space. In the case of natural or passive cooling the ventilation rate required to maintain thermal comfort in a space is often far higher than that needed to meet minimum ventilation rates for air quality. A detailed discussion of the factors that affect thermal comfort is given in chapter 1 of CIBSE Guide A (2015a).

## 2.2.5 Humidity

The role of humidity in maintaining comfortable conditions is discussed in section 1.3.1.3 of CIBSE Guide A (2015a) where an acceptable range of 40–70 per cent relative humidity (RH) is suggested. However, to minimise the risk of mould growth or condensation and maintain comfortable conditions, a maximum design figure of 60 per cent RH is suggested for the design of air-conditioning systems. Within naturally ventilated buildings, humidity levels as low as 30 per cent RH (or lower) may be acceptable for short periods of time. However, low RH can result in unpleasant static electricity shocks, especially when touching metallic objects.

## 2.2.6 Ventilation to avoid interstitial condensation

Many structures are vulnerable to interstitial condensation, which can cause rotting of wood-based components, corrosion of metals and reduction in the performance of thermal insulation. Condensed water can also run or drip back into the building causing staining to internal finishes or damage to fittings and equipment. The traditional view has been that these problems are caused by water vapour generated in the building diffusing into the structure. Avoidance measures have therefore concentrated on the

inclusion of a vapour control layer on the warm side of the structure, appropriate placing of insulation and ventilating the structure to intercept the water vapour before it can condense. In the UK guidance and requirements are given in Part C of the Building Regulations (NBS, 2013c). Ventilation is specifically required in cavities above the insulation in cold pitched and flat roofs, behind the cladding of framed walls and below timber floors. Commonly this is achieved by using natural ventilation openings, which are often required by building codes. Many problems can occur from water entrapped within materials moving within the structure under diurnal temperature cycles. Under these circumstances it is helpful to distinguish between ‘ventilated’ and ‘vented’ air spaces. A ventilated space is designed to ensure a through flow of air, driven by wind or stack pressures, whereas a vented space has openings to the outside air that allow some limited, but not necessarily through, flow of air. As the air in the space expands and contracts under diurnal temperature cycles, water vapour will be ‘breathed’ out of the structure. This mechanism can be very effective in large span structures where it can be very difficult to ensure through ventilation of small cavities.

Detailed design guidance for the provision of ventilation within structures is available in CIBSE Guide A (2015a), BS 5250: 2011: *Code of practice for control of condensation in buildings* (BSI, 2011a) and BRE Report BR 262: *Thermal Insulation: Avoiding Risks* (BRE, 2002).

### 2.2.7 Air movement: limiting air velocities

Excessive air movement creates uncomfortable draughts. Guidelines and standards have been developed to provide guidance on maximum values. Draughts are a particular problem in the vicinity of cold air diffusers and in the presence of uncontrolled cold outdoor air ingress. In warmer weather, the draught caused by air movement can be beneficial and adds to the sensation of cooling. It also reduces the operative temperature on which thermal comfort criteria are largely based. For this reason circulation fans are commonly used to provide comfort in a non-air-conditioned environment. The effect of air movement is function of both mean airspeed and a measure of the fluctuating component, usually turbulence intensity. BS EN ISO 7730 (BSI, 2005a) defines a draught rating (DR) for mechanically ventilated and air-conditioned buildings that combines the effect of velocity, turbulence intensity and air temperature. Discussion of acceptable levels of draught rating and other aspects of air movement is included in CIBSE Guide A, section 1.6.6.5 (2015a).

### 2.2.8 Air distribution

Fresh ventilation air needs to be draught free and maintain a safe level of pollutant concentration in the vicinity of occupants. Important air distribution techniques are used to achieve this, each with a particular purpose. The main approaches are described in the following sections.

#### 2.2.8.1 Mixing (or dilution) ventilation

Mixing ventilation is based on the air being supplied into the room in a manner that creates sufficient turbulence for the contaminants within the space to be equally distributed.

The extraction of air then dilutes the concentration of pollutants within the space. Mixing systems are particularly used with conventional warm air heating and cooling systems since this is able to distribute the thermally conditioned air uniformly. Because the amount of air needed to provide thermal conditioning is usually much greater than that needed to provide fresh air, recirculation is widely used (see section 2.4.3). Mixing system performance is not dependent upon room height or room layout. Air can enter the space via either the floor or the ceiling (see Figure 2.2(a) and (b)). Guidance on diffuser design to create mixing is given in section 2.4.3

#### 2.2.8.2 Displacement ventilation

This is based on the provision of low-velocity air supply that does not mix with the room air. Air is supplied at a low velocity from low-level, wall-mounted or floor-mounted supply air terminal devices directly into the occupied zone, at a temperature slightly cooler than the design room air temperature, see Figure 2.2(c). The air from a wall-mounted terminal flows downward to the floor due to gravity and moves around the room close to the floor, creating a thin layer of cool air. Natural convection from internal heat sources, such as occupants and equipment, causes upward air movement in the room. The warm, contaminated air forms a stratified region above the occupied zone, which is then exhausted at high level. The depth of this layer depends upon the relationship between the incoming airflow and the rate of flow in the plumes. The boundary

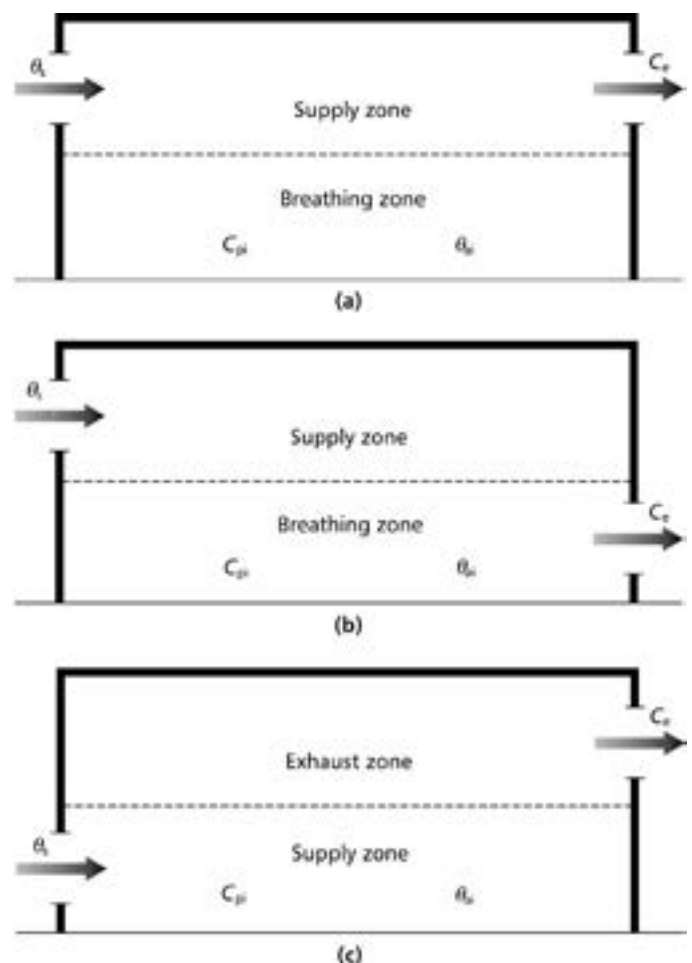

**Figure 2.2** Supply/extract arrangements for ventilation: (a) mixing, supply and exhaust at high level, (b) mixing, supply at high level, exhaust at low level, (c) displacement

will stabilise at a level at which these two flow rates are equal.

The airflow in displacement ventilation has both horizontal and vertical air movement characteristics. Horizontal air movement occurs within the thermally stratified layers that are formed between the upper (warm) and lower (cool) air layers in the room. Vertical air movement is caused by the presence of cold and warm objects in the space. Warm objects, such as people, create upward convection currents; cold objects, such as cold windows and walls, cause downward currents.

For given rates of ventilation and pollutant discharge, the air quality in the occupied zone of a room with displacement ventilation can be higher than that using a mixed-flow ventilation method. In displacement ventilation, air movement above the occupied zone is often mixed and it is when this mixed region extends down into the occupied zone that the air quality becomes similar to that in a mixed-flow system.

There is limited cooling capacity unless it is combined with active cooling systems such as chilled ceilings or beams (see CIBSE Guide B3 (2016a)). Heating must normally be provided using hydronic radiators. In the true meaning of displacement ventilation, natural ventilation is not possible since it cannot provide the precision control that is necessary. Sometimes, however, the definition is loosely applied to the situation where an airflow pattern is established across a building in which fresh air enters through one side and propagates across the building to exhaust openings elsewhere.

With displacement ventilation, a vertical temperature gradient is unavoidable. BS EN ISO 7730 (BSI, 2005a) recommends a vertical temperature gradient for sedentary occupants of less than 3 K. This equates to approximately  $3 \text{ K}\cdot\text{m}^{-1}$  if workers are assumed to be seated, although a limit of 1.8 or  $2 \text{ K}\cdot\text{m}^{-1}$  is often proposed for offices (i.e. 5 K limit for a typical floor-to-ceiling height of 2.5 m). However, as 30–50 per cent of the overall supply-to-extract temperature difference occurs between the supply air and that at ankle level in the main space, a limiting difference between floor and ceiling height for typical office applications can be taken as 7–10 K. The supply air temperature should not be lower than  $18 \text{ }^\circ\text{C}$  for sedentary occupancy and  $16 \text{ }^\circ\text{C}$  for more active occupancy. It is also recommended that the limits of variation of temperature across the room should be within a temperature range of 3 K, i.e.  $\pm 1.5 \text{ K}$  about the mean room air temperature.

A combination of near-floor temperatures below  $22 \text{ }^\circ\text{C}$  and airflows in excess of  $0.15 \text{ m}\cdot\text{s}^{-1}$  may cause discomfort due to cold feet, so occupants should be located a sufficient distance from diffusers. Equipment manufacturers should be consulted for detailed performance characteristics.

The zone around a supply air diffuser within which the supply air conditions have the greatest effect is labelled the near-zone. The permitted near-zone extent together with the maximum allowable comfort temperature at the near-zone perimeter for a given supply air temperature dictates the air volume per diffuser and its size. In an office the near-zone may be 1 m, in a commercial application or in a foyer it may be 3 m. The maximum cooling load that can be delivered by displacement ventilation is therefore limited

to  $25 \text{ W}\cdot\text{m}^{-2}$  due to discomfort considerations (Sandberg and Blomqvist, 1989).

There are conditions under displacement systems that are less effective than traditional mixed-flow ventilation strategies. These include (Jackman, 1990):

- where the supply air is warmer than the room air (except under particular circumstances where cold down-draughts exist over the supply position)
- where contaminants are cold and/or more dense than the surrounding air
- where surface temperatures of heat sources are low, e.g.  $<35 \text{ }^\circ\text{C}$
- where ceiling heights are low, i.e.  $<2.3 \text{ m}$  (the preferred height is not less than 3 m)
- where disturbance to room airflows is unusually strong.

## 2.2.9 Noise

Noise is generated by mechanical systems or can enter into the building from outside sources. Naturally ventilated buildings can be particularly prone to outside noise through open windows while mechanically ventilated buildings can be prone to system noise. Guidance on maximum noise thresholds are given in chapter 1 of CIBSE Guide A (2015a). Noise is considered in more detail in section 2.5.2 and CIBSE Guide B4 (2016c).

Solutions to minimising noise include the following.

- Naturally ventilated buildings:
  - acoustic vents
  - noise barriers (vegetation and fences)
  - location of intakes away from noise zones; reduced noise locations can include high-level intakes (e.g. by using wind towers), courtyards and at locations away from busy roads.
- Mechanically ventilated buildings:
  - control of external noise sources
  - limitations on mechanical duct flow velocity
  - use of silencers.

## 2.3 Systems

### 2.3.1 Introduction

A wide range of ventilation systems and associated technologies is needed to meet the air-quality needs of buildings. Ventilation solutions vary from basic natural ventilation systems to complex mechanical approaches. In addition, the maintenance of air quality may often require air cleaning methods, while energy efficiency demands efficient fans, low-loss systems and good control technology. Providing fresh air to complex spaces also requires the use of duct systems, which must meet the often conflicting requirements of restricted space while providing ducting of sufficient cross-section to minimise pressure losses. This

chapter describes the systems needed to accomplish effective ventilation.

## 2.3.2 Ventilation systems

### 2.3.2.1 Background

The variability of building type and climate conditions results in the need for a wide variety in the type of ventilation system required to maintain good indoor air quality. Within the UK, large city-centre office buildings tend to be mechanically ventilated. On the other hand, many smaller buildings and public buildings, such as schools and hospitals, tend to be predominantly naturally ventilated. Almost all the existing housing stock is naturally ventilated, although modern airtight housing is increasingly being fitted with mechanical systems incorporating heat recovery (see section 2.3.4). Demand for improved thermal comfort, combined with large internal heat gains, is resulting in an increasing requirement for mechanically ventilated air-conditioned spaces. In some buildings a combined ‘mixed-mode’ or ‘hybrid’ approach to ventilation is used in which natural ventilation is applied for some of the time or to some of the spaces while mechanical ventilation is used when and where natural ventilation is unsuitable.

### 2.3.2.2 Natural ventilation

Natural ventilation may be defined as ventilation that relies on moving air through a building under the natural forces of wind and buoyancy. A building can be considered to be naturally ventilated when most of the space is ventilated by such forces for most of the period during which ventilation is needed. Some spaces, such as bathrooms, kitchens, WCs and other polluting areas, may be required to incorporate intermittent mechanical extractor fans. Full details on natural ventilation theory and design are given in CIBSE AM10: *Natural ventilation in non-domestic buildings* (2005) (see also section 2.4.2).

In a mild and warming climate, such as the UK, there is still very strong demand for natural ventilation. The Carbon Trust (2007) stated that ‘average overall energy consumption of air conditioned buildings is approximately twice that of similar sized naturally ventilated buildings’. It also stated that ‘making the most of natural ventilation is a simple and cost-effective way of achieving big savings’ (Carbon Trust, 2006). In the case of schools, the UK Commission for Architecture and the Built Environment (CABE, 2009) requires that natural ventilation be used wherever possible. Similarly, the carbon reduction strategy of the UK National Health Service (NHS, 2009) states that ‘Buildings designed with passive ventilation have improved resilience to energy supply failure and are more energy efficient than mechanically ventilated buildings. In an acute hospital up to 70 per cent of net floor space could be entirely or partially naturally ventilated.’ However, natural ventilation may not always be the best choice and it is important that the economic benefits are properly assessed and compared with alternative solutions.

Typical natural ventilation configurations are summarised in Figure 2.3. Purpose-provided ventilation openings can consist of a combination of vents, stacks, wind towers and openable windows. Traditionally, the provision of an

openable area equivalent to 5 per cent of floor area has been regarded as a satisfactory default minimum for fulfilling occupant ventilation needs and general purging by natural ventilation. This, however, does not necessarily satisfy requirements for special air quality needs or satisfy all the requirements needed for natural summer cooling.

A prerequisite for the use of natural ventilation to provide cooling for thermal comfort is the control of heat gains into the occupied space. Natural ventilation cannot provide a constant flow rate but the important parameter is the time-averaged flow, rather than the instantaneous flow rate. This means that, within reason, the fresh air rate can vary without there being any significant variation in indoor air quality because of the fresh air quality reservoir provided by the volume of the space.

#### *Wind-driven natural ventilation*

Wind pressure acting on a building drives airflow through windows, natural vents or mechanically controlled openings, as well as through adventitious leakage openings in the building fabric. Wind-driven ventilation is caused by varying surface pressures acting across the external building envelope see (Figure 2.4). The distribution of pressure depends on:

- the terrain
- localised obstructions
- the wind speed and its direction relative to the building
- the shape of the building.

Air will flow through the building from areas of high pressure to areas of low pressure. In very general terms, building surfaces facing into the wind will experience positive pressures; leeward surfaces and those at right angles to the wind direction will experience negative pressure (suction). Since wind velocity increases with height and the wind pressure increases as the square of wind speed, the top of high-rise buildings can therefore experience relatively large wind pressures compared with ground level.

By locating openings in the positive and negative pressure regions, a suitable flow pattern through the building can be planned. Knowledge of local climate conditions is essential. Suitable openings include windows vents and wind towers (see section 2.6.9).

#### *Stack or buoyancy-driven ventilation*

Stack-driven ventilation is driven by the pressure differences created between the inside and outside of a building by temperature difference (see chapter 4 of CIBSE Guide A (CIBSE, 2015a)). Warm air inside a space rises to be replaced by colder air, as shown in Figure 2.5. In the normal situation, where the inside of the building is warmer than outside, the pressure difference acts inwards at the lower levels of the building and outwards at the high levels. The driving pressures created by stack effect can often be similar in magnitude to wind-driven ventilation pressure, especially in sheltered locations. Stack ventilation is therefore an important contributor to natural ventilation design. Systems can be applied to both single-storey and multi-storey buildings by utilising interconnected openings

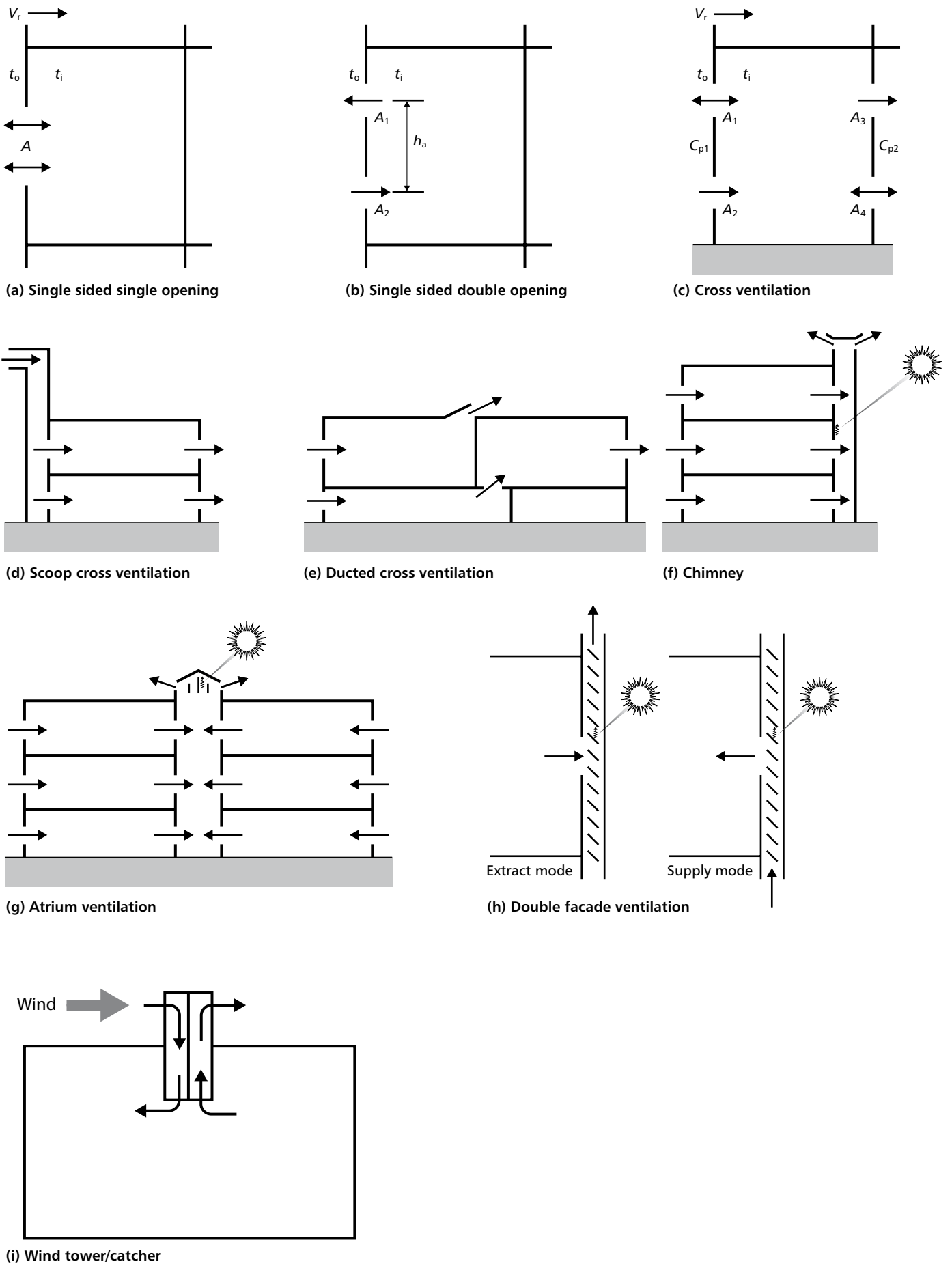

This publication is supplied by CIBSE for the sole use of the person making the download. The content remains the copyright of CIBSE.

Figure 2.3 Typical natural ventilation configurations

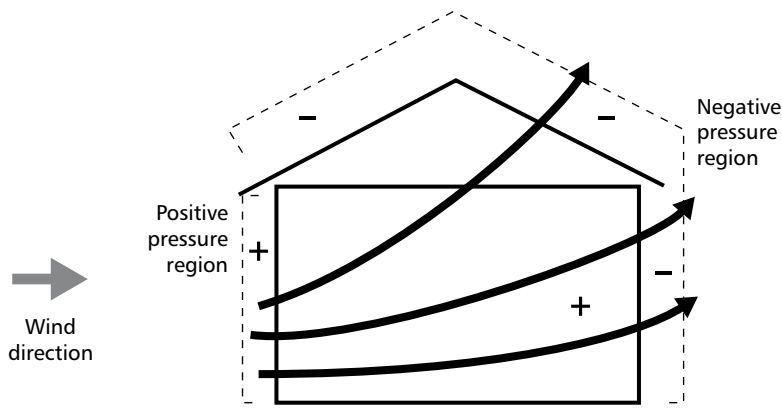

**Figure 2.4** Wind-driven ventilation (from *Guide to Ventilation* (AIVC, 1996) reproduced by kind permission of AIVC)

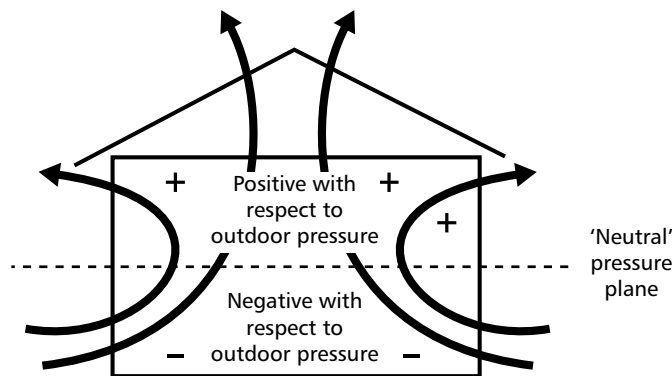

**Figure 2.5** Stack-driven ventilation. Flow pattern for outside temperature less than inside temperature (from *Guide to Ventilation* (AIVC, 1996), reproduced by kind permission of AIVC)

placed at different heights. Design details are covered in section 2.4.2.

Stack-driven ventilation is enhanced by maximising the vertical distances between openings. This may be accomplished by atrium design (see ‘Atrium ventilation’ in section 2.3.2.2) or by the use of passive stacks (see section 2.6.9.12).

*Combined wind and stack-driven ventilation*

Combined wind and stack systems can provide ventilation irrespective of driving force. Good designs of natural ventilation should seek to utilise both forces. This is accomplished by optimising the location of openings to benefit from wind effect and temperature difference. In particular wind pressure can enhance stack effect by placing stack outlets in the negative pressure region above the roof (see ‘Wind-driven natural ventilation’ in section 2.3.2.2). An example of the interaction of wind and stack pressure is given in Figure 2.6.

*Atrium ventilation*

An atrium is a variation on the chimney ventilation principle (see Figure 2.7) The essential difference is that the atrium serves more functions than the chimney; for example it can also provide space for circulation and social interaction. These can restrict the flexibility to locate the atrium to maximum advantage for ventilation purposes. The design of atria is discussed in detail by Saxon (1986).

With a centrally located atrium, the air can be drawn from both sides of the building, thereby doubling the plan width

of the building that can be ventilated by natural means (see ‘Cross-flow ventilation: maximum penetration depth’ in section 2.3.2.2). Note that the same effect could be achieved by a central spine of chimneys and wind terminals.

The atrium also provides an opportunity for introducing daylight into the centre of a deep-plan building. Because atria are designed to capture natural light, they are by definition solar assisted. To promote natural ventilation, the air temperature in the atrium should be as high as possible over as great a proportion of the atrium height as possible. If the atrium is open to the surrounding space, or if it provides high-level walkways between floors, then excess temperatures at occupied high levels may be unacceptable. The design should therefore seek to allow solar energy to be absorbed by surfaces such as:

- elements of the structure
- solar baffles or blinds that act as shading devices.

As stack ventilation, roof vents must be carefully positioned within the form of the roof so that positive wind pressures do not act on the outlets thereby causing reverse flow. This is achieved by:

- designing the roof profile so that the opening is in a negative pressure zone for all wind angles
- using multiple vents that are automatically controlled to close on the windward side and open on the leeward side
- using dampers on the outlets to control the air path in high winds

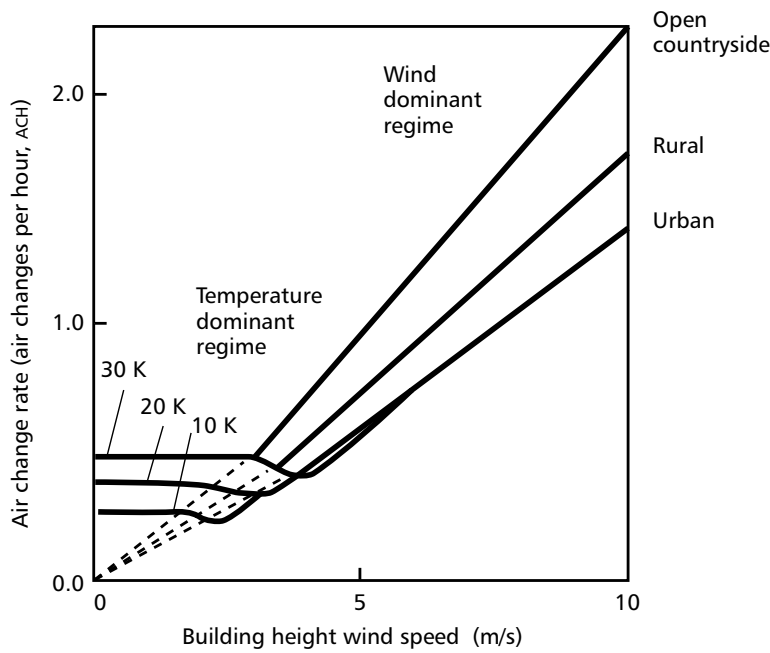

**Figure 2.6** Combined effect of wind and temperature difference on ventilation rate and airflow pattern (from *Guide to Ventilation* (AIVC, 1996) reproduced by kind permission of AIVC)

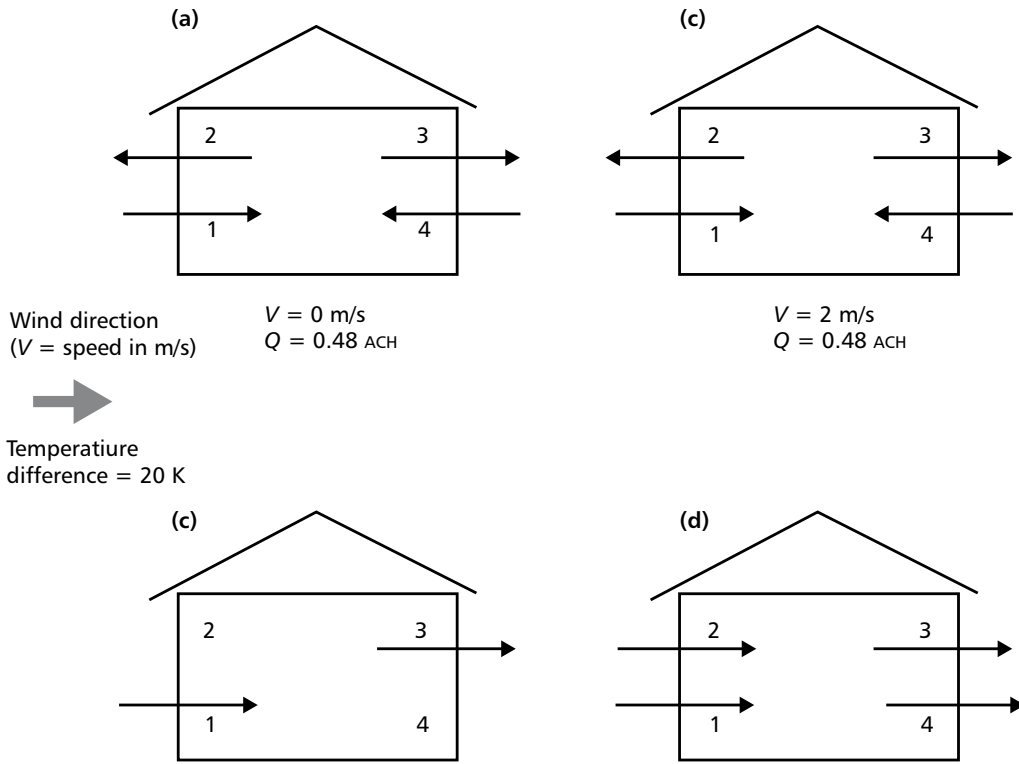

**Notes**

While the rate of ventilation can be held almost constant for a range of weather conditions, the pattern of airflow changes.

In (a), ventilation is dominated by temperature (temperature dominant regime). Air enters through the lower openings (1 and 4) and leaves through the upper openings (2 and 3).

As wind increases in situation (b), wind pressure reinforces stack pressure at the windward lower opening (1) and leeward upper opening (3), while opposing the stack pressure at the other openings (2 and 4). Although the pattern and magnitude of flow essentially remains unaltered, the flow rate through each opening changes.

At (c) the wind exactly opposes stack pressure at openings 2 and 4, leaving flow only through 1 and 3. The effective reduction in the number of openings reduces slightly the overall air change rate. This effect is less pronounced as the number of openings increase since it is unlikely that a significant proportion of them would simultaneously experience exactly opposing pressures.

At greater wind speeds (d), flow enters the building through the windward side (1 and 2) and leaves through the leeward openings (3 and 4). This marks the start of the wind dominant regime.

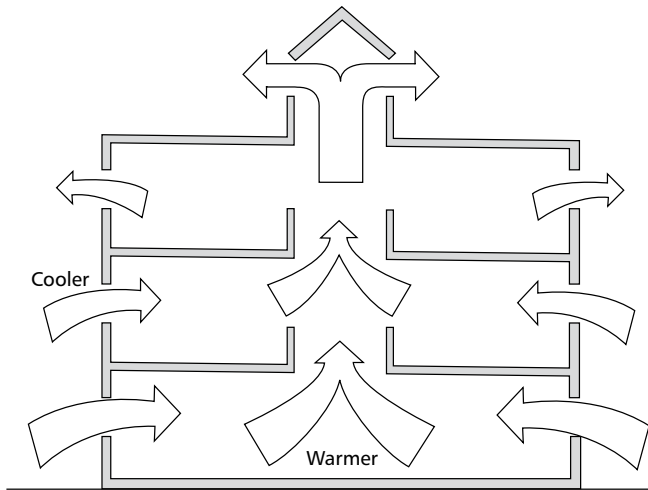

Figure 2.7 Buoyancy-driven ventilation

- using multiple dampers in a controls philosophy to open and close on the windward or leeward side as necessary.

Natural ventilation can be supplemented on hot still days by the use of extract fans in the atrium roof. Subject to approval by the fire officer, these can also form part of the smoke control system. It is likely that any components used in such a system should have fire or smoke classifications (see section 2.5.3).

*Double façade natural ventilation*

The double façade is a special form of solar chimney, where the whole façade acts as an air duct (see Figure 2.8). It can act as an extract plenum similar to a solar chimney. In order to provide absorbing surfaces to promote convective flow in the façade, cavity blinds are used. These also prevent direct solar gain passing through the façade to the occupied space.

Alternatively, the cavity could be used as a supply plenum. Outside air is introduced into the cavity at low level and the cavity acts as a solar collector, pre-heating the outside air.

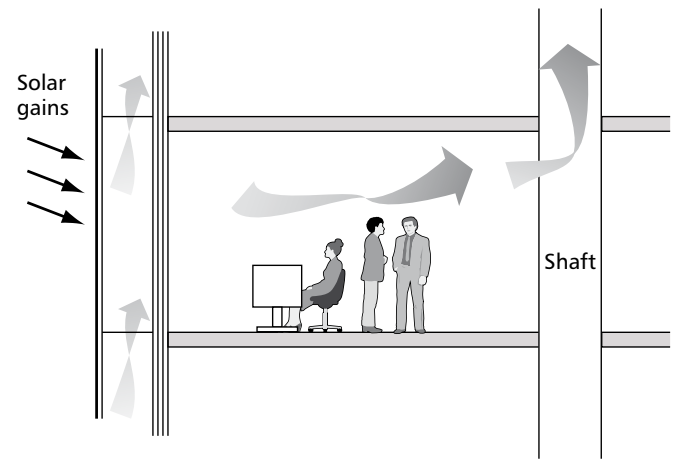

Figure 2.8 Double façade ventilation

The warmed air is then supplied into the occupied zones via ventilation openings between the cavity and the space. If the air in the cavity is too hot, then it can be exhausted to outside or to a heat recovery device.

The efficiency of the solar collector mode can be significantly reduced if the conduction losses are too high. The possibility of condensation should also be checked based on the conditions of the air entering the cavity and the temperature of the glass.

*Single-sided natural ventilation: maximum penetration depth*

Sometimes natural ventilation may only be provided through openings on a single side of a space (e.g. a row of windows, see Figure 2.9). This can restrict the impact of wind-driven ventilation since the same openings must provide for both supply and extract. To ensure that the full depth of a single-sided space is adequately ventilated, the depth of a single-sided ventilated room should not generally exceed 2.5 times the ceiling height (see Table 2.5).

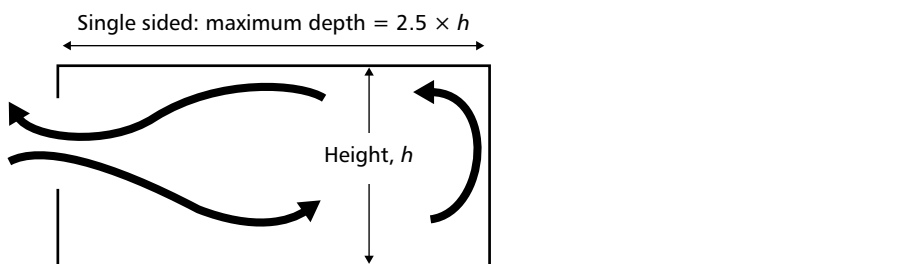

Figure 2.9 Single-sided ventilation maximum penetration (from *Guide to Ventilation* (AIVC, 1996) reproduced by kind permission of AIVC)

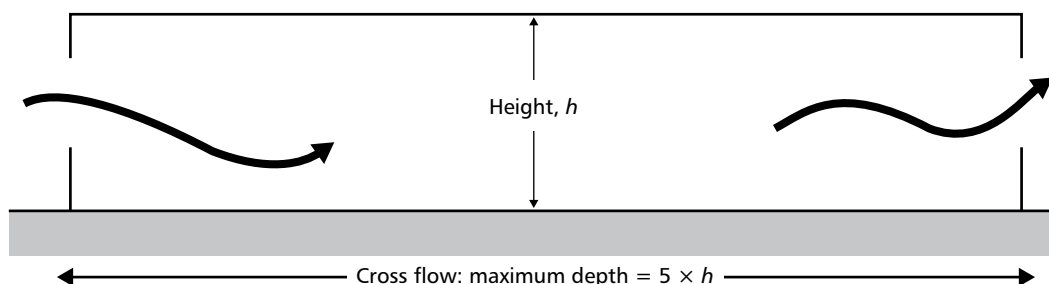

Figure 2.10 Cross-flow ventilation (from *Guide to Ventilation* (AIVC, 1996) reproduced by kind permission of AIVC)

### Cross-flow ventilation: maximum penetration depth

Cross-ventilation occurs where there are ventilation openings on both sides of the space concerned (see Figure 2.10). Depending on weather conditions and the configuration of openings, cross-ventilation can be driven by wind or stack pressure or a combination of both. As the air moves across the zone, there will be an increase in temperature and a reduction in air quality as the air picks up heat and pollutants from the occupied space. Consequently there is a limit on the depth of space that can be effectively cross-ventilated. This implies a narrow plan depth for the building, which has the added benefit of enhancing the potential for natural lighting. Cross-ventilation is only generally effective up to a maximum of five times the floor-to-ceiling height (see Table 2.5).

In the case of an atrium, passive stack or a wind tower it may be possible to extend the building depth to 10 times the ceiling height by creating fresh air cross-flow paths towards or from the centre of the building. More information about natural ventilation components is given in section 2.6.9.

### Advantages and limitations of natural ventilation

Natural ventilation offers many advantages, especially in a mild climate. However, there are also important limitations that can restrict its use, especially in urban environments and where energy efficiency can be improved by heat recovery.

Advantages include the following points:

- It can provide acceptable levels of thermal comfort and indoor air quality under many seasonal conditions and can also meet acoustic requirements for the internal conditions with a minimum use of energy.
- User control: anecdotal evidence suggests that users are reported to favour access to openable windows or some form of local override facility.
- It is relatively inexpensive to install, however costs are heavily influenced by the complexity of window or ventilator design and by the building form necessary to achieve effective natural ventilation.
- Minimal maintenance needs: natural ventilation systems are generally more accessible for cleaning and maintenance than mechanical systems, and there are no components subject to high humidity,

**Table 2.5** Natural ventilation options and maximum recommended depths (from CIBSE AM10: *Natural ventilation in non-domestic buildings* (2005))

Strategy	Maximum effective depth relative to floor-to-ceiling height
Single-sided opening	2.5 × floor-to-ceiling height
Cross flow	5.0 × floor-to-ceiling height
Stack ventilation	5.0 × floor-to-ceiling height
Atria	10 × floor-to-ceiling height if centrally located

such as cooling coils or humidifiers, which can harbour biological growth.

- There is no plant noise.
- It can be integrated with cooling systems to prevent overheating.
- Wind towers, stacks and atria can increase the depth of space that can be naturally ventilated.
- There is no need to house mechanical plant rooms therefore there is more floor space available for occupation.

Limitations include the following points:

- Under-ventilation can occur at low driving forces.
- Inadequate control could lead to excessive winter heat loss. Although close control over temperature and humidity is possible, it requires a tight control strategy. Poor control could lead to inadequate ventilation.
- Risk of draught: poorly located openings could result in cold draughts. Cold back-draught is possible from passive stacks if the air in the stack is not heated to room temperature.
- Restrictions on the maximum penetration depth of natural ventilation could result in limitations on building and/or room size.
- Flexibility is difficult to achieve if extensive partitioning is introduced.
- Overheating risk: natural ventilation may reach its limits if heat gains increase and no mechanical cooling is installed. This limit will depend on many factors including indoor heat gain, solar gains and outdoor temperature. A full thermal analysis is needed to assess the potential of passive cooling. The long-term impact of global warming also needs to be considered.
- Mechanical heat recovery is not possible.
- Predictability: performance can be modelled in theory, but in practice is subject to variation in the motivating forces of wind and weather.
- Noise: there may be problems associated with external noise or the transmission of internal noise.
- Ability to deal with polluted outdoor environments: protection from outdoor pollutants by filtration is not possible but effects of transient pollutants can be mitigated by closing windows and other types of opening during times of pollution (e.g. periods of peak traffic movement).
- Where air is passed from one zone to another the flow of fresh air must be sufficient to provide acceptable air quality in the downstream zone.

### 2.3.2.3 Mechanical ventilation

#### *Mechanical ventilation strategies*

Mechanical ventilation systems incorporate fans and control systems to drive the ventilation process. They are thus able to provide ventilation irrespective of the availability or suitability of natural forces. Large buildings including city centre offices, public buildings and shopping

malls are almost universally mechanically ventilated. In addition to providing fresh air, mechanical systems are also commonly used to distribute thermally conditioned air as part of the building's heating and cooling or air-conditioning system.

The main roles for mechanical ventilation are:

- to provide fresh air ventilation
- to assist in naturally cooling a building when the outside air temperature is less than the indoor air temperature, e.g. night cooling by mechanical ventilation assistance
- to distribute thermally conditioned air from a heating and air-conditioning system.

There are several possible arrangements for the supply and extraction of air in mechanical ventilation systems. These are summarised in Figure 2.11.

*Large building 'balanced' mechanical ventilation*

A schematic of the main elements of a typical large commercial building ventilation system is illustrated in Figure 2.12). This arrangement forms the basis of mechanical systems in large buildings throughout the world and is fundamental to modern heating, ventilation, and air conditioning (HVAC) design. This approach incorporates a separate network of fans and ducts to supply fresh (and often thermally tempered) air to a space and extract polluted air from a space.

Supply air is drawn from the outside via an air intake. This may be pre-heated or cooled by an exhaust air heat recovery unit (see section 2.3.4) before being blended with recirculated air in a mixing box. The air is then filtered and thermally conditioned (heated or cooled) before being supplied to the ventilated space via an air terminal unit and

diffuser. Additional heating or cooling may be applied at the air terminal unit. The characteristics of a diffuser depend on the type of ventilation system. In the case of mixing systems (see section 2.6.4) the diffuser is designed to maximise the level of turbulence and hence encourage the rapid mixing of supply air with room air. The orientation of the flow jets and the flow velocity must be designed such that the heat or cooling characteristics of the supply air is rapidly dispersed into the occupied zone without causing draught or thermal discomfort.

*Displacement systems (see section 2.2.8.2)*

In the case of displacement systems the diffuser must be designed to avoid mixing. Detailed information is given in section 2.4.3.5. Primary thermal treatment may be minimal in the case of a displacement ventilation system. Recirculation is also usually avoided with displacement systems since thermal needs are not provided by the supply air.

*Advantages*

This is a well-established ventilation approach, which has the following advantages:

- It can control indoor climate irrespective of outdoor conditions.
- Control can be provided at an individual level, regardless of location.
- Closeness of control: close control over temperature and humidity is possible (subject to air being at a suitable temperature), but with higher energy use.
- Flexibility: this can be achieved but with cost penalties.
- Predictability: performance can be predicted subject to commissioning and maintenance.

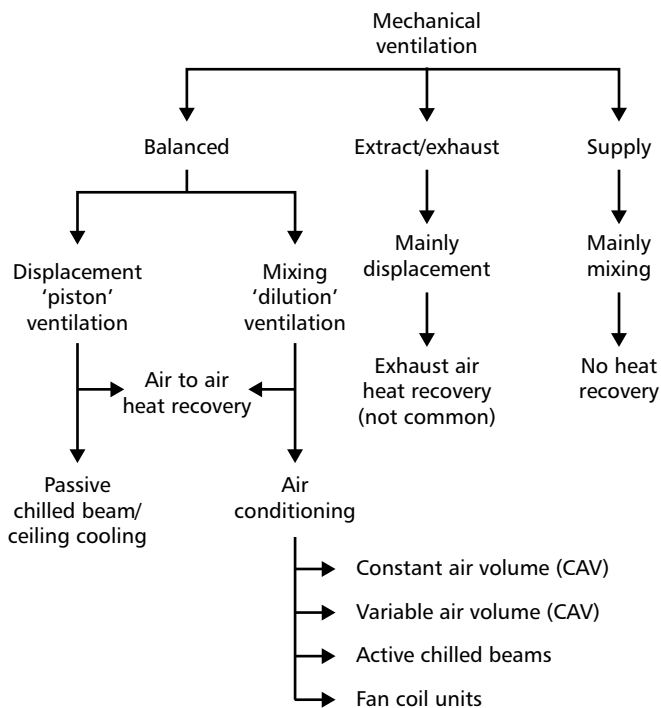

Figure 2.11 Summary of mechanical systems

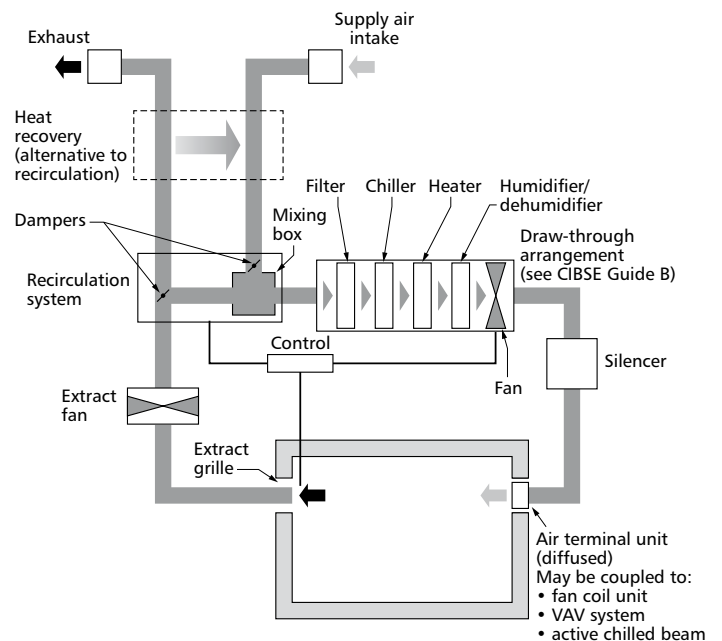

Figure 2.12 Mechanical balanced ventilation for non-residential building (source: Good Practice Guide GPG 257 (Action Energy, 1997) (Crown copyright))

- Ability to deal with polluted environments: there is control of air intake positioning. These should be located away from pollutant sources (see CIBSE, 1999 and BSRIA, 2000). Filtration is possible in harsh environments (see section 2.3.3). However, gaseous and fine particle control may involve considerable expense and regular maintenance.
- It is suitable for hot and cold climates.
- It is suitable for large buildings.
- It is suitable for urban and city centre locations.

### Disadvantages

Disadvantages are as follows.

- *High capital costs:* costs are heavily influenced by the amount of mechanical plant and the need for a dual duct system, i.e. one for supply and one for extract.
- *High running costs:* the system incurs electrical energy demand and regular maintenance costs; power is now limited by regulation (NBS, 2011d/e).
- *Risk of draught from displacement units:* poor design may lead to draught risk.
- *High space demand:* space is needed for ductwork and equipment.
- *Building airtightness:* for the associated heating and cooling system to work at maximum efficiency the building needs to be as airtight as possible.

### Mechanical extract ventilation

In smaller commercial buildings and dwellings, the complexities of balanced systems may be reduced by installation of an extract only system (Figure 2.13). In this case air is extracted from 'wet' or contaminated areas such as process areas, kitchens, toilets and bathrooms.

Clean, make-up fresh air is provided by a network of purpose-provided 'passive' supply openings to occupied zones as well as natural leakage openings. Because air is extracted from the space, the enclosure will be at a negative

pressure relative to the ambient outdoor atmospheric pressure.

When the pressure generated by the mechanical system is greater than the pressures generated by the natural driving forces of wind and stack pressure, the airflow rate is dominated by the mechanical ventilation rate (this process is covered in more detail in CIBSE Guide A (2015a)). Thus this system can inhibit the impact of air infiltration driving forces. However, for full control of ventilation the building should be reasonably airtight.

In the domestic setting, extract ventilation is placed in 'wet' rooms such as WCs, bathrooms and kitchens. The resultant suction pressure prevents moisture, generated in wet spaces, from entering the living area thus reducing the risk of condensation. In addition, cooking fumes and other pollutants are prevented from spreading to occupied zones. In the commercial setting extract ventilation is used for containment. Examples include industrial fume hoods, commercial kitchens and laboratory applications (see CIBSE Guide B0 (2016b)).

A further important advantage of extract ventilation is that contaminants from the exhaust air can be centrally collected and removed by filtration before discharge into the atmosphere. Waste heat can also be extracted using 'run-around' coils for use as supply air pre-heat or, in the case of low-grade heat, for use in conjunction with a heat pump.

Excessive under-pressures will lead to high fan energy consumption and could cause back-draught from flued appliances in adjacent spaces. Hence a full risk assessment will be needed to identify any problem. Part F of the Building Regulations (NBS, 2013b) provides guidance on the avoidance of back-draught when using extract systems.

Fans can be window, ceiling or wall mounted but are most effectively located at a high level away from the source of fresh air such as an internal door or trickle ventilator. In a kitchen they are ideally combined with a cooker hood. Ceiling-mounted fans should be ducted to outside; however, it should be noted that ductwork lengths of as little as 1 m can considerably impair performance due to pressure

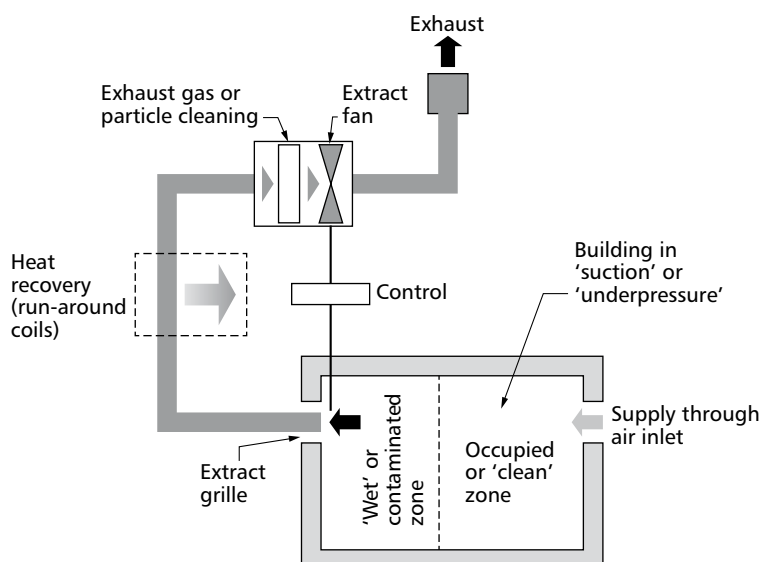

**Figure 2.13** Mechanical extract ventilation system (source: Good Practice Guide GPG 257 (Action Energy, 1997) (Crown copyright))

losses, hence correct selection is imperative. In all cases, manufacturers' data on pressure drop should be applied.

Fans should be located so as not to produce draughts or draw combustion products from open-flue appliances. Guidance is covered in Part J of the Building Regulations (NBS, 2013f), BS 5864: 2010: *Installation in domestic premises of gas-fired ducted-air heaters of rated input not exceeding 70 kW* (BSI, 2010a) and BRE IP 13/94: *Passive Stack Ventilation in Dwellings* (BRE, 1994). Note that cooker hoods require permanently open vents as close as possible to the hood. Control can be by manual switching or through being wired into a door or light switches. Another option is humidity control with manual override, although the sensor may cause the fan to operate when moisture generation is not taking place, for example on warm, humid summer days. The sensor needs to be positioned with consideration to where the major source of moisture is located. It may be more suitable to install cowlled shutters to avoid noise problems with external gravity back-draught shutters rattling in the wind.

When exhaust air is ducted and discharged at a single location, it is possible to recover heat using a run-round coil (see section 2.3.4.3). This recovered heat may be used to pre-heat hot water systems or provide space heating pre-heat by means of a heat pump.

#### Advantages

- It is simple and widely applicable.
- There is a reduced duct demand compared with a combined supply-and-extract system.
- It provides the possibility of rapid extract.
- The system is easily understood.

Heat recovery is possible for secondary purposes using a run-around coil or heat pump to absorb heat from the exhaust air (see section 2.3.4.3).

#### Disadvantages

- The distribution of fresh air supply can be uncertain, depending on the size of the opening area servicing a space and the resistance to flow in the paths leading to the extract system.
- It can be perceived by occupants to have high running costs and is prone to tampering by occupants.
- Noise can be an issue.
- The system requires maintenance.
- Air cleaning not possible.
- Risk of back-draught: resultant under pressure makes this system unsuitable in locations that use open-flue heating appliances.

#### Mechanical supply ventilation

Mechanical supply systems incorporate mechanical fans to supply fresh air to a space (see Figure 2.14). Air is exhausted through purpose-provided passive vents and air infiltration openings. Because air is supplied to the space, the enclosure will be at a positive pressure relative to the ambient outdoor atmospheric pressure.

Mechanical supply ventilation provides fresh air directly to a space. The positive pressure inhibits infiltration ingress from outdoors and adjacent spaces. Additionally, the supply air can be cleaned by filtration (see section 2.3.3) and therefore this method has important applications in clean room design. However, in hot, humid climates, supply ventilation can force moisture-laden outdoor air into the building fabric.

In dwellings the supply fan is typically mounted in the roof space and delivers air that has been filtered and tempered by the roof space into the dwelling. The system works on the principle of continuous dilution, displacement and replacement of air in the dwelling. Air discharge from the dwelling is via purpose-provided extract vents and/or leakage paths. Fans typically run continuously at low speed,

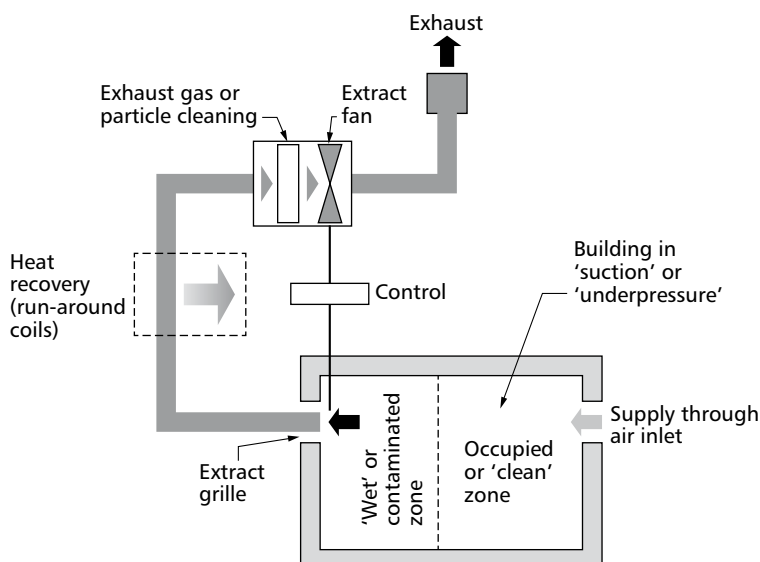

**Figure 2.14** Mechanical supply ventilation (source: Good Practice Guide GPG 257 (Action Energy, 1997) (Crown copyright))

with manual or humidity controlled boost to a higher speed when required. Temperature controls can incorporate single roof space sensors or sensors in both the roof and living spaces. The latter system adjusts the flow rate of the unit to suit the temperatures in both spaces, thereby providing the optimum energy benefits for the occupants. Fan units incorporating highly efficient motor technology can provide a significant net energy gain to the dwelling.

#### Advantages

- It is simple and well established as a means of controlling condensation.
- It is compatible with open-flued appliances.
- It utilises any heat gain in the roof space.
- It allows filtration of the air before it enters the space.

#### Disadvantages

- Occupants perceive the systems to have high running costs.
- Noise can be an issue.
- Systems are prone to tampering by occupants.
- Maintenance (particularly filter replacement) is required.
- Effectiveness depends on building shape/layout.
- Since there will usually be multiple extract vents it is not possible to recover heat or pollutants from the exhaust air

#### Domestic 'balanced' mechanical ventilation system with heat recovery

A scaled-down version of the commercial balanced system is becoming increasingly common in dwellings. A schematic is presented in Figure 2.15.

Almost invariably, the fundamental benefit of a balanced ventilation system is to combine it with an air-to-air heat recovery system (see section 2.3.4).

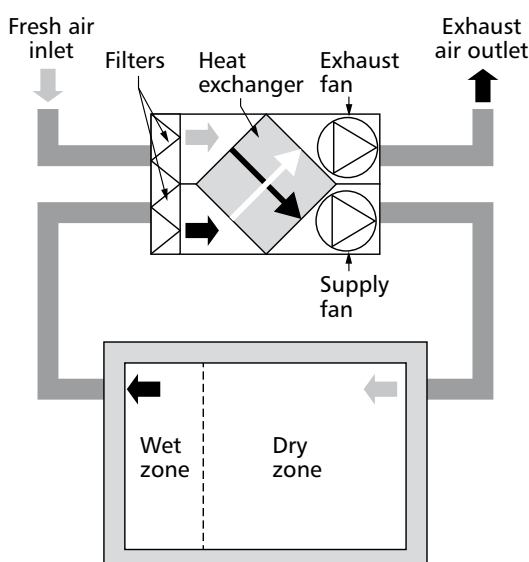

Figure 2.15 Domestic heat recovery system

In operation, warm, moist air is extracted from kitchens, bathrooms, utility rooms and toilets via a system of ducting and passed across a heat exchanger before being exhausted. Fresh incoming air is pre-heated and ducted to the living room and other habitable rooms.

Ducts may be circular or rectangular and typically range in size from 100 to 150 mm in diameter. Air velocities should be kept below  $4 \text{ m}\cdot\text{s}^{-1}$ . Vertical exhaust ducts should be fitted with condensate traps; horizontal exhaust ducts should slope away from fans to prevent condensate running back. Both supply-and-extract grilles should be located at high level as far as practical from internal doors but at a sufficient distance from each other to avoid 'short circuiting', i.e. a minimum of 2 m. Suitable louvres or cowls should be fitted to prevent ingress of rain, birds or insects.

Such systems can provide the ideal ventilation almost independent of weather conditions. During normal operation the total extract airflow rate will be 0.5–0.7 air changes per hour (ACH) based on the whole dwelling volume, less an allowance for background natural infiltration if desired. Individual room air change rates will be significantly higher, possibly 2–5 ACH, in rooms with an extract terminal. To be most effective a good standard of air tightness is required, typically the permeability should be better than  $5 \text{ m}^3\cdot\text{h}^{-1}/\text{m}^2$  at 50 pa. Airflows need to be balanced at the time of installation. Extract rates from bathrooms and kitchens can be boosted during times of high moisture production although care should be taken not to cause draughts. The system can be acoustically treated to reduce noise ingress. Commissioning should follow CIBSE Commissioning Code A: *Air distribution systems* (2006b).

Transfer grilles or clearance beneath internal doors are necessary. Part F of the Building Regulations (NBS, 2013b) requires bottom edges of internal doors to be clear of the floor surface by 10 mm. Transfer grilles are usually positioned not more than 450 mm above the floor. If placed higher they may allow the rapid movement of toxic combustion products or facilitate the spread of fire. Fire dampers should be inserted where the ductwork passes through separating walls and floors, and are desirable in kitchens, for example cooker hoods. In dwellings, the principal requirement is to maintain the separation of fire compartments, for example where ducts pass through protected escape routes. The most common approach is to use a means of preserving the partition, such as intumescent duct sleeves. Dampers should not be used in kitchen extracts, instead protection is required through fire-resisting ductwork (see section 2.3.5).

It is claimed that such systems are effective in reducing condensation due to the controlled ventilation and airtight structure reducing cold air draughts. Manufacturers also claim that they improve indoor air quality and help in controlling dust-mite populations.

#### Advantages

- It provides controlled pre-heated fresh air throughout the house.
- It reduces the heating demand in very airtight dwellings (typically effective in dwellings with infiltration rates  $< 5 \text{ m}^3\cdot\text{h}^{-1}/\text{m}^2$ ).
- It reduces the risk of condensation.

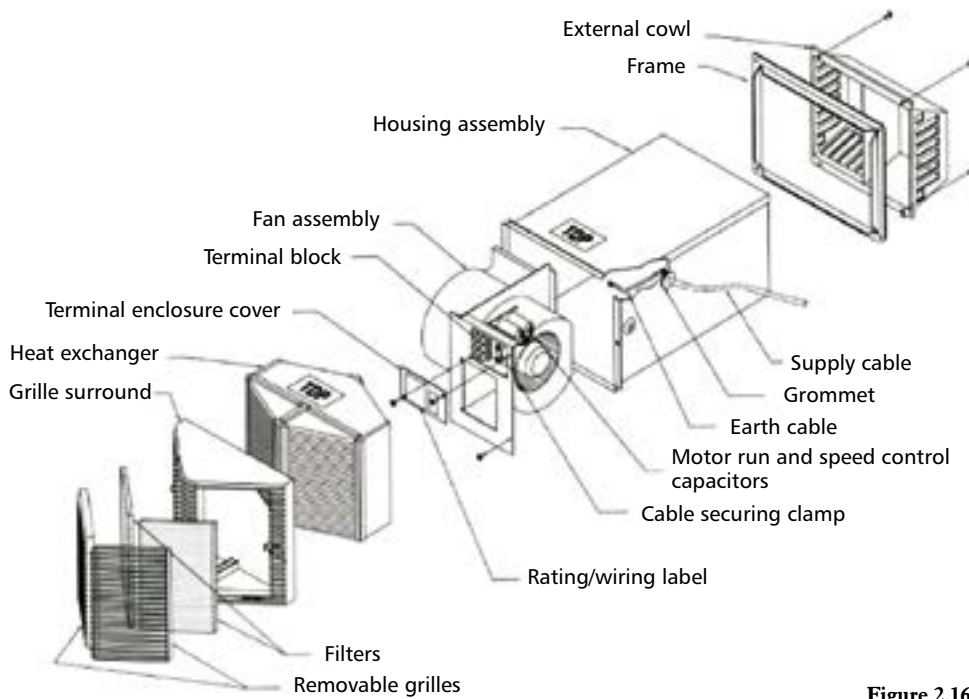

**Figure 2.16** Single-room ventilation heat recovery unit (reproduced courtesy of Vent-Axia)

#### Disadvantages

- Ductwork can be difficult to accommodate.
- Initial costs are high.
- The systems have an ongoing maintenance liability.
- A suitable level of airtightness must be provided.
- Installation and commissioning is more complex than for other systems.
- Because of increased electrical demand to offset fossil fuel heating, a carbon benefit must be demonstrated.
- Systems can freeze and cease to function below 0 °C. Anti-frost measures include switching off, heating or operating at reduced efficiency. All these impact on cost and energy performance.

In cold climates heat recovery systems have become popular for dwellings since considerable energy saving is possible with heat recovery efficiencies of up to 92 per cent being attainable. In milder climates payback periods become more difficult to justify. However, at low temperatures the performance of heat recovery can be hampered by the need for frost protection.

#### Heat recovery room ventilators

This is a single-room version of a mechanical ventilation heat recovery system, which is mounted in an external wall (often to replace an extract fan, see Figure 2.16). These ventilators incorporate a heat exchanger that recovers approximately 60 per cent of the heat from the outgoing air. This is passed across to the incoming air to pre-heat it. The extract fan is often dual speed, providing low-speed, continuous trickle ventilation or high-speed extract. High-speed extract can be under manual or humidity control. This system is principally designed for wet rooms although versions are now available for living and bedrooms.

#### Advantages

- It provides continuous low-level ventilation.
- It provides the option of rapid extract.
- It recovers heat energy.
- It allows filtration of the supply air.
- It is almost silent in operation at trickle speed.

#### Disadvantages:

- Occupants perceive the systems to have high running costs.
- Regular maintenance is required.
- Some recirculation is possible, due to the close proximity of supply-and-extract grilles.
- It is ineffective unless the building is airtight

#### 2.3.2.4 Mixed-mode or hybrid ventilation systems

Mixed-mode ventilation may be defined as the combination of natural and mechanical ventilation and/or cooling systems. These systems are described in full detail in CIBSE AM13: *Mixed mode ventilation* (2000a).

Sub-classifications of mixed-mode systems given in CIBSE AM13 are as follows.

- *Contingency designs*: contingency designs are usually naturally ventilated buildings that have been designed to permit the selective addition of mechanical ventilation and cooling systems where these may be needed at a later date. Occasionally the passive measures may themselves be the contingency plan, with an initially fully air-conditioned building designed to be amenable to subsequent naturally ventilated operation, either in part or in whole.

- *Complementary designs:* natural and mechanical systems are both present and are designed for integrated operation. This is the most common variety of mixed-mode system. Complementary designs can operate in two modes.
  - *Concurrent operation:* the most widely used mode, in which background mechanical ventilation, with or without cooling, operates in parallel with natural systems. Often the mechanical system suffices, controlling draughts and air quality and removing heat, but occupants can open the windows if they so choose.
  - *Changeover operation:* natural and mechanical systems are available and used as alternatives according to need, but they do not necessarily operate at the same time. Changeover may be on the basis of a variety of conditions as suggested below under Control (see section 2.3.6). The chosen control strategy must guard against the risk that changeover systems may default to concurrent operation. Problems of this kind tend to increase with the complexity of the proposed operating strategies.
  - *Zoned systems:* these allow for differing servicing strategies to occur in different parts of the building. The zoned approach works best where the areas are functionally different. Many buildings operate in this manner, e.g. a naturally ventilated office with an air-conditioned computer room and a mechanically ventilated restaurant and kitchen. Mixed-mode increases the range of options available, e.g. offices with openable windows at the perimeter and mechanical ventilation in core areas. The zoned approach works best where the areas are functionally different or where the systems are seamlessly blended.

A selection process for choosing a mixed-mode approach is illustrated in Figure 2.17. The mixed-mode approach should not be seen as a compromise solution. It needs to be chosen at a strategic level and the appropriate option selected. The ability to provide general advice on applicability is limited because the final design can range from almost fully naturally ventilated with a degree of fan assistance for still days, to almost fully air conditioned with the option to revert to natural ventilation at a later date. Selection issues to be considered are listed below.

- *Costs:* capital and operating costs are highly variable. A balancing factor is to what extent supplementary mechanical systems have been installed.
- *Maintenance:* poor designs could result in excessively complex maintenance requirements.
- *Operability:* as above, poor designs in terms of controls complexity can result in inefficient and misunderstood system operation.
- *Window design:* a mixed-mode approach might allow this to be less complicated and more robust than in buildings designed for natural ventilation alone.
- *Energy efficiency:* in relation to fully air-conditioned buildings, mixed-mode systems should use less energy for fans, pumps and cooling. However, this is dependent upon the savings in mechanical plant that have been attained.
- *Occupant satisfaction and comfort:* mixed-mode buildings offer the potential for a high level of occupant satisfaction in that they provide more options for correcting a situation.

**Advantages**

- It can take advantage of natural ventilation to reduce mechanical energy consumption.

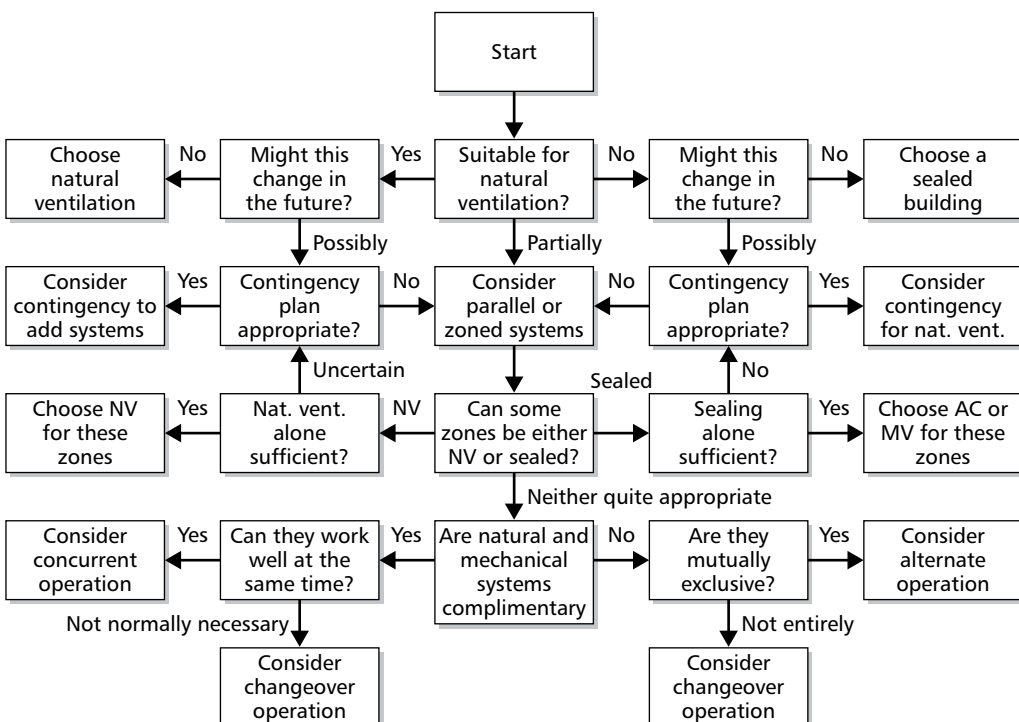

**Figure 2.17** Decision chart for selecting mixed-mode ventilation

- Mechanical components are usually quite basic, hence costs can be lower than a full mechanical system.
- It can be incorporated with mechanical or passive cooling systems.

#### Disadvantages

- It is less controllable than a full mechanical system.
- Complementary systems could be expensive.

### 2.3.3 Filtration systems

In mechanically ventilated buildings, effective air filtration relies on good maintenance (see CIBSE TM26: *Hygienic maintenance of office ventilation ductwork* (2000b)). Poor filtration performance can allow dirt and dust to accumulate within a ductwork system, reducing the efficiency of heat exchange equipment and providing potential sites for microbiological activity. Spores and bacteria can then be released into the occupied space, causing potential comfort and health problems. Natural ventilation systems, on the other hand, are generally more accessible for cleaning and maintenance, and there are no components subject to high humidity, such as cooling coils, or humidifiers, which can harbour biological growth.

#### 2.3.3.1 Nature of airborne contaminants

Atmospheric dust is a complex mixture of solid particulate matter, comprising dusts, smokes, and fumes and non-particulate vapours and gases. A sample of atmospheric dust may contain minute quantities of soot and smoke, minerals such as rock, metal or sand, organic material such as grain, flour, wool, hair, lint and plant fibres and, perhaps, mould spores, bacteria and pollen. Particles are not generally called dust unless they are smaller than  $80\ \mu\text{m}$ .

Smokes are suspensions of fine particles produced by the incomplete combustion of organic substances, such as coal or wood, or by the release into the atmosphere of a wide variety of chemical compounds in a finely divided state. Smoke particles vary considerably in size from about  $0.3\ \mu\text{m}$  downwards. Fumes are solid particles, predominantly smaller than  $1.0\ \mu\text{m}$ , formed by the condensation of vapours.

Non-particulate contaminants consist of vapours condensable at normal pressures and temperatures and gases, of which the most damaging to plants and buildings is sulphur dioxide. Carbon monoxide and various oxides of nitrogen are also present in minute quantities. There is a wide variation in atmospheric solids between rural, suburban and industrial areas, as shown in Table 2.6.

Table 2.7 shows an analysis of a sample of atmospheric dust, in terms of the total numbers of particles for the size range. The figures may be considered typical for average urban and suburban conditions, but wide variations may be encountered in particular cases. Current emphasis in office and other 'standard' accommodation is on the removal of particles smaller than  $10\ \mu\text{m}$ . These, along with chemicals outgassed from carpets and furnishings in modern workspaces, have been linked with reports of sick building syndrome and are able to penetrate into the lungs, causing respiratory problems.

#### 2.3.3.2 Definitions

The following definitions, drawn from BS EN 779: 2012: *Particulate air filters for general ventilation* (BSI, 2012a), are commonly used in describing the properties of air filters.

- *Test airflow rate*: volumetric airflow rate through the filter under test. Expressed in  $\text{m}^3\cdot\text{s}^{-1}$  (for a reference air density of  $1.20\ \text{kg}\cdot\text{m}^{-3}$ ).
- *Face velocity*: the airflow rate divided by the face area ( $\text{m}\cdot\text{s}^{-1}$ ).
- *Initial pressure drop*: the pressure drop (Pa) of the clean filter operating at the test airflow rate.
- *Final pressure drop*: the pressure drop (Pa) up to which the filtration performance is measured for classification purposes.
- *Average efficiency ( $E_m$ )*: weighted average (%) of the efficiency of  $0.4\ \mu\text{m}$  particles for the different specified dust loading levels up to final pressure drop.
- *Average efficiency ( $E_{ij}$ )*: average efficiency (%) for a size range  $i$  at different loading intervals  $j$ .
- *Minimum efficiency*: lowest efficiency among the discharged efficiency, initial efficiency and the lowest efficiency throughout the loading procedure of the test.
- *Initial arrestance (%)*: arrestance of the first 30 g loading dust increment.
- *Average arrestance*: ratio of the total amount of loading dust retained by the filter to the total amount of dust fed up to the final pressure drop.

#### 2.3.3.3 Filter testing

##### Applicable standards

The applicable test standard for particulate air filters for general ventilation is BS EN 779: 2012: *Particulate air filters for general ventilation* (BSI, 2012a).

These filters are classified according to their performance as measured in this test procedure.

In order to obtain results for comparison and classification purposes, particulate air filters are tested against two synthetic aerosols—a fine aerosol for measurement of filtration efficiency as a function of particle size within a particle size range  $0.2\ \mu\text{m}$  to  $3.0\ \mu\text{m}$  and a coarse one for obtaining information about test dust capacity and, in the case of coarse filters, filtration efficiency with respect to coarse loading dust (arrestance).

This European Standard applies to air filters having an initial efficiency of less than 98 per cent with respect to  $0.4\ \mu\text{m}$  particles. Filters should be tested at an airflow rate between  $0.24\ \text{m}^3\cdot\text{s}^{-1}$  ( $850\ \text{m}^3\cdot\text{h}^{-1}$ ) and  $1.5\ \text{m}^3\cdot\text{s}^{-1}$  ( $5400\ \text{m}^3\cdot\text{h}^{-1}$ ).

The performance results obtained in accordance with this standard cannot by themselves be quantitatively applied to predict performance in service with regard to efficiency and lifetime.

For higher efficiencies, BS EN 1822-5: 2009: *High efficiency air filters (EPA, HEPA and ULPA). Determining the efficiency of filter elements* (BSI, 2009a) is applicable.

The BS EN 779: 2012 classification system previously in use (comprising groups F and G filters) has been changed to three groups (F, M and G filters). Filters found to have an average efficiency value of less than 40 per cent of  $0.4\ \mu\text{m}$  particles are allocated to group G and the efficiency reported as '<40%'. The classification of G filters (G1–G4) is based on their average arrestance with the loading dust.

Filters found to have an average efficiency value from 40 per cent to less than 80 per cent of  $0.4\ \mu\text{m}$  particles will be allocated to group M (M5, M6) and the classification is based on their average efficiency ( $0.4\ \mu\text{m}$ ). The filter classes F5 and F6 have changed to M5 and M6, but with same requirements as in the old classification system.

Filters found to have an average efficiency of 80 per cent or more of  $0.4\ \mu\text{m}$  particles will be allocated to group F (F7–F9) and the classification is based on their average efficiency ( $0.4\ \mu\text{m}$ ) as in the old system and the minimum efficiency during the test.

Filters are classified according to their average efficiency or average arrestance under the following test conditions.

- The airflow shall be  $0.944\ \text{m}^3\cdot\text{s}^{-1}$  ( $3400\ \text{m}^3\cdot\text{h}^{-1}$ ) if the manufacturer does not specify any rated airflow rate.
- 250 Pa maximum final test pressure drop for coarse (G) filters.
- 450 Pa maximum final test pressure drop for medium (M) and fine (F) filters.

If the filters are tested at  $0.944\ \text{m}^3\cdot\text{s}^{-1}$  and at maximum final test pressure drops, they are classified according to Table 2.6, for example G3, F7. Filters tested at airflows and final test pressure drops different from those above shall be classified according to Table 2.6, and the classification should be qualified by test conditions in parentheses, e.g. G4 ( $0.7\ \text{m}^3\cdot\text{s}^{-1}$ , 200 Pa), F7 ( $1.25\ \text{m}^3\cdot\text{s}^{-1}$ ).

**Table 2.6** Classification of general ventilation filters

Group	Class	Final test pressure drop / Pa	Average arrestance ( $A_M$ ) of synthetic dust / %	Average efficiency ( $E_M$ ) of $0.4\ \mu\text{m}$ particles / %	Minimum efficiency* of $0.4\ \mu\text{m}$ particles / %
Coarse	G7	250	$50 \leq A_M < 65$	—	—
	G2	250	$65 \leq A_M < 80$	—	—
	G3	250	$80 \leq A_M < 90$	—	—
	G4	250	$90 \leq A_M$	—	—
Medium	M5	450	—	$40 \leq E_M < 60$	—
	M6	450	—	$60 \leq E_M < 80$	—
Fine	F7	450	—	$80 \leq E_M < 90$	35
	F8	450	—	$90 \leq E_M < 95$	55
	F9	450	—	$95 \leq E_M$	70

\* Minimum efficiency is the lowest efficiency among the initial efficiency, discharged efficiency and the lowest efficiency throughout the loading procedure of the test.

### Test for high efficiency filters

The preferred pan-European test method for testing high efficiency EPA (efficient particulate air filter), HEPA (high efficiency particulate air filter) and ULPA (ultra-low particle arrester) filters is BS EN 1822-5: 2009: *High efficiency air filters (EPA, HEPA and ULPA). Determining the efficiency of filter elements* (BSI, 2009a). This test method is based on scanning by a particle counter at the most penetrating particle size (MPPS) of the filter. MPPS is variable and is determined by testing samples of the filter medium used in the manufacture of the filter being tested. The challenge aerosol is di-ethyl-hexyl-sebacat (DEHS) mineral oil or equivalent, but other oils are permitted. Condensation nucleus counters (CNC) are used for monodispersed aerosols and laser particle counters (LPC) for polydispersed aerosols.

The most recent version of the standard introduced a category of EPA grade filters, formally H10 to H12. This was done because the previous classification did not fully represent the test method employed for all the H grades, particularly regarding leak testing. It was decided that the filter grades should be grouped by test method. The grades are now as follows.

- Group E: EPA filters
- Group H: HEPA filters
- Group U: ULPA filters.

Filters are classified in 'groups' and 'classes'. For each group a slightly different test procedure applies. All filters are classified according to their filtration performance.

Group E filters are subdivided in three classes:

- Class E10
- Class E11
- Class E12.

Group H filters are subdivided in two classes:

- Class H13
- Class H14.

Group U filters are subdivided in three classes:

- Class U15

**Table 2.7** Classification of EPA, HEPA and ULPA filters

Filter group/class	Integral value		Local value (see BS EN 1822-4)*	
	Efficiency / %	Penetration / %	Efficiency / %	Penetration / %
E10	≥ 85	≤ 15	Group E filters not leak tested for classification purposes	
E11	≥ 95	≤ 5		
E12	≥ 99.5	≤ 0.5		
H13	≥ 99.95	≤ 0.05	≥ 99.75	≤ 0.25
H14	≥ 99.995	≤ 0.005	≥ 99.975	≤ 0.025
U15	≥ 99.9995	≤ 0.0005	≥ 99.9975	≤ 0.0025
U16	≥ 99.99995	≤ 0.00005	≥ 99.99975	≤ 0.00025
U17	≥ 99.999995	≤ 0.000005	≥ 99.99999	≤ 0.0001

\* Local penetration values lower than those given here may be agreed between the supplier and purchaser.

- Class U16
- Class U17.

After testing, filter elements are classified according to Table 2.7 on the basis of their integral efficiency (Group E) or their integral efficiency and local (Groups H and U) MPPS efficiency or penetration. The other addition is that filters with filter media having an electrostatic charge are classified according to the table on the basis of their discharged efficiency or penetration as per Annex B of BS EN 1822-5: 2009: *High efficiency air filters (EPA, HEPA and ULPA). Determining the efficiency of filter elements* (BSI, 2009a).

#### On-site testing

The efficiency of a filter installation depends not only on the filter efficiency but also on the security of the seal between the filter and the air system. This is particularly vital in HEPA filter installations; hence penetration must be established immediately prior to use and at regular intervals throughout the working life of the system.

A common methodology utilises an oil-based aerosol to challenge the installed filter. Concentrations are determined using photometry:

- DOP (an abbreviation for di-octylphthalates) is an oily liquid with a high boiling point. Normally, DOP vapour is generated at a concentration of  $80 \text{ mg}\cdot\text{m}^{-3}$  and the downstream concentration is determined using a light scattering photometer via a probe that scans the entire downstream face of the filter installation.

#### Gas and vapour removal

Most manufacturers quote efficiencies for removal of a wide range of gases and vapours based on upstream and downstream concentrations. Adsorption filters are also rated in terms of the mass of gas/vapour that can be adsorbed before saturation of the adsorbent.

Specification and testing methods have been developed for gas and vapour removal by filters and recirculating air cleaning units (Gilbert, 1999). This work has looked at the performance of a wide range of systems including active

bonded carbon units and electrostatic filters. Specialist advice should be sought on any requirements.

#### Dry testing

In applications such as cleanrooms used for the production of semi-conductors, testing for local leaks with an oil-based aerosol would result in filter contamination and subsequent production problems. In these circumstances filters are tested using atmospheric air or polystyrene latex spheres (PSL).

#### 2.3.3.4 Filter application and selection

Table 2.8 presents a broad classification of air cleaners and Figure 2.18 illustrates the various characteristics of dusts, mists etc., together with other relevant data.

Table 2.9 provides recommended filter specification data drawn from the National Engineering Specification Y42: *Air Filtration* (NES, 1996) and promoted within BSRIA guidance (Pike, 1996; Bennett, 1996). CIBSE TM26: *Hygienic maintenance of office ventilation ductwork* (2000b) considers other means of reducing the admittance of micro-organisms other than just the installation of a HEPA filter. Under certain conditions, air filters can support the growth of micro-organisms and act as a source of contaminants. Standard air filters can be obtained with an anti-microbial coating that is reported to kill or inhibit the growth of micro-organisms on the filter material and any trapped dust and debris. However, due to the potential for the active biocide to outgas from the surface, the user of such systems should take steps to ensure that they are safe for building occupants. Anti-microbial ductwork coatings are also available, however they also have a potential for the active biocide to outgas from the surface.

Ultraviolet germicidal irradiation (UVGI) is provided by ultraviolet lamps mounted in the supply ductwork. The ultraviolet (UV) light causes inactivation of micro-organisms by disrupting their DNA. This system is claimed to be effective against all types of bacteria and fungi, as well as spores and viruses that are normally found in the air. The user of such systems should ensure that staff are protected from exposure to the UV radiation. Photo-catalytic oxidation technology involves the action of low-energy UV on a catalyst in the presence of water vapour that generates hydroxyl radicals that destroy micro-organisms. As this is

an oxidation process, the microbial hydrocarbons are reduced to carbon dioxide and water. This technique can be used against bacteria, fungi/spores, viruses and allergens.

**2.3.3.5 Filter maintenance**

The life of a filter depends upon the:

- concentration and nature of contaminants
- filter efficiency
- dust-holding capacity corresponding to rise in pressure loss between clean and dirty conditions
- face velocity at the filter.

A maintenance regime can be based on time intervals or on condition. Details of external conditions that may affect filter life, such as the entering pollution concentration, may be determined in consultation with the local environmental health officer. Alternatively, a local survey may be undertaken. Some filter manufacturers provide prediction

data for hours of use for different localities. Tables 2.10 and 2.11 give typical data on the amount and nature of solids in the atmosphere. Issues of external air quality, including sulphur dioxide and particulate matter (PM<sub>10</sub>), are discussed in CM 4548: *Air Quality Strategy for England, Scotland, Wales and Northern Ireland* (DEFRA, 2007), which is subject to periodic review.

If condition-based maintenance is being used, the filter pressure differential should be monitored. Replacement filters are installed when a specific differential is attained. If the filter represents a significant proportion of the total pressure loss of the system, and there is no provision for automatic fan duty adjustment (e.g. a variable air volume (VAV) system), then the rise in pressure loss due to filter soiling should not exceed 20 per cent of the total system loss with a clean filter. This differential can be reported via a building energy management system (BEMS). Note that a method of alerting maintenance staff of filter failure or blockage is also required for the time-based replacement method.

**(a) Dusts, smokes and mists**

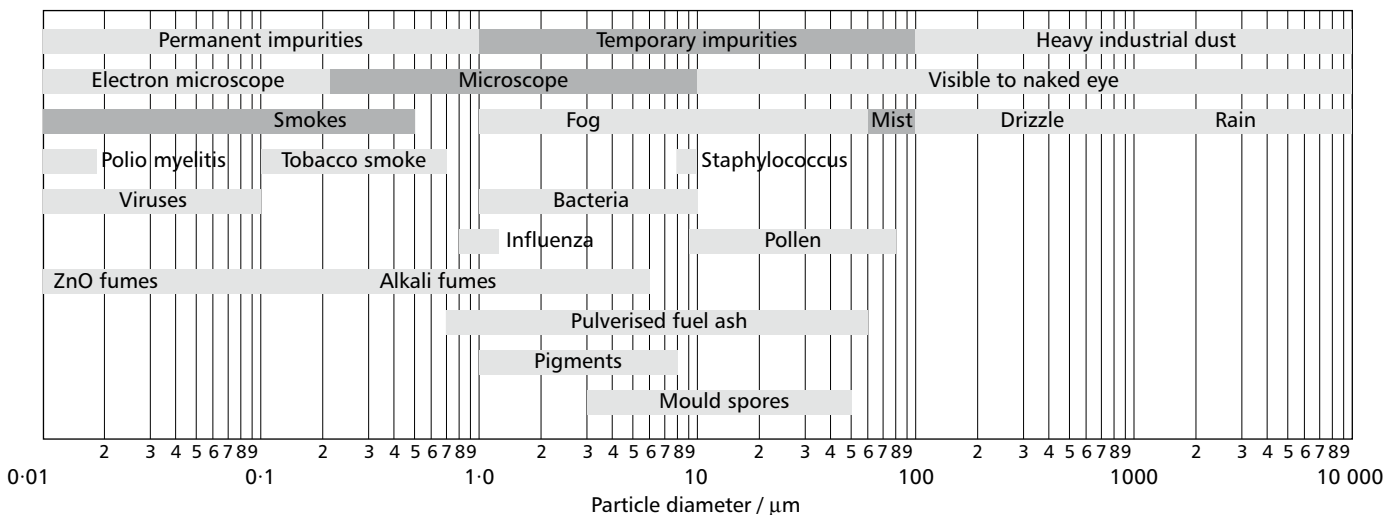

**(b) Dust collectors**

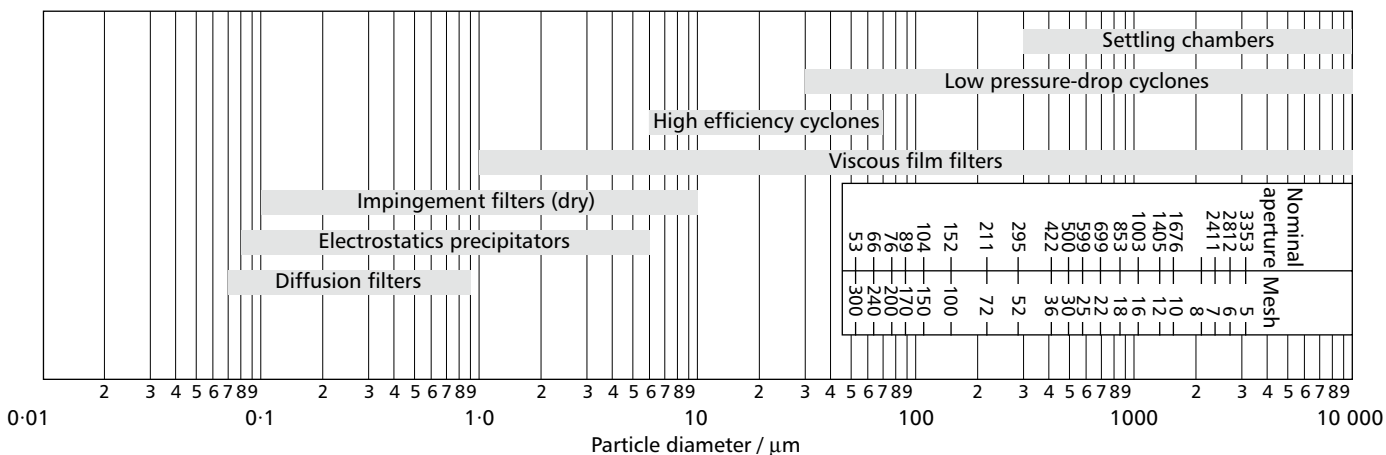

**(c) Settling rates**

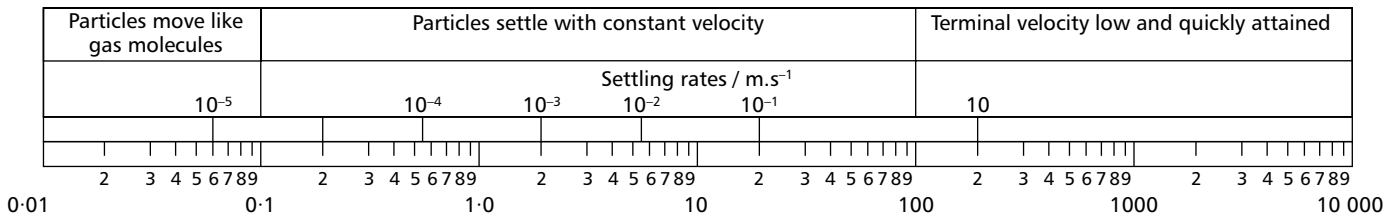

**Figure 2.18** Characteristics of dusts and mists

Table 2.8 Classification of air cleaners

Type	Remarks	Method of cleaning	Face velocity / m·s <sup>-1</sup>	Resistance at face velocity / Pa		Dust holding capacity	Relative efficiency / %		Relative cost
				Initial	Final		Sodium flame	Synthetic dust	
Viscous impingement:									
— panel or unit	Thickness ranges 12–100 mm; small or intermediate air volumes; good for particles > 10 μm diameter; efficiency decreases with dust loadings; used as after-cleaners	Permanent (washable) or disposable	1.5–2.5	20–60 (depending on thickness)	100–150	High; can be critical	10	> 85	Low
— moving curtain	Will handle heavy dust loads; intermediate or large air loads; used as pre-cleaners etc.	Continuous or intermittent; can be automatic	2–2.5	30–60	100–125 (operating)	Self-cleaning by immersion	10	> 85	Medium
Dry:									
— panel, bag, cartridge or unit with fabric or fibrous medium	Small or intermediate air volumes	Usually disposable	1.25–2.5	25–185 (depending on efficiency)	125–250 (depending on efficiency)	Generally not as high as viscous impingement; can be critical	30–80 (depending on filter type, medium and face velocity)	96–100 (depending on filter type, medium and face velocity)	Low to high
— moving curtain	Intermediate or large air volumes	Continuous or intermittent; can be automatic or disposable	2.5	30–60		Self-cleaning	Can be selected over a wide range		Medium to high depending on efficiency
— absolute or diffusion (HEPA)	Pre-filter necessary; small air volumes; particles down to 0.01 μm diam.	Disposable	Up to 2.5	Up to 250		Low	> 99.9	100	High
Electrostatic:									
— charged plate	Pre-filter desirable; after-filter used to collect agglomerates; power-pack and safety precautions necessary (up to 12 kV); particles down to 0.01 μm diam; intermediate to large air volumes	Washable or wipeable; can be automatic	1.5–2.5	Negligible; resistance added (40–60 Pa) to improve uniformity of air distribution	Negligible; resistance added (40–60 Pa) to improve uniformity of air distribution	Can be critical	—	Not suitable over 5 μm diam.	High; low maintenance costs
— charged medium	As for charged plate	Disposable	1.25	25	125	High	55–65	Not suitable over 5 μm diam.	High; low maintenance costs
Adsorption units	Should be protected from dust, oil and grease; used for odour removal*	Can be reactivated	Low	Low; can be selected; constant	Low; can be selected; constant	Medium adsorbs up to half its own weight of many organic substances	95 (dependent on gas to be removed)		High
Mechanical collectors	Not suitable for particles less than 0.01 μm diameter	To be emptied	Varies with design	50–100	Constant (some act as air movers)	High	—	—	High; low maintenance costs

\* Odours can also be removed by combustion, masking or liquid absorption devices

Note: air washers used for humidification or dehumidification purposes sometimes also act as air cleaning devices. These include capillary air washers, wet filters, adsorption spray chambers etc., for which manufacturers' data should be consulted.

**Table 2.9** Recommended filter specification data

Filter data to be specified	Essential	Desirable
Air flow rate ( $\text{m}^3\text{s}^{-1}$ )	*	
Air velocity ( $\text{m}\cdot\text{s}^{-1}$ )		*
Initial filter pressure drop (Pa)	*	
Final filter pressure drop (Pa)	*	
Average arrestance (%)	*	
Initial dust spot efficiency (%)	*	
Average dust spot efficiency (%)	*	
Minimum dust holding capacity (g)	*	
Class of filter (EU number)		*
Size of filter (height, width, limiting depth (mm))	*	
Casing		*
Test standards	*	
Access		*
Filter medium		*

Further details on filter maintenance can be found in guidance produced by BSRIA (Pike, 1996) and BESA (2012). Designers are also referred to CIBSE TM26: *Hygienic maintenance of office ventilation ductwork* (2000b).

### 2.3.3.6 Filter installation

BSRIA has analysed the whole-life performance of filter systems (Pike, 1996; Bennett, 1996) (i.e. the balance between space and capital costs and the operating costs such as inspection, change, energy and costs of associated equipment, e.g. duct cleaning and redecoration). The conclusion is that filter performance depends not only on the filter specification but also on the design and installation of the filter system.

Poor filter installation will neutralise the benefits of specifying good filters. The overall efficiency for the filter installation must be not less than that specified for the filter. It is suggested that:

- air intakes are located at a high level away from the direction of the prevailing wind to prolong filter life and improve the quality of the intake air
- air filters should be protected from direct rain by using weather louvres to prevent waterlogging
- filters should be installed upstream of mechanical equipment to provide protection for that equipment; a final filter should be located downstream of the fan under positive pressure to reduce the risk of dust entering the system downstream of the filter
- adequate access for cleaning should be provided
- filter frames should be of good quality to prevent leakage and distortion; side withdrawal will make this difficult to achieve.

For filters installed in air-handling units (AHUs), and with specific fan power (SFP) in mind, lower filter pressure drops are necessary. Table 2.12 gives maximum 'dirty' conditions.

**Table 2.10** Typical amounts of solids in the atmosphere for various localities

Locality	Total mass of solids / $\text{mg}\cdot\text{m}^{-3}$
Rural and suburban	0.05–0.5
Metropolitan	0.1–1.0
Industrial	0.2–5.0
Factories or work rooms	0.5–10.0

**Table 2.11** Analysis of typical atmospheric dust in relation to particle size

Range of particle size (diameter)/mm	Amount of solid as percentage of number of particles and total mass of particles / %	
	Number of particles	Total mass of particles
30 to 10	0.005	28
10 to 5	0.175	52
5 to 3	0.250	11
3 to 1	1.100	6
1 to 0.5	6.970	2
Less than 0.5	91.500	1

## 2.3.4 Ventilation heat recovery systems

### 2.3.4.1 Background

Heat recovery devices used in ventilation systems generally provide heat recovery from exhaust to supply air in winter and can also recover cooling in peak summer conditions. They are also used in specific system configurations such as indirect evaporative cooling (see CIBSE Guide B, Chapter 3 on air conditioning). Devices used to recover heat from process applications (e.g. dryers, flues) may transfer the heat to the process or to another application. Selection of equipment should be suitable for process exhaust temperatures. Where the recovered heat is fed to a ventilation system, modulation control is normally required to prevent overheating in warm weather.

Buildings should be airtight, as infiltration has a significant impact on the viability of heat recovery (AIVC, 1994).

Technical considerations for design and selection of heat recovery devices include:

- heat recovery efficiency (sensible and total)
- airflow arrangement

**Table 2.12** Maximum final pressure drops for filters (reproduced from Table 9 of BS EN 13053 (BSI, 2006c), by permission of the British Standards Institution)

Filter class	Final pressure drop / Pa
G1–G4	150
F5–F7	200
F8–F9	300

The final pressure drops are the typical maximum values for AHUs in operation and lower than those used in BS EN 779: 2012 (BSI, 2012a) for classification purposes, for reasons of energy saving, and the performance obtained from tests according to BS EN 779 are not necessarily met at these lower pressure drops.

- fouling (filters should be placed in both supply and exhaust airstreams)
- corrosion (particularly in process applications)
- cross-leakage
- condensation and freeze-up
- pressure drop
- face velocity
- construction materials (suitability for temperatures, pressures, contaminants)
- maintenance (in particular cleaning of surfaces)
- controls.

#### 2.3.4.2 Efficiency analysis

The heat recovery efficiency (or effectiveness) of a device is normally defined as follows:

$$\text{Efficiency} = \frac{\text{Actual heat transfer}}{\text{Maximum possible heat transfer}}$$

The maximum theoretical efficiency is a function of the exchanger flow configuration; counter-flow exchangers have a higher theoretical efficiency than parallel flow exchangers. Practical considerations often favour cross-arrangements that lie between the two (ASHRAE, 2008).

Sensible heat recovery devices do not transfer moisture. Latent heat is only transferred when the warmer airstream is cooled below its dew-point and condenses. Total heat recovery devices transfer both sensible heat and moisture between the airstreams. Moisture transfer is desirable in hot, humid climates to reduce the moisture in the supply air and in cold, dry climates to raise the moisture in the supply air.

Drains should be included to collect and dispose of the condensate. In extreme conditions, where the temperature also drops below 0 °C, frosting or icing can occur. This can be prevented by pre-heating the supply air or reducing the

effectiveness of the heat exchanger. Alternatively, the heat exchanger may be periodically defrosted.

Pressure drops depend on a number of factors including exchanger design, airflow rates, temperatures and connections. These pressure drops should be minimised, as they impose a fan energy penalty that will need to be balanced against the recovered energy. Face velocities are normally limited by the need to avoid excessive pressure drops. Larger devices will have lower pressure drops and higher efficiency but will cost more and require more space. The selection and evaluation of heat recovery devices should include the following parameters:

- cost expenditure on device, filters etc. and savings on other plant (e.g. boilers) due to heat recovery
- energy, both recovered and required to operate the system (e.g. fan, pump, wheel)
- maintenance requirements
- space requirements of device, filters etc.

Energy analysis may be undertaken using simulation modelling or spreadsheet calculations based on hourly conditions (see CIBSE AM11: *Building performance modelling* (2015c)). Table 2.13 compares a number of heat recovery devices as described below. Recent guidance on heat recovery is also given in BSRIA HRS 1/2009: *Heat Recovery Systems* (2009b).

Heat recovery within mechanical ventilation systems becomes economic when the value of the recovered heat or cooling outweighs the increase in fan capital and running costs, as well as those of the heat recovery equipment. The viability of heat recovery increases:

- as the number of air changes per hour increases and the heating/cooling season lengthens
- as the temperature difference between supply-and-extract airstreams increases
- with increased proximity of the supply-and-extract airstreams, although it can still be considered when they are not adjacent through the use of a run-around coil.

**Table 2.13** Comparison of heat recovery devices (based on 'Chapter 8: Air-to-air energy recovery' in *ASHRAE Handbook: HVAC Systems and Equipment* (ASHRAE, 2008))

Device	Typical heat recovery efficiency / %	Typical face velocity / m·s <sup>-1</sup>	Cross-leakage / %	Typical pressure drop / Pa	Modulation control	Features
Recuperator	50 to 80 (sensible)	1 to 5	0 to 5	25 to 370	Bypass	No moving parts Easily cleaned
Run-around coil	50 (sensible)	1.5 to 3	0	100 to 500	Pump or bypass valves	Flexibility; exhaust airstream can be separated from supply
Thermal wheel	65 to 90 (total)	2.5 to 5	1 to 10	100 to 170	Wheel speed or bypass	Latent transfer Compact large sizes Cross air contamination possible
Heat pipe	50 to 65 (sensible)	2 to 4	0	100 to 500	Tilt angle down to 10% of maximum	No moving parts except tilt High cost, few suppliers
Regenerator	85 to 95 (sensible)	1.5 to 3	<1 to 5	70 to 300	Regulating changeover period	Relatively high capital cost but high efficiency Self-cleaning action from flow reversal

Heat recovery can increase the overall pressure drop and subsequent fan power used by 50 per cent, although options such as double accumulators offer high heat recovery efficiencies and lower pressure drops.

When heat recovery devices are used in full fresh air systems, parasitic losses should be avoided in summertime operation by the use of a bypass. Effective damper control for minimum fresh air and free cooling on recirculation systems should be provided through enthalpy control.

### 2.3.4.3 Types of systems

Various heat recovery systems are available, including the following.

#### Plate heat exchangers

These contain no moving parts and consist of separated interleaved flow channels through which the exhaust and supply air flows. The channel walls have high thermal conductance to facilitate the rapid transfer of heat (this makes little difference due to the limiting effect of the boundary layers). Maximum heat transfer is achieved with a counter-flow configuration (see Figure 2.19 (a)) in which the direction of flow of the exhaust air is in the opposite direction to the flow of the supply air. Practical heat transfer efficiencies of up to 90 per cent are possible from this configuration only with low velocities. In practical systems a cross-flow arrangement is commonly used in which the flow direction of the exhaust air is at right angles to the supply air (Figure 2.19 (b)). This results in slightly lower efficiency (typically up to 70 per cent) but permits a simple layout.

#### Run-around coils

Finned air-to-water heat exchangers are installed in the ducts between which the heat is to be transferred. A water or water/glycol (for freeze protection) circuit is used to transfer heat from the warm extract air to the cooler supply air (or vice versa in summer) (see Figure 2.20). An expansion tank is required to allow fluid expansion and contraction. Overall heat transfer efficiencies are relatively low, as it is a two-stage heat transfer process, and pump energy (in addition to the fan energy penalty) and maintenance costs need to be taken into account. However, the system is flexible in application, as it places no constraints on the relative location of the two airstreams and can be extended to include multiple sources and uses. They are suitable for applications where contaminants in the exhaust airstream prohibit recirculation.

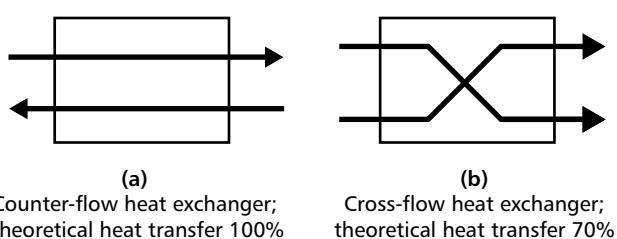

**Figures 2.19** Heat recovery devices: (a) counter-flow and (b) cross-flow (from *Guide to Ventilation* (AIVC, 1996) reproduced by kind permission of AIVC)

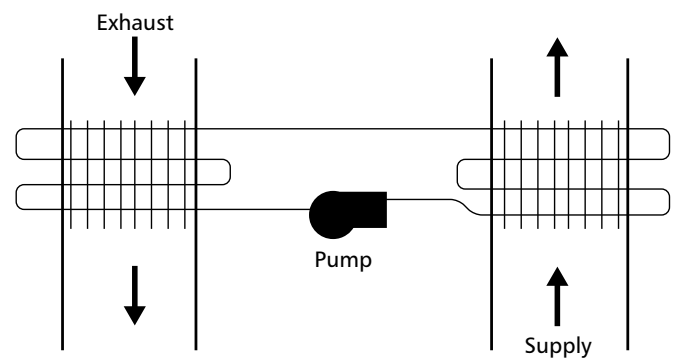

**Figure 2.20** Run-around coil heat recovery method (from *Guide to Ventilation* (AIVC, 1996))

Modulation control can be achieved by pump operation and/or valve bypass arrangements on the coils. These consist of finned heat exchangers located in the supply and exhaust ducts. Heat transfer efficiencies can vary between 40 and 60 per cent.

#### Thermal wheels

A thermal wheel comprises a cylinder packed with a suitable heat transfer medium, which rotates slowly within an airtight casing that bridges the ducts between which heat is to be transferred (see Figure 2.21). Thermal wheels are generally quite compact and achieve high efficiencies due to a counter-flow configuration. The heat transfer properties are determined by the material contained in the wheel, i.e:

- *corrugated, inorganic, fibrous, hygroscopic material that transfers both sensible and latent heat*: air flows through the channels formed by the corrugations
- *corrugated metal (aluminium, stainless steel or Monel)*: latent heat transfer is restricted to that resulting from condensation when the temperature of the heat transfer medium falls below the dew-point temperature of the warm airstream.

Maintenance requirements for the thermal wheel need to be taken into account, since they can be difficult to clean (Hamilton, 1986), as do the additional energy penalties due to the drive (although these are usually low).

Cross-contamination occurs by carryover and leakage. Carryover occurs as air entrained within the wheel is transferred to the other airstream. A purge section can be installed where recirculation is undesirable. Leakage occurs due to the pressure difference between the two airstreams. This can be minimised by avoiding large pressure

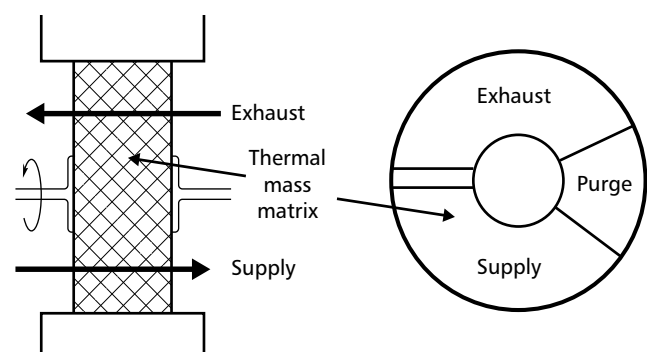

**Figure 2.21** Thermal wheel (from *Guide to Ventilation* (AIVC, 1996) reproduced by kind permission of AIVC)

differences, providing an effective seal and placing the fans to promote leakage into the exhaust airstream. Hygroscopic media may transfer toxic gases or vapours from a contaminated exhaust to a clean air supply.

Modulation control is commonly achieved either by the rotational speed of the wheel or by bypassing the supply air. Heat recovery efficiency increases with wheel speed but is ultimately limited by carryover. This consists of a revolving cylinder packed with a coarse mesh of metal or other highly conducting medium. The cylinder passes through the extract and supply streams with the metallic medium passing heat from one to the other (see Figure 2.21). Some thermal wheel media are designed to absorb moisture thus enabling latent heat as well as sensible heat recovery. Thermal wheels are usually used in large building systems.

*Heat pipes*

The heat pipe is a passive heat exchanger of which there are two main types:

- *horizontal*: in which a wick within the tubes transfers liquid by capillary action
- *vertical*: in which heat from the warmer lower duct is transferred to the cold upper duct by means of a phase change in the refrigerant (see Figure 2.22).

Finned tubes are mounted in banks in a similar manner to a cooling coil. Face velocities tend to be low (e.g. 1.5 to 3.0 m·s<sup>-1</sup>) in order to improve efficiency. Modulation control is normally achieved by changing the slope, or tilt, of the heat pipe.

*Regenerator*

A regenerator (see Figure 2.23) consists of two accumulators (or a single unit split into two halves) with a damper arrangement to cycle the supply and exhaust airflows between the two. In the first part of the cycle, the exhaust air flows through and heats one of the accumulators. The dampers then change over so that supply air flows through and absorbs the heat from that accumulator. The second accumulator acts in reverse to match, heating the supply air in the first part of the cycle and absorbing heat from the exhaust air in the second. The changeover period is normally of the order of one minute.

Claimed sensible efficiencies for these systems can be quite high at 85 per cent. Latent efficiencies are normally significantly lower and vary with flow velocity and accumulator material. Modulation of the heat recovery efficiency can be achieved by regulating the changeover period.

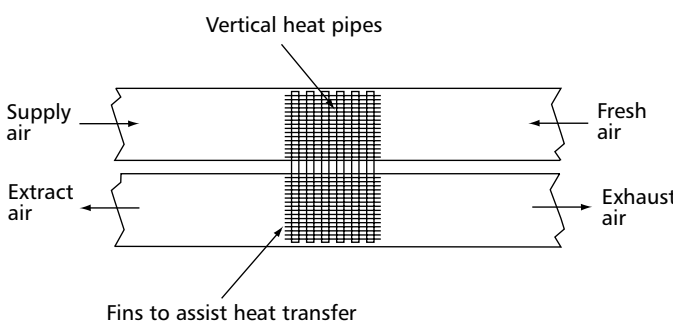

Figure 2.22 Vertical pipe heat arrangement

On damper changeover, the exhaust air contained within the damper, accumulator and exhaust ductwork reverses and becomes supply air. The length of exhaust ductwork should be minimised to limit this cross-leakage. The time required for damper changeover should be kept to a minimum using high torque dampers. Cross-leakage can range from below 1 per cent on well-designed systems to up to 5 per cent and above. Typical face velocities are 1.5 to 3.0 m·s<sup>-1</sup>. Reducing the velocity will reduce the pressure drop, but will have only a limited heat transfer benefit, as efficiencies are normally high anyway.

2.3.4.4 Advantages and disadvantages

*Advantages*

- Heat recovery efficiencies of up to 90 per cent means that a substantial proportion of lost heat from ventilation systems can be recovered. For this reason, significant importance has been attached to heat recovery systems.
- Flat plate heat exchangers are very reliable.
- Performance is best for very cold climates.
- Thermal wheels can be used to recover latent heat and can therefore have valuable applications in air-conditioned spaces.
- Run-around coils enable complex configurations to be considered. Also exhaust heat can be used for other purposes such as the pre-heat of water or connection to a heat pump.
- Properly sized systems can equal the efficiency performance of other system types.

*Disadvantages*

- Buildings need to be very airtight since infiltration adds to the overall air change rate and heat loss through infiltration is not recovered. This can adversely affect overall heat recovery performance. In addition, the quality of airtightness must be maintained throughout the operational lifetime of the building

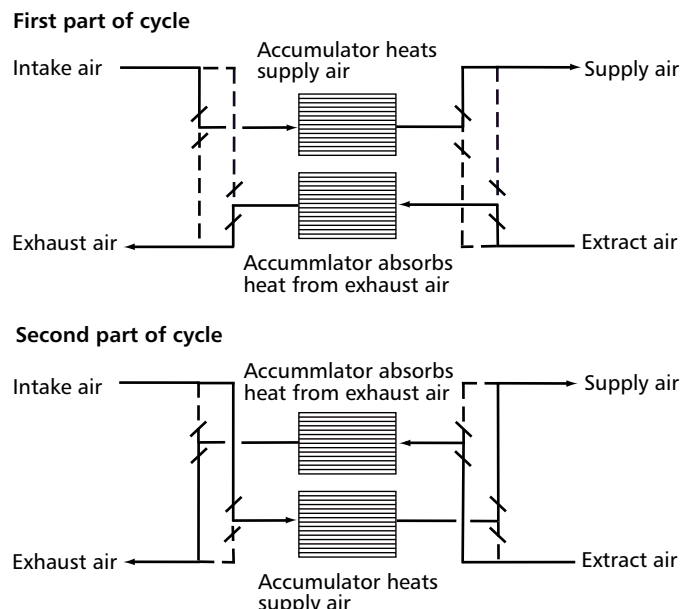

Figure 2.23 Regenerator

- The building must be mechanically ventilated; heat recovery does not work with natural ventilation.
- There are extra costs associated with installation, operation and maintenance.
- Leakage can occur between the supply and exhaust air in the case of thermal wheels. This can be reduced by including a purge zone.

## 2.3.5 Duct systems

### 2.3.5.1 Background

The purpose of duct systems is to convey air to and from spaces as part of a ventilation or air-conditioning system. Designers will need to ensure that the design criteria chosen for ductwork systems, associated air pressurisation devices and other in-line equipment can meet the requirements of Part L of the Building Regulations (NBS, 2013a). Any fire safety issues must also be considered to meet the requirements of Part B of the Building Regulations (NBS, 2013g). It is necessary, by law, to pass on all design, installation and actual position details for any fire protection under regulation 38 of the Building Regulations 2010 (TSO, 2010).

This section is intended to be used by practising designers who hold a basic knowledge of the fundamentals of building physics. As such, rigorous mathematical derivations of formulae are not given. Chapter 4 of CIBSE Guide C: *Reference data* (2007) provides detailed information on pressure drops in ducts and duct fittings. The quantitative data apply to the flow of clean air in ducts, but these may also be used for vitiated air where the concentration of contaminant gas is low. The airflow data should not be applied to the conveyance of particulates in ducts.

Constructional aspects of ductwork are not covered in detail. For the UK, reference should be made to the ductwork specifications published by the Building Engineering Services Association (BESA).

The designer must first fully map the design process that is being undertaken. The process for each application will be unique, but will follow the general format, as follows:

- problem definition
- ideas generation
- analysis
- selection of design solution.

Ductwork types and components are described in detail in section 2.6.7.

### 2.3.5.2 Strategic design issues

#### *Background*

The aim of this section is to provide a source of information on current practice in the design of ductwork for ventilation and air-conditioning systems. The information is intended to provide an overview of design criteria and application requirements.

Duct design must balance the need to minimise energy use and noise generation against space availability and the costs of materials and installation, whilst providing adequate means of access for installation, cleaning and maintenance. Materials, equipment and construction methods should be chosen with respect to the whole-life cycle cost of the installation. This is particularly important for new installations for which Part L of the Building Regulations (NBS, 2013a) sets down strict requirements for maximum fan power. The developing sustainability agenda is imposing new constraints on system performance and therefore designers need to look carefully at energy-efficiency issues.

Users of the environmental space serviced by the ductwork will require:

- sufficient air volume for ventilation
- sufficient air volume delivered and removed to provide either comfort conditions or conditions that satisfy the requirements of the process being served
- satisfactory temperature of delivered air
- satisfactory noise levels within the occupied space due to the ductwork installation
- visual impact of the ductwork in keeping with the internal environment and décor
- that on entry to the space, the air is well diffused and does not cause draughts
- satisfactory air quality
- access to fire-protection systems and equipment, such as fire dampers for cleaning and maintenance; under the Regulatory Reform (Fire Safety) Order (RRFSO) (TSO, 2005), records need to be kept of all such positioning, how to clean and maintain and records of such maintenance.

#### *Classification of ductwork*

Ductwork systems for ventilating and air-conditioning applications can be divided into low-, medium- and high-pressure systems.

High-pressure systems permit smaller ductwork but result in greater friction pressure drop, requiring the fan to generate higher pressures and noise generation. They are more expensive to install and, because of their greater input power requirements, are more expensive to run. This has led to a trend towards lower design pressures in systems.

Table 2.14 sets out the classification of ductwork systems followed in DW/144: *Specification for Sheet Metal Ductwork* (BESA, 2013a). The table also gives air leakage limits (see 'Air leakage limits' in section 2.3.5.2).

The duct air velocity is not a major factor in the constructional specification of ductwork. Recommended velocities for particular applications using these three system classifications are given in Tables 2.16 and 2.17.

It is permissible to operate these systems at velocities higher than the recommended values. DW/144: *Specification for Sheet Metal Ductwork* (BESA, 2013a) limits are up to  $10 \text{ m}\cdot\text{s}^{-1}$ ,  $20 \text{ m}\cdot\text{s}^{-1}$  and  $40 \text{ m}\cdot\text{s}^{-1}$  in the cases of conventional low-, medium- and high-pressure systems respectively.

**Table 2.14** Maximum positive and negative pressures and velocities for low, medium and high-pressure ductwork

System classification	Design static pressure / Pa		Maximum air velocity / m·s <sup>-1</sup>	Air leakage limit per m <sup>2</sup> of duct surface area* / litre·m <sup>-2</sup>
	Maximum positive	Maximum negative		
Low pressure (Class A)	500	500	10	$0.027 \times p^{0.65}$
Medium pressure (Class B)	1000	750	20	$0.009 \times p^{0.65}$
High pressure (Class C)	2000	750	40	$0.003 \times p^{0.65}$
High pressure (Class D)	2000	750	40	$0.001 \times p^{0.65}$

\* where  $p$  is the static gauge pressure in the duct (Pa)

However, since pressure losses go up by square of velocity, thus impacting substantially on fan power, the use of higher velocities than those recommended is not likely to be economic, and the trend is towards lower air velocities.

Two factors influence velocity selection. First, for a given volume flow, velocities should fall as the size of the duct is reduced, to avoid increasing pressure gradients. Second, noise generation increases rapidly with increases in velocity at grilles, bends and other fittings where the flow separates from the walls, leaving turbulent eddies in its wake. The noise generated at grilles and terminals is of particular importance. High-velocity systems require noise control by using sound-absorbent units between the duct system and the room outlets and inlets.

Systems with design pressures outside the values given in Table 2.14 or where the mean duct velocity exceeds 40 m·s<sup>-1</sup> should be treated as special and the designer will need to refer to the original references or other source material to confirm the appropriate design parameters.

### Layout

In most installations, the constraints imposed by the building or other structures (e.g. single or multiple plant rooms, split systems based on tenancy arrangements etc.) and the siting of fans, plant items and terminals can lead to the adoption of an overall duct layout that is not ideal. Room must be given for the installation of fire dampers at compartment boundaries. This should also allow for access for maintenance. The performance of a system can also be adversely affected by a lack of care and thought in the arrangement and detailing of the ductwork. The designer and installer should be aware of the characteristics of airflow in ducts and fittings so that the objectives of the design are compromised as little as possible by the constraints imposed and by space restrictions. In general, good design should ensure that the air velocities are relatively uniform across the duct section and that the generation of eddies in ducts is minimised.

The site will often dictate the main routing of ductwork systems but in general the design should seek to make the layout as symmetrical as possible; that is, the pressure loss in each branch should be as nearly equal as possible. This will aid regulation and may reduce the number and variety of duct fittings that are needed.

The number of duct fittings should be kept to a minimum and there should be a conscious attempt to achieve some standardisation of types and sizes. Increasing the numbers and variety of fittings in a system can markedly raise its overall cost.

The shorter the ductwork length, the lower is the pressure drop. Distribution lengths are influenced by:

- the shape of the building
- the number and location of plant rooms
- the provision of space for distribution.

In large buildings or industrial plants a choice between a single distribution system and multiple smaller systems may arise. Large distribution systems and their plant can have the advantage of lower operating costs but require more floor space for vertical shafts. In general, very long runs of ducting should be avoided to prevent undue heat losses or gains, excessive leakage and difficulties in balancing during commissioning. Also, the pressure losses in long runs are likely to be higher, and a more expensive class of ductwork may be needed. Multiple smaller distribution systems may be more expensive in capital and operating costs but they avoid long runs, large ducts and vertical shafts, and this may reduce overall building costs.

### Spatial requirements

Provision of sufficient space for ductwork is essential and must be addressed at an early stage in the design process of the building.

Laying out the space required for ductwork is, to an extent, an amalgam of experience, skill and three-dimensional visualisation. Adequate space must be provided for installation and maintenance of the ductwork and associated equipment, such as fire dampers at compartment boundaries. The designer should ensure that ductwork is co-ordinated with the other engineering services to be accommodated in the same space, particularly in false ceiling voids and riser spaces where there may be several distribution systems vying for restricted space.

Branches from vertical risers to serve horizontal distribution routes should be considered with care, as this is likely to be the most congested area of the service core. If the service core is enclosed on three sides (e.g. by a lift shaft and an external wall) the horizontal distribution from the core will be extremely difficult, with little space for installation and maintenance.

The area served by a single riser will dictate the size of the horizontal branch duct. The depth selected for a branch duct will have a significant influence on the false ceiling or raised floor depth. It will also affect the overall floor-to-floor heights and hence have significant influence on building costs.

The depth of the horizontal element is a function of the number of vertical risers, generally:

- maximum number of vertical risers equates to minimum horizontal element depth

- minimum number of vertical risers equates to maximum horizontal element depth.

Adequate space must be allowed around ducts for fitting of insulation, hangers and supports during installation and for access during subsequent maintenance. Access will also be dependent on the clearance from adjacent objects such as structural items and the type of jointing method. Suitable allowances are given in Appendix 2.A2, which also shows examples of common problems associated with ductwork access.

Adequate space must also be allowed at compartment boundaries for the installation of fire dampers using a tested installation method. The fire damper installation method to be used should be clearly defined as part of the ductwork/supporting construction design, so that it meets the fire classification of the boundary.

Ductwork clearances can be reduced with care, providing jointing, insulation and maintenance of any vapour barrier is achieved. Consideration should also be given to how the ductwork will be tested and how it will eventually be replaced.

Further information is available in Design and Maintenance Guide 08: *Space requirements for plant access, operation and maintenance* (DEO, 1996), BSRIA TN 10/92: *Spatial Allowances for Building Services Distribution Systems* (1992) and BS 8313: 1997: *Code of practice for accommodation of building services in ducts* (BSI, 1997).

### Aesthetics

Where ductwork is hidden in risers, ceiling voids and below the floor it will not have an effect on the visual environment. In some situations, ducts can be large (e.g. 1–2 m in diameter) and difficult to locate within the overall building design. In such circumstances the ductwork may be exposed and possibly made an architectural feature. The design, including the shape, location and visual appearance, will need to be addressed to ensure sympathy with the visual environment.

Shopping centres, airports, auditoria, display galleries and large office complexes are possible examples where exposed ductwork may be used. Installation standards and sealing systems for such ducts may require more attention to the final appearance of the duct system than with ducts in concealed spaces.

### Approximate sizing

Because ductwork can be large, it will often be necessary to assess the size of individual ductwork in critical locations, particularly where horizontal branches leave the main vertical risers. It is often possible to adjust the size of the vertical space well into the detailed design. Horizontal branches, however, cannot encroach on the necessary headroom.

To make a preliminary estimate of a branch size, calculate the airflow rate required in the area served by multiplying the zone volume by the number of air changes per hour and divide by 3600 to obtain the zone flow rate in  $\text{m}^3\text{s}^{-1}$ . Two air changes an hour may be appropriate for offices with a separate heating system for fabric losses. Where the air is

used for heating, four air changes an hour may be required or six air changes or more for an air-conditioned space. Dividing this flow rate by the velocity given in Tables 2.16 and 2.17 (in ‘Duct air velocities’ in section 2.3.5.3) gives the duct cross-sectional area required. For conventional systems, the aspect ratio (long side to short side) of rectangular ducting should not exceed 3:1.

### Interaction with structure/building form

Because ductwork is likely to be the most space-intensive service provided, it is important that the ductwork design is fully co-ordinated with the design of the building structure to minimise the number of bends and other fittings, each of which will increase the resistance to airflow. The selection of the AHU is also critical (see section 2.6). This is particularly important for new installations for which, for example, Part L of the Building Regulations (NBS, 2013a) sets down strict requirements for maximum specific fan power. The structural design may have reached beyond an outline design and shape by the time that ductwork design commences.

Provided they are allowed for early in the design, it is usually possible to accommodate vertical ducts of any desired size without great difficulty from both structural and planning viewpoints. Horizontal ducts present more problems; if they are located between floors, headroom will be restricted and there will be limits on the floor area that a horizontal duct can serve. Early checks should be carried out to ensure that the vertical main ducts enable horizontal distribution without compromising the performance of the installation or the available headroom and that structural members allow branch ducts to leave the main ducts.

Distribution of the engineering services within a building are likely to follow a pattern associated with the main building circulation route, which represents the main functional pattern of the building. This may not be the most efficient route for the ductwork. The large space requirements for ductwork mean that it can be desirable to locate plant close to the areas they serve.

Sufficient space needs to be provided for ease of fitting the ductwork. Providing access for maintenance is also important since it will be expensive to install retrospectively, whether ducts are horizontal or vertical. Space should also be allowed for additions and alterations. This should include space to fit fire dampers that are suitable to any supporting construction used. The requirements of Part B of the Building Regulations (NBS, 2010g) should be followed. Details of fire damper installation methods are given in DW/145: *Guide to Good Practice for the Installation of Fire and Smoke Dampers* (BESA, 2010) and *Fire Dampers (European Standards)* (‘the ASFP Grey Book’) (ASFP, 2010).

Co-ordination of the engineering services should ensure that the area for removal of access panels and covers and entry into the ductwork is free of services and readily accessible without obstructions.

### Zoning

Loads due to mechanical ventilation of a space are likely to be constant, and zoning, if appropriate, should be based on siting plant as centrally as possible to minimise the distance that the air has to travel. Strategic issues such as availability

of space for multiple plant rooms or the need for separate systems to service different tenants in the building may determine the zoning arrangements.

The ductwork system may be providing heating, cooling or air conditioning, in which case the load will change due to factors such as solar gain, occupancy and the use of lights.

If the loads throughout a building vary together (i.e. are in phase), or the variations are not large enough to cause the internal conditions to drift outside the acceptable limits, a single zone can be adopted. However, if different areas experience load changes that are out of phase, supply air must be provided at a rate or condition appropriate to each zone.

Most deep-plan buildings require division into perimeter and internal zones. The depth of perimeter zones mainly depends on the penetration of sunlight and daylight, which is determined by orientation, external shading, shape and size of windows, characteristics of the glass and the type and pattern of use of blinds. The depth of a typical perimeter zone is 3–6 m.

For a typical multiple-zone system with heating and cooling application, the following should be noted.

- For a constant volume flow rate to be maintained to each zone, the system must be capable of supplying air at various temperatures at any one time; this may involve simultaneous heating and cooling of supply air.
- All rooms with similar solar gain patterns can be zoned together provided that other variables are in phase. However, the number and position of the zonal sensors will be important. Corner rooms pose further problems.
- North-facing rooms experience less variation and can be grouped with internal zones for cooling provided that heating is dealt with by other means.
- Gains through poorly insulated roofs are similar to gains on south-facing surfaces but, if adequately insulated, they may be treated as intermediate floors.

The success of an air-conditioning system depends largely on appropriate zoning and careful positioning of sensors in relation to the sources of heat gains.

#### *Air leakage limits*

It is recommended as good practice that all significant installations (e.g. those with a fan capacity greater than  $1 \text{ m}^3\text{-s}^{-1}$ ) should be tested in accordance with DW/143: *Guide to Good Practice: Ductwork Air Leakage Testing* (BESA, 2013b). Air leakage testing is required by Part L2A of the Building Regulations (NBS, 2013a). Air leakage testing of high-pressure ductwork is mandatory. Refer to BESA (2013b) for details of the testing procedure. Air leakage limits for the four classes of ductwork are given in Table 2.14. The leakage factors given for classes A, B and C are those for the classes similarly designated in European Standards BS EN 12237: 2003: *Ventilation for buildings. Ductwork. Strength and leakage of circular sheet metal ducts* (BSI, 2003a) and BS EN 1507: 2006: *Ventilation for buildings. Sheet metal air ducts. Requirements for strength and leakage* (BSI, 2006a).

Leakage from ducted air-distribution systems is an important consideration in the design and operation of ventilation and air-conditioning systems. A ductwork system having air leakage within defined limits will ensure that the design characteristics of the system can be maintained. It will also ensure that energy and operational costs are not greater than necessary.

Leakage from sheet metal air ducts occurs at the seams and joints and is therefore proportional to the total surface area of the ductwork in the system. The level of leakage is similarly related to the air pressure in the duct system and, whilst there is no precise formula for calculating the level of air loss, it is generally accepted that leakage will increase in proportion to pressure to the power of 0.65.

The effect of air leakage from high-pressure ductwork is critical in terms of system performance, energy consumption and the risk of high frequency noise associated with leakage. These problems are less critical with medium-pressure systems, but should be considered. Low-pressure ducts present the lowest risk in terms of the effect of leakage on the effective operation of the system.

It is important that ductwork should be made as airtight as possible. Conventional sheet metal ductwork is formed by seaming sheets and jointing sections; these seams and joints, penetrations made by damper spindles, control sensors, test holes, access doors etc. all give rise to air leakage. The designer should accept that some leakage will occur in conventional ductwork and make an assessment of the acceptable level in a given system. In some cases it may not be important, for example for a general extract system where the ducting is all in the space being served. In others it may be very important, for example where obnoxious or hazardous contamination is being handled. In the latter case a completely airtight system may be necessary, where fully welded ducting with airtight enclosures at all penetrations could be the basis of a special specification, outside the scope of DW/144: *Specification for Sheet Metal Ductwork* (BESA, 2013a).

For most ventilating and air-conditioning applications, compliance with the construction and sealing requirements of DW/144 (BESA, 2013a) will ensure acceptably low leakage rates. For sheet metal ductwork, the specification requires sealant to be applied to all longitudinal seams (except spirally wound, machine-made seams) and cross-joints; for plastic and resin bonded, glass fibre ductwork, similar sealing requirements are specified. The sheet metal specification also gives details of an air leakage test procedure. Recommended acceptable leakage rates in  $\text{l}\cdot\text{s}^{-1}$  per square metre of surface area are given in Table 2.14.

Appendix 2.A3 shows these limits for a range of duct static pressure differentials. These rates are in accordance with the comparable classes in BS EN 12237 (BSI, 2003a) and BS EN 1507 (BSI, 2006a) but these provisional European Standards do not cover the full range of high-pressure ductwork.

Whilst leakage occurs at seams, joints and penetrations, the purpose of giving acceptable leakage rates in terms of surface area of ductwork is to require that the airtightness is of a consistent standard for air leakage test systems. It does not follow that the total leakage of a system that meets specified leakage requirements will always be a set percentage of the total flow rate; the percentage leakage

from short runs can be substantially less than that from long runs. The design therefore plays a very important part in the likely total leakage loss from ductwork systems, since long runs not only provide more crackage and penetration, but also require higher working pressures to operate. Where limitation of air leakage is important, the designer should first ensure that the duct runs are as short as possible, that the operating pressure is as low as possible, that the number of seams, joints and penetrations is kept to a minimum and that there is adequate room around the ducts for site-made joints to be effectively sealed.

Items of equipment and plant installed in ductwork systems can also leak, and particular attention should be paid to the sealing of these items. Where leakage testing is required, the designer should ensure that suppliers of these items can demonstrate that their equipment meets the required airtightness standards. The designer should make adequate allowance in the fan selection for some air leakage so that the completed installation can meet its intended purpose without subsequent adjustments to the fan(s) and motor(s). Table 2.15 gives some recommendations for margins that should be included for complete installations (i.e. ductwork and equipment).

### System leakage loss

There is no direct relationship between the volume of air conveyed and the surface area of the ductwork system. It is therefore difficult to express air leakage as a percentage of total air volume. Operating pressure will vary throughout the system and, since leakage is related to pressure, the calculations are complex. However, it is generally accepted that, in typical good-quality systems, the leakage from each class of duct under operating conditions will be in the region of:

- *low pressure* (Class A): 6 per cent
- *medium pressure* (Class B): 3 per cent
- *high pressure* (Class C): 2 per cent
- *high pressure* (Class D): 0.5 per cent.

### Designer's calculations

The designer can calculate with reasonable accuracy the predicted total loss from a system by:

- calculating the operating pressure in each section of the system
- calculating the surface area of the ductwork in each corresponding pressure section
- calculating the allowable loss at the operating pressure for each section of the system (see above for indicative leakage figures).

**Table 2.15** Recommended air leakage margins for design figures

Margin	Value of margin for stated class of system / %		
	Low pressure	Medium pressure	High pressure
System total pressure loss margin:	+10	+5	+5
(a) allowance for margin on volume flow rate	+10	+5	+5
(b) allowance for uncertainty in calculation	+10	+10	+10
(c) combined system total pressure loss margin (sum of (a) and (b))	+20	+15	+15

### Variable pressures in systems

Designers can achieve significant cost savings by matching operating pressures throughout the system to constructional standards and appropriate air leakage testing. The practice of specifying construction standards for whole duct systems based on fan discharge pressures may incur unnecessary costs on a project.

For example, some large systems could well be classified for leakage limits as follows:

- *plant room risers*: Class C
- *main floor distribution*: Class B
- *low-pressure outlets*: Class A.

Further information on air leakage is given in section 2.5.4.

### Fan power energy requirements

Fan energy requirements are commonly specified in terms of specific fan power (SFP) which is defined in Building Regulations Approved Document L (NBS, 2013a) as 'the sum of the design total circuit watts including all losses through switchgear and controls such as inverters, of all fans that supply air and exhaust it back to outdoors (i.e. the sum of supply-and-extract fans) divided by the design ventilation rate through the building'.

Energy-efficiency requirements invariably specify maximum SFP values of typically of 2.0 W/litre·s<sup>-1</sup> or less. Actual maximum SFP values should always be checked against the relevant current regulations such as Part L of the Building Regulations (NBS, 2013a).

The formula for calculating fan power is:

$$P_{ef} = \frac{\Delta p_t q_v}{\eta_o} \quad (2.2)$$

where  $P_{ef}$  is the fan power (W),  $\Delta p_t$  is the difference in total pressure around the air circuit (Pa),  $q_v$  is the volume flow (m<sup>3</sup>·s<sup>-1</sup>) and  $\eta_o$  is the overall efficiency (%).

The selection of a fan type is primarily determined by the application and, where a choice is available, the most efficient should be chosen. Fans should be sized as close to the actual demand as possible in order to keep capital and running costs to a minimum. Motors should not be significantly oversized, as efficiency and power factor will reduce. Dependent on the fan type selected, the motor may be located within or external to the duct. Motors within the duct can increase the air temperature.

In general, centrifugal fans are more efficient, more controllable and quieter. Backward-curved centrifugal fans

have high efficiency (up to 80 per cent) with aerofoil backward curved fans providing even higher efficiency. Maximum efficiency for axial flow fans is about 75 per cent. With all fans the efficiency varies with flow rate, so the chosen fan needs to have an operating point close to the point of peak efficiency. This is covered in more detail in section 2.6.

Fan characteristics should be matched to the chosen method of control of volume. This can be achieved by various means, such as variable speed motors to optimise fan performance at part load. Inlet guide vanes, disc throttles and dampers are not generally recommended for energy efficiency due to the 'throttling' effect.

In theory, fans can operate at better than 80 per cent efficiency but in practice less efficient units tend to be specified to save money or provide a safety margin. The loss of efficiency (termed 'fan gains') is dissipated as heat. This can result in an air temperature rise of up to 2 K, which can make the difference between a comfortable building and one that is too warm. Heat will also be dissipated into the ductwork from fan motors located in the duct.

Significant energy savings can be achieved by reducing unnecessary pressure drops in the system by careful sizing, routing and detailing of ductwork. In particular, pinch points in index runs require higher pressure drops than much of the rest of the system.

Variable flow control of air systems, which can be used on most distribution systems, can give considerable savings in fan energy. Variable flow control VAV systems have potentially greater air distribution savings over other central plant systems, provided that pressures are well controlled and air-handling plant and drives are intrinsically efficient.

Variable speed drives also allow rapid matching of fan duties during commissioning and will provide significant savings compared with manual regulation dampers. Typical energy savings are 20 per cent at 90 per cent flow and 40 per cent at 80 per cent flow, dependent upon characteristics. Damper control increases system resistance and therefore energy savings are reduced.

Energy can be reduced in ventilation systems by:

- avoiding unnecessary bends
- using bends instead of mitred elbows
- having a 'shoe' on the branch fittings for tees
- avoiding reduced duct size (i.e. maintain cross-sectional area)
- minimising duct length
- minimising the length of flexible ducting
- good inlet and outlet conditions either side of fan (see fan inlet and outlet below)
- using equipment with low pressure drops (i.e. filters, attenuators, heat exchangers).

Poor inlet and outlet conditions can cause poor fan performance, and hence inefficient operation, often referred to as 'installation effects'. These can alter the aerodynamic characteristics of the fan so that its full potential is not realised. This can be the result of practical difficulties

installing the ductwork and associated equipment, which may not be in exact accordance with the original design routing. Measures to reduce installation effects at the fan inlet and outlet include the following.

(a) Fan inlet:

- Ensure that air enters axial fans without spin by improved inlet design or a by installing a splitter.
- Include turning vanes where there is a duct bend close to a fan inlet.
- Include a transition piece where the duct size reduces.
- Ensure flexible connections are correctly fitted without offset or slack.
- Where fans are installed in plenum chambers, ensure the fan inlet is a minimum of one diameter from the plenum wall with no obstructions.

(b) Fan outlet:

- Ensure a minimum of two diameters of straight duct.
- Where bends are close to the outlet, ensure that radius bends with splitters are used.
- Axial and propeller fans should preferably be fitted with guide vanes to provide energy recovery. (Where guide vanes are not fitted, air swirl will significantly increase system resistance, i.e. pressure drop. This can be corrected by a carefully designed cross-piece.)

Fan connections are considered in detail in section 2.6.1.

### Environmental issues

For a typical air conditioned and mechanically ventilated building, fan energy can consume up to 8 per cent of the electrical consumption and therefore every effort must be made to ensure that the ductwork installation is energy efficient.

Cleaning of ductwork must be taken into account in the design and installation stages by ensuring adequate and safe provision is made for access. Clear guidance is given in BS EN 15780: 2011: *Ventilation for buildings. Ductwork. Cleanliness of ventilation systems* (BSI, 2011b).

Filter removal and replacement must be considered by ensuring sufficient space and means of access is provided. Noise in ductwork can be contentious, particularly where the system or components (e.g. intake, exhaust, AHU etc.) produce a noise nuisance to the building occupants, neighbours or passers-by. Noise is generated where eddies are formed as flow separates from a surface. The generated noise level is particularly sensitive to the velocity. See section 2.5.2.3 and section 2.6 for further details.

The visual effect of ductwork can be an environmental issue because of its physical size and location. Whilst ductwork may be hidden in risers, ceiling voids and below the floor, there will be occasions where it is exposed and possibly made an architectural feature. The design, including the shape, location and visual appearance will need to be addressed to ensure sympathy with the visual environment. Where ducting is exposed, the installation

standards may require additional attention, particularly to jointing and sealing.

### Fire issues

The ventilation system will have fire safety requirements, mainly at compartment boundaries.

Where a standard ventilation duct passes through a supporting construction (wall or floor) designed as a fire compartment boundary, that penetration is required to be protected. This is achieved by using a fire damper specifically tested using an installation method to suit the particular wall (masonry, blockwork, dry wall partition, etc.) or floor that is being used. The classification of the fire damper should meet that of the supporting construction being penetrated by the duct. Fire dampers selected to protect escape routes and areas of sleeping risk are required to act in response to a smoke alarm signal, not just their integral fusible links. They are also required to have an 'ES' classification. To achieve this fire dampers have to have been tested to BS EN 1366-2: 2015: *Fire resistance tests for service installations. Fire dampers* (BSI, 2015a) and classified to BS EN 13501-3: 2005 + A1: 2009: *Fire classification of construction products and building elements. Classification using data from fire resistance tests on products and elements used in building services installations: fire resisting ducts and fire dampers* (BSI, 2005b). ES-classified fire dampers are generally known as fire and smoke dampers.

Fire dampers in other areas should have a minimum 'E' classification (BS EN 1366-2 (BSI, 2015a) and BS EN 13501-3 (BSI, 2005b)) and may close simply under the action of a fusible link.

In the case where all fans are to be turned off in the event of fire, dampers tested to BS 476-20: 1987/BS 476-22: 1987 (BSI, 1987a/b) may be allowed. Note, however, that fire dampers tested to these standards cannot be classified ES, so they must never be used to protect escape routes.

In all cases fire dampers shall be installed following the methods provided by the fire damper manufacturer in line with their testing. Care shall be taken to make sure that there is room to do this and that there is adequate access to the damper for maintenance and cleaning, inside and out.

Further information on fire dampers is available in and *Fire Dampers (European Standards)* ('the ASFP Grey Book') (ASFP, 2010) and DW/145: *Guide to Good Practice for the Installation of Fire and Smoke Dampers* (BESA, 2010).

Where fire-resisting ductwork is used, care must be made that this is installed in the supporting construction using the method of installation recommended by the manufacturer.

Where fire-resisting ductwork is used to protect fire compartments, the junction where it passes through a supporting construction (wall or floor) designed as a fire compartment boundary, the method of sealing the penetration must be made using the method of installation recommended by the manufacturer. This should be proven by using a fire-resisting duct specifically tested using an installation method to suit the particular wall (masonry, blockwork, dry wall partition etc.) or floor that is being used. The classification of the fire-resisting duct shall meet that of the supporting construction being penetrated by it.

Additional restrictions may be specified for the duct in terms of leakage or insulation.

To demonstrate performance, fire-resisting ducts should be tested to BS EN 1366-1: 2014: *Fire resistance tests for service installations. Ventilation* (BSI, 2014a) and classified to BS EN 13501-3: 2005 + A1: 2009 (BSI, 2005b) or tested as a minimum to BS 476-24: 1987: *Fire tests on building materials and structures. Method for determination of the fire resistance of non-loadbearing element of construction* (BSI, 1987c).

Further protection may be made by the use of fire dampers at the end of fire-resisting duct runs.

Further information on fire-resisting ductwork is available in *Fire Rated and Smoke Outlet Ductwork* ('the ASFP Blue Book') (ASFP, 2000).

Where fire doors are used for ventilation, held open by magnetic catches that release on the receipt of a smoke alarm, it must be checked that the equipment meets the required standards and that all closers are correctly tested and set up. All fire doors, frames and associated ironmongery should be installed using the methods defined by the manufacturer. It is recommended that approved installers are used. It should not be assumed that double-leaf doors have the same fire resistance as single-leaf doors and that the inclusion of glazing has been tested; this should be checked.

Further information of fire doors is available from the British Woodworking Federation (BWF) and the Guild of Architectural Ironmongers (GAI).

Guidance to the building regulations with regard to fire safety is given in Part B of the Building Regulations (NBS, 2013g), supported by BS 9999: 2008: *Code of Practice for fire safety in the design, management and use of buildings* (BSI, 2008a). The latter document generally replaces the BS 5588 series. This is supported by CIBSE Guide E: *Fire engineering* (CIBSE, 2010).

Consideration should also be made of the RRFSo (TSO, 2005). This states what is required for a building user to certify their own fire safety. This is generally done by risk assessment, but requires full records of design, selection and maintenance. Supporting this is Part J of the Building Regulations (NBS, 2013f), which requires that all information related to fire safety should be passed on the client/building user. This is represented by, but not limited to, information such as required maintenance schedules, as-built drawings etc. A building regulation is a legal requirement.

*Note:* It is now required that any fire-resisting products used are subject to third-party certification and are CE marked.

### Smoke control

Smoke control is a much broader subject, but it must be noticed that, in the same way as normal ventilation ducts, fire compartments should not be compromised.

Smoke control design requires specialist advice using fire-engineered solutions for the most part. Reference should be made to Approved Document B with supporting documentation being provided from other sources. CIBSE

Guide E: *Fire engineering* (CIBSE, 2010) gives further guidance. A range of other guides are also available from the BRE, ASFP and the Smoke Control Association (SCA).

- BRE Report BR 186: *Design Principles for Smoke Ventilation in Enclosed Shopping Centres* (BRE, 1990).
- BRE Report BR 368: *Design Methodologies for Smoke and Heat Exhaust Ventilation within Atria* (BRE, 1999a).
- BRE Report BR 375: *Natural Ventilation in Atria for Environment and Smoke Control: An Introductory Guide* (BRE, 1999b).
- BRE Project Report 213179: *Smoke Ventilation of Common Access Areas of Flats and Maisonettes (BD2410): Final Factual Report* (BRE, 2005).
- *Fire Rated and Smoke Outlet Ductwork* ('The Blue Book') (ASFP, 2000), European version.
- *Guidance on Smoke Control to Common Escape Routes in Apartment Buildings (Flats and Maisonettes)* (HEVAC, 2012).
- *Design of Smoke Ventilation Systems for Loading Bays and Coach Parks* (HEVAC, 2010).

Any and all equipment used should be checked to confirm compliance with the latest European Standards.

*Note:* It is now required that any smoke control products used are subject to third-party certification and are CE marked.

#### *Weight of ductwork*

The weight of ductwork, including insulation where applied, is normally insignificant in relation to the structural support capability of the structure. In some types of buildings the weight of the ductwork may be important (e.g. lightweight retail, storage and factory structures). Examples of the types of problems are insufficient support centres from which to hang the ductwork and lightweight purlins that are unable to support the weight of the installed ductwork. Sufficient structural support for fans must be provided. Information on the weight of ductwork materials is given in 'Weight of ductwork' in section 2.3.5.2.

#### *Testing, commissioning, cleaning and maintenance*

It is essential for duct systems to be commissioned, kept clean and regularly maintained. These issues are considered in relation to HVAC systems in general in section 2.7.1.

#### *Controlling costs*

Lower first costs can be achieved by:

- using the minimum number of fittings possible; fittings can be expensive and the resulting pressure loss is far greater than for straight duct sections
- ensuring ductwork is sealed to minimise air leakage; this allows reduction in both equipment and ductwork size
- using round ductwork where space and initial costs allow because it offers the lowest duct friction loss for a given perimeter or given velocity

- when using rectangular ductwork, maintaining the aspect ratio as close as possible to 1:1 to minimise duct friction losses and initial cost; this can also avoid problems with 'difficult' elbows.

### 2.3.5.3 Design criteria

#### *Introduction*

The primary function of a ductwork system is to convey air between specific points. In fulfilling this function, the duct assembly must perform satisfactorily within fundamental performance characteristics. One of the most important performance characteristics is energy efficiency. This aspect is particularly relevant because changes to Part L of the Building Regulations (NBS, 2013a) imposed new performance constraints on air-moving systems and equipment. Early in the process, designers need to ensure that their design can meet the overall performance requirements of Part L. The energy-efficiency standards of Part L should not be regarded as an absolute target. In many situations, an improved level of performance may be beneficial in terms of whole-life cost and/or as a means of providing a trade-off opportunity to offset against another aspect of the design where achieving the required standard of energy efficiency is more difficult or more costly.

Elements of the assembly include an envelope (e.g. sheet metal or other material), reinforcement, seams, joints, support hangers and, possibly, insulation. Performance limits must be established for:

- dimensional stability
- containment of air
- vibration
- noise generation and containment
- exposure to damage, weather, temperature extremes
- support
- emergency conditions, e.g. fire
- heat gain or loss to the airstream
- adherence to duct walls of dirt and contaminants.

Due consideration must be given to the effects of differential pressure across the duct wall, airflow friction pressure losses, dynamic losses and air velocity leakage, as well as the inherent strength characteristics of the duct components. Ductwork installations can account for a significant proportion of the cost of mechanical services. Ducts should be sized and constructed in accordance with recognised sources of data and standards of construction.

#### *Duct air velocities*

The velocity of air flowing through a duct can be critical, particularly where it is necessary to limit noise levels. The duct air velocity is not a major factor in the constructional specification of ductwork.

Recommended velocities for particular applications, using the BESA system classifications, are given in Tables 2.16 and 2.17. These figures are a general guide and assume reasonable distances between the fittings (e.g. four times the duct hydraulic diameter). Higher velocities may be

used if additional attenuation is employed. Maximum velocities, as stated in DW/144: *Specification for Sheet Metal Ductwork* (BESA, 2013a) are given in Table 2.14.

Table 2.18 gives recommended maximum air velocities for rectangular and circular ducts in risers and ceiling spaces. Table 2.19 gives recommended velocities for supply and return air openings.

**Legislation**

No legislation has been produced that relates specifically to ductwork. The general requirements of the Health and Safety at Work etc. Act (HMSO, 1974) and the Construction (Design and Management) Regulations 2015 (TSO, 2015) will apply during all the stages of design, installation, commissioning, operation, maintenance and finally demolition and disposal. Part L of the Building Regulations (NBS, 2013a) includes limitations on specific fan power. These are described in ‘Fan power energy requirements’ in section 2.3.5.2. Part B of the Building Regulations (NBS, 2013g) gives full details on fire-safety issues with regard to ductwork and fire dampers. Building Regulation 38 requires that all information on all aspects of fire protection, installation, positioning, maintenance etc. be passed on to the building owner. The latter is the law.

**Health and safety**

Health considerations will be addressed if a good inspection, maintenance and cleaning regime is applied. Further information on cleaning is provided in section 2.7.2.3.

Three aspects of safety concerning ductwork need to be addressed:

- *During design:* that there are safe and secure means of access to the ductwork and associated plant and

**Table 2.16** Recommended maximum duct velocities for low-pressure ductwork systems where noise generation is the controlling factor

Typical applications	Typical noise rating (NR)*	Velocity / m·s <sup>-1</sup>		
		Main ducts	Branch	Run-outs
Domestic buildings (bedrooms)	25	3.0	2.5	<2.0
Theatres, concert halls	20–25	4.0	2.5	<2.0
Auditoria, lecture halls, cinemas	25–30	4.0	3.5	<2.0
Bedrooms (non-domestic buildings)	20–30	5.0	4.5	2.5
Private offices, libraries	30–35	6.0	5.5	3.0
General offices, restaurants, banks	35–40	7.5	6.0	3.5
Department stores, supermarkets, shops, cafeterias	40–45	9.0	7.0	4.5
Industrial buildings	45–55	10.0	8.0	5.0

\* See CIBSE Guide A (2015a), Table 1.16

**Table 2.18** Guide to maximum duct velocities in risers and ceilings

Duct location	Duct type	Maximum air velocity / m·s <sup>-1</sup> for stated room type		
		Critical	Normal	Non-critical
Riser or above plasterboard ceiling	Rectangular	5	7.5	10
	Circular	7	10	15
Above suspended ceiling	Rectangular	3	5	6
	Circular	5	7	10

equipment (e.g. filter housings) for inspection, maintenance and cleaning.

- *During installation:* by ensuring that the ductwork can be installed safely and securely.

- *During building operation:* that maintenance and fire protection are maintained.

Fibrous materials were often used as duct linings to provide sound absorption. However, they are not now generally used because:

- they can contribute to mould growth
- fibrous materials degrade with time
- fibres can erode from the surface and be carried in the air
- fibrous materials are difficult to clean.

Suitable alternative sound-absorbing proprietary materials such as acoustic foam are now used and have the advantage of not requiring facings or edge treatment.

**2.3.5.4 Airflow in ducts**

**General**

Air in ducts follows natural laws of motion. While the detailed prediction of flow behaviour is very difficult, good design should ensure that the air follows the line of the duct with uniform velocities and that excessive turbulence is avoided. Ductwork fittings cause major pressure losses and good design is essential, particularly where higher velocities are used. Bad design in relation to airflow can lead to vibration of flat duct surfaces, increases in duct pressure losses, unpredictable behaviour in branch fittings and terminals, and adverse effects on the performance of

**Table 2.17** Recommended maximum duct velocities for medium and high-pressure systems

Volume flow in duct / m <sup>3</sup> ·s <sup>-1</sup>	Velocity / m·s <sup>-1</sup>	
	Medium-pressure systems	High-pressure systems
<0.1	8	9
0.1–0.5	9	11
0.5–1.5	11	15
>1.5	15	20

**Table 2.19** Maximum velocity for supply and return air openings (grilles and terminals)

Supply or return air	Permitted air velocity / m·s <sup>-1</sup>		
	Critical	Normal	Uncritical
Supply	1.5	2.5	3
Return	2	3	4

installed plant items such as fans and dehumidifying coils. It is much cheaper to get the design right than to try and correct abnormal flow situations on-site.

### Behaviour of air flowing through a duct

In normal circumstances the flow of air in ducts is turbulent with the flow generally in the direction of the duct axis. Eddies and secondary motions will result in energy dissipation due to internal fluid friction. Streamlines will not be parallel to the duct centre-line. In unobstructed straight ducts, eddies give rise to only relatively small transverse components of the duct velocity and the flow velocities are symmetrical about the duct axis.

Disturbance to the flow arising from obstructions, duct fittings or other components has two major effects:

- the eddies can be significantly larger in size and their velocities much higher
- the flow velocities across the duct become asymmetrical, i.e. much higher velocities can occur in part of the duct section, whilst in other parts even reverse flow may occur.

From the point of view of duct design the important aspects of the effects of disturbance to airflow are:

- increased pressure loss due to creation of eddies
- increased pressure loss as high-velocity air mixes with low-velocity air
- noise generated by the interaction on eddies with the inner surfaces of the ducts.

More information on the flow characteristics through duct components and fittings is given in section 2.6.

### Heat gains or losses

In a duct system, the air temperature change can be significant, e.g. when passing through an untreated space. This has the effect of reducing the heating or cooling capacity of the air and increasing the energy input to the system. The heat transmission to and from the surrounding space can be reduced by insulation of the ducts. The following notes give guidance on the estimation of temperature changes in ducted air due to heat gains or losses.

The heat gain or loss rate through the walls of a run of air ducts is given by:

$$\Phi = U A_s (t_{ad} - t_{as}) \quad (2.3)$$

where  $\Phi$  is the heat exchange (W),  $U$  is the overall thermal transmittance ( $\text{W}\cdot\text{m}^{-2}\cdot\text{K}^{-1}$ ),  $A_s$  is the surface area of the duct run ( $\text{m}^2$ ),  $t_{as}$  is the ambient temperature outside the duct ( $^{\circ}\text{C}$ ) and  $t_{ad}$  is the temperature of the air inside the duct ( $^{\circ}\text{C}$ ).

The temperature of the air inside the duct is given by:

$$t_{ad} = 1/2 (t_{ad1} + t_{ad2}) \quad (2.4)$$

where  $t_{ad1}$  is the air temperature in the upstream end of the duct run ( $^{\circ}\text{C}$ ) and  $t_{ad2}$  is the air temperature in the downstream end of the duct run ( $^{\circ}\text{C}$ ).

The duct surface area is given by:

$$A_s = P \times l \quad (2.5)$$

where  $A_s$  is the duct surface area ( $\text{m}^2$ ),  $P$  is the perimeter of the duct cross section (m) and  $l$  is the length of the duct run (m).

The heat gain or heat loss rate given by equation 2.3 is equal to the heat gain or loss rate from the air in the duct, which is given by:

$$\Phi = c A \rho c_p \Delta t_{ad} \times 10^3 \quad (2.6)$$

where  $c$  is the velocity of the air in the duct ( $\text{m}\cdot\text{s}^{-1}$ ),  $A$  is the cross-sectional area of the duct ( $\text{m}^2$ ),  $\rho$  is the density of air in the duct ( $\text{kg}\cdot\text{m}^{-3}$ ),  $c_p$  is the specific heat capacity of air in the duct at constant pressure ( $\text{kJ}\cdot\text{kg}^{-1}\cdot\text{K}^{-1}$ ) and  $\Delta t_{ad}$  is the temperature difference between the ends of the duct run (K).

$\Delta t_{ad}$  is given by:

$$\Delta t_{ad} = t_{ad1} - t_{ad2} \quad (2.7)$$

Equating equations 2.2 and 2.5 and rearranging gives:

$$\Delta t_{ad} = \frac{U P (t_{ad} - t_{as}) l}{c A \rho c_p 10^3} \quad (2.8)$$

or:

$$\Delta t_{ad} = \frac{4 U (t_{ad} - t_{as}) l}{c \rho c_p d_h 10^3} \quad (2.9)$$

where  $d_h$  is the hydraulic mean diameter of the duct (m).

The hydraulic mean diameter is given by:

$$d_h = 4 A / P \quad (2.10)$$

For air at  $20^{\circ}\text{C}$ ,  $\rho = 1.2 \text{ kg}\cdot\text{m}^{-3}$  and  $c_p = 1.02 \text{ kJ}\cdot\text{kg}^{-1}\cdot\text{K}^{-1}$ . Hence, by substituting these values and combining the numerical factors:

$$\Delta t_{ad} = \frac{U (t_{ad} - t_{as}) l}{306 c d_h} \quad (2.11)$$

Ignoring the thermal resistance of the duct material, the  $U$ -value of the insulated duct is given by:

$$U = \frac{1}{(1/h_{si} + l_n/\lambda_n + 1/h_{so})} \quad (2.12)$$

where  $h_{si}$  is the heat transfer coefficient of the inside surface of the duct ( $\text{W}\cdot\text{m}^{-2}\cdot\text{K}^{-1}$ ),  $l_n$  is the insulation thickness (m),  $\lambda_n$  is the thermal conductivity of the insulation ( $\text{W}\cdot\text{m}^{-1}\cdot\text{K}^{-1}$ ) and  $h_{so}$  is the heat transfer coefficient of the outside surface of the duct ( $\text{W}\cdot\text{m}^{-2}\cdot\text{K}^{-1}$ ).

The value of  $h_{si}$  is a function of the Reynolds number and an approximate value is given by:

$$h_{si} = 3.5 (c^{0.8} / d_h^{0.25}) \quad (2.13)$$

For most typical applications,  $h_{si}$  may be taken as  $37.5 \text{ W}\cdot\text{m}^{-2}\cdot\text{K}^{-1}$ . The value of  $h_{so}$  also depends on the conditions surrounding the duct. A typical value for unvented building voids is  $10 \text{ W}\cdot\text{m}^{-2}\cdot\text{K}^{-1}$ , but this can be influenced by reflective facing materials on the insulation and by draughts. Estimated values of  $U$  for insulated ducts with these values of  $h_{si}$  and  $h_{so}$  are given in Table 2.20.

The temperature change in an insulated duct can be estimated from equation previous 2.11 and Table 2.12. For insulation with thermal conductivity of  $0.045 \text{ W}\cdot\text{m}^{-1}\cdot\text{K}^{-1}$  values of  $(\Delta t_{ad}/l(t_{ad} - t_{as}))$  are given in Figure 2.24. The approximate values for an uninsulated duct are also shown in Figure 2.24, for typical still locations, but these temperature changes could be underestimated by about 20 per cent if the duct is in draughty conditions.

### Example 2.1

For a 600 mm × 500 mm duct with 50 mm of thermal insulation ( $\lambda_n = 0.045 \text{ W}\cdot\text{m}^{-1}\cdot\text{K}^{-1}$ ), an air velocity inside the duct of  $9.5 \text{ m}\cdot\text{s}^{-1}$  and an air temperature  $t_{ad} = 10^\circ\text{C}$ , passing through surroundings at  $t_{as} = 30^\circ\text{C}$ , the change in air temperature per metre run is calculated as follows.

Cross sectional area of duct:

$$A_s = 0.6 \times 0.5 = 0.3 \text{ m}^2$$

Perimeter of duct:

$$P = 2(0.6 + 0.5) = 2.2 \text{ m}$$

Hydraulic diameter of duct:

$$d_h = (4 \times 0.3)/2.2 = 0.55 \text{ m}$$

Hence:

$$d_h c = 0.55 \times 9.5 = 5.23 \text{ m}^2\cdot\text{s}$$

From Figure 2.24:

$$\Delta t_{ad}/l(t_{ad} - t_{as}) = 0.0005 \text{ m}^{-1}$$

Hence the change in air temperature per metre of duct run is:

$$\Delta t_{ad} = 0.0005 \times 20 = 0.01 \text{ K}\cdot\text{m}^{-1}$$

For an uninsulated duct, from Table 2.20:

$$\Delta t_{ad}/l(t_{ad} - t_{as}) = 0.004 \text{ m}^{-1}$$

Therefore:

$$\Delta t_{ad} = 0.004 \times 20 = 0.08 \text{ K}\cdot\text{m}^{-1}$$

Since this method assumes that  $\Delta t_{ad}$  is small, some error will be introduced if the length of ductwork is considered large, and the smaller the value of  $(d_h \times c)$ , the larger the error. A maximum length of 10 m is recommended. It may be noted from Figure 2.24 that as the value of  $(d_h \times c)$  falls below 1.5, the rate of temperature drop in the ducts with 50 mm or less insulation increases considerably. For small ducts and low air velocities, the insulation thickness should be at least 50 mm. BS 5422: 2009: *Method for specifying thermal insulating materials for pipes, tanks, vessels, ductwork and equipment operating within the temperature range  $-40^\circ\text{C}$  to  $+700^\circ\text{C}$*  (BSI, 2009b) gives guidance on the assessment of the economic thickness of duct insulation. However, in the absence of such assessment, BS 5422: 2009 recommends insulation thicknesses for ducts carrying chilled and warm air as shown in Tables 2.21 and 2.22 respectively. For detailed information on the thermal insulation of ductwork, see BS 5422: 2009 and BS 5970: 2012: *Thermal insulation of pipework, ductwork and other industrial installations in the temperature range  $-100^\circ\text{C}$  to  $+870^\circ\text{C}$ . Code of practice* (BSI, 2012b).

### 2.3.5.5 Condensation and vapour barriers

Condensation of water vapour within air occurs whenever the temperature falls below the ambient dew-point. This can occur on the outside of the cold duct when the temperature of the duct air causes the duct itself to have a temperature below the dew-point of the surrounding air. Even when the ductwork is insulated, this can occur due to diffusion through the insulation of the more humid air external to the duct. In turn this can lead to corrosion of the ductwork as well as diminishing the thermal resistance of the insulation, leading to more condensation.

Vapour sealing will be required where the temperature of the air within the duct is at any time low enough to promote condensation on the exterior surface of the duct and cause moisture penetration through the thermal insulation. In this case the most important requirement is to limit penetration of the seal. The vapour barrier must be carefully installed to ensure the seal is continuous with no routes for penetration of humidity.

BS 5970: 2012 (BSI, 2012b) warns of the risk of condensation within the layer of insulation, which is primarily used to avoid condensation on its outside surfaces. With a suitable choice of insulation material and thickness, the surface temperature of the ductwork can be raised sufficiently above the ambient dew-point temperature to avoid surface condensation on the duct.

The extent of any vapour sealing of ductwork thermal insulation and the support method to be used should be clearly specified in advance by the designer.

**Table 2.20** Estimated  $U$ -value for insulated ducts

Thermal conductivity of insulation / $\text{W}\cdot\text{m}^{-1}\cdot\text{K}^{-1}$	$U$ -value ( $/\text{W}\cdot\text{m}^{-2}\cdot\text{K}^{-1}$ ) for given thickness of insulation/mm				
	25	38	50	75	100
0.025	0.89	0.61	0.47	0.32	0.24
0.03	1.04	0.72	0.56	0.38	0.29
0.035	1.19	0.82	0.64	0.44	0.34
0.04	1.33	0.93	0.73	0.50	0.38
0.045	1.47	1.03	0.81	0.56	0.43
0.05	1.6	1.13	0.89	0.61	0.47
0.055	1.72	1.22	0.97	0.67	0.51
0.06	1.84	1.32	1.04	0.73	0.56
0.07	2.07	1.49	1.19	0.83	0.64
0.08	2.28	1.66	1.33	0.94	0.73

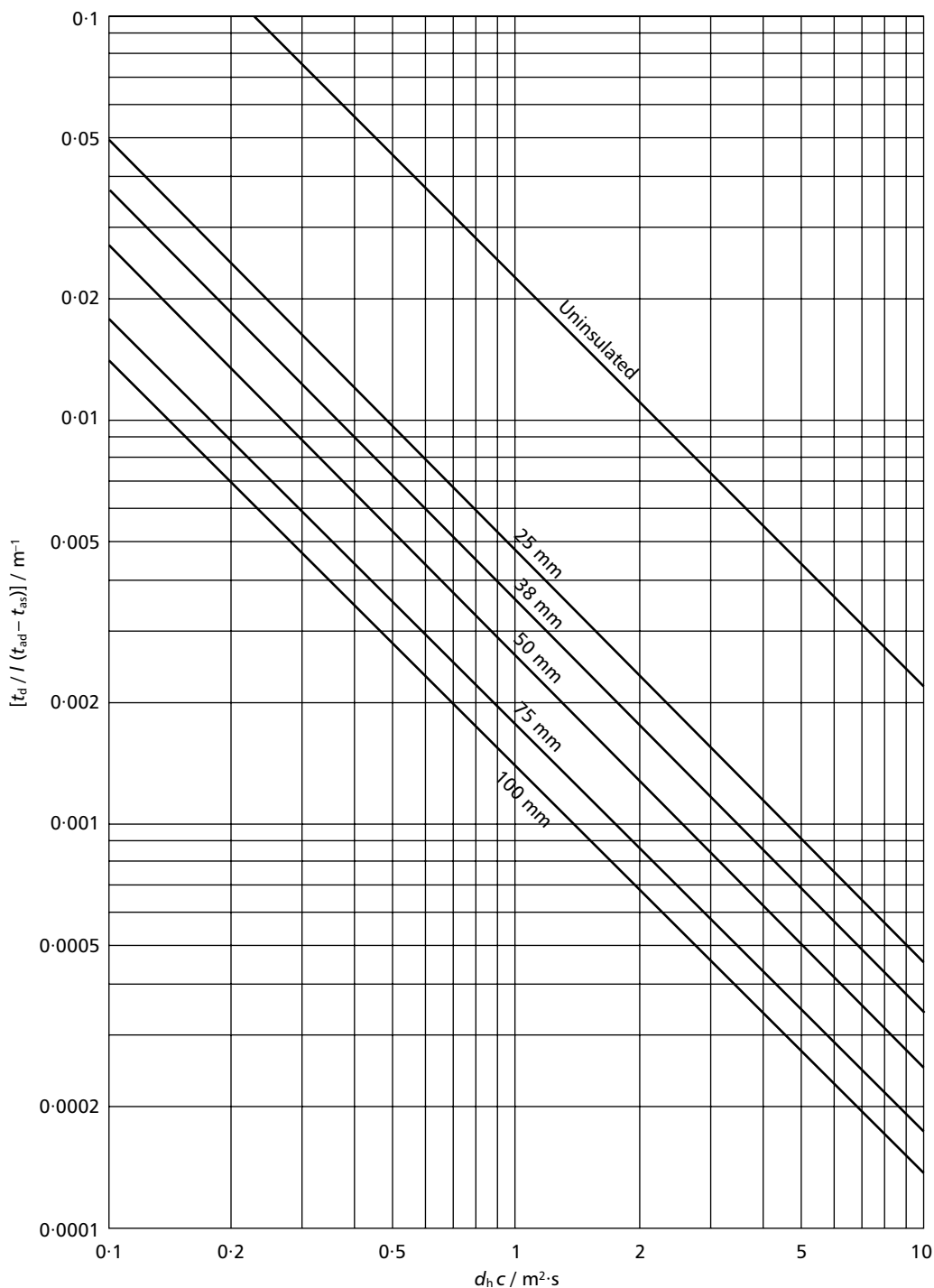

**Figure 2.24** Temperature change along insulated ducts for various thicknesses of insulation

**Table 2.21** Recommended minimum thickness of insulation on ductwork carrying chilled air (see BS 5422: 2009 (BSI, 2009b))

Minimum air temp. inside duct/°C	Minimum thickness of insulating material (mm) for stated thermal conductivity $\lambda / \text{W}\cdot\text{m}^{-1}\cdot\text{K}^{-1}$ and external surface emissivity $\epsilon$											
	$\lambda = 0.02$			$\lambda = 0.025$			$\lambda = 0.03$			$\lambda = 0.035$		
	$\epsilon = 0.05$	$\epsilon = 0.44$	$\epsilon = 0.9$	$\epsilon = 0.05$	$\epsilon = 0.44$	$\epsilon = 0.9$	$\epsilon = 0.05$	$\epsilon = 0.44$	$\epsilon = 0.9$	$\epsilon = 0.05$	$\epsilon = 0.44$	$\epsilon = 0.9$
15	15	8	5	18	9	6	22	11	7	25	13	8
10	26	10	9	32	17	11	39	20	13	45	23	15
5	37	19	12	47	24	15	56	28	18	64	33	21
0	48	25	16	60	31	20	72	37	24	84	43	27

Minimum air temp. inside duct/°C	Minimum thickness of insulating material (mm) for stated thermal conductivity $\lambda / (\text{W}\cdot\text{m}^{-1}\cdot\text{K}^{-1})$ and external surface emissivity $\epsilon$								
	$\lambda = 0.04$			$\lambda = 0.045$			$\lambda = 0.05$		
	$\epsilon = 0.05$	$\epsilon = 0.44$	$\epsilon = 0.9$	$\epsilon = 0.05$	$\epsilon = 0.44$	$\epsilon = 0.9$	$\epsilon = 0.05$	$\epsilon = 0.44$	$\epsilon = 0.9$
15	29	15	10	32	17	11	36	18	12
10	52	26	17	58	29	19	64	33	21
5	75	38	24	83	42	27	92	47	30
0	96	49	31	108	56	35	120	61	39

Notes: (a) assumes ambient conditions of 25 °C still air, 80% relative humidity, dew-point temperature 21.3 °C; (b) thicknesses calculated in accordance with BS EN ISO 12241: 1998: *Thermal insulation for building equipment and industrial installations* (BSI, 1998) based on 0.6 m vertical flat surface of rectangular duct but are also adequate for horizontal surfaces; (c) Thermal conductivity values of insulating materials quoted at mean temperature of 10 °C.

**Table 2.22** Indicative thickness of insulation for ductwork carrying warm air to control heat loss (based on BS 5422: 2009: (BSI, 2009b))

Surface emissivity	Thermal conductivity of insulation (mm) for stated thermal conductivity $\lambda / (\text{W}/\text{m}\cdot\text{K})$							Maximum permissible heat loss / $\text{W}\cdot\text{m}^{-2}$
	$\lambda = 0.020$	$\lambda = 0.025$	$\lambda = 0.030$	$\lambda = 0.035$	$\lambda = 0.040$	$\lambda = 0.045$	$\lambda = 0.050$	
Low ( $\epsilon = 0.05$ )	17	21	25	29	33	38	42	16.34
Medium ( $\epsilon = 0.44$ )	21	26	31	36	41	46	51	16.34
High ( $\epsilon = 0.90$ )	22	27	33	38	44	49	54	16.34

Notes: (a) heat loss relates to specified thickness and temperature; (b) insulation thickness in this table has been calculated according to BS EN ISO 12241: 1998 using standardised assumptions: horizontal duct at 35 °C, with 600 mm vertical sidewall in still air at 15 °C, emissivity of outer surface of insulated system as specified.

The thickness of insulation to prevent surface condensation can be determined from the following approximate equations governing solid state heat transfer:

For rectangular ducts:

$$l_n = \frac{(t_{ds} - t_{ad})\lambda}{(t_{as} - t_{ds})h_{so}} \tag{2.14}$$

where  $l_n$  is the insulation thickness (m),  $t_{ds}$  is the ambient dew-point temperature of the air outside the duct (°C),  $t_{ad}$  is the temperature of the air inside the duct (°C),  $\lambda$  is the thermal conductivity of the insulation ( $\text{W}\cdot\text{m}^{-1}\cdot\text{K}^{-1}$ ),  $t_{as}$  is the ambient temperature outside the duct (°C) and  $h_{so}$  is the heat transfer coefficient of the outside surface of the duct ( $\text{W}\cdot\text{m}^{-2}\cdot\text{K}^{-1}$ ).

**Example 2.2**

Calculate the thickness of glass wool ( $\lambda = 0.045 \text{ W}\cdot\text{m}^{-1}\cdot\text{K}^{-1}$ ) to prevent surface condensation on a circular duct of diameter 0.8 m, carrying cooled air at 12 °C, exposed in a ceiling void at 35 °C with relative humidity of 85%.

From a psychrometric chart, for a dry bulb temperature of 35 °C and 85% RH:

$$t_{ds} = 32.1 \text{ °C}$$

Taking  $h_{so}$  as  $10 \text{ W}\cdot\text{m}^{-2}\cdot\text{K}^{-1}$ , using equation 2.14, the required thickness is:

$$l_n = \frac{(32.1 - 12) \times 0.045}{(35 - 32.1) \times 10} = 0.030 \text{ m} = 30 \text{ mm}$$

Table 2.21 recommends an insulation thickness of 50 mm. Hence the glass wool thickness required for vapour resistance is less than that recommended for thermal insulation and surface condensation should not arise under these operating conditions.

**Vapour barriers**

In normal circumstances the insulation thickness for heat resistance is sufficient to prevent surface condensation, but in extreme conditions the insulation thickness for vapour resistance may be larger than that for heat resistance. When cold ducts pass through areas of high dew-point, carefully selected vapour barriers should be applied externally to the

insulation. Well-installed vapour barriers with sealed joints will minimise vapour penetration and combat the risk of internal condensation in the insulation. It is good practice to provide 'nominal' vapour barriers to cold ducts or to use thermal insulation with a low value of permeability, even when the insulation thickness for vapour resistance is less than that which is recommended for thermal resistance. Although polystyrene foam provides a high resistance to vapour transfer, other thermal insulation materials, for example rock wool, have minimal vapour resistance (see Hayden and Parsloe (1996), Table 3.49).

There are three main types of vapour barrier:

- *rigid barriers*: such as reinforced plastics and sheet metal, which are erected by mechanical means with sealed joints and suitable protection to resist impact damage
- *membrane barriers*: such as metal foils, plastic films and coated papers, which are easier to install and are in many cases available as backing material with heat-resisting insulation but are more easily damaged
- *coating barriers*: which are usually available as paints, hot melts, pastes or powders with chemical hardeners.

Vapour barriers need to be effective and continuous. The slightest leak will permit water vapour to diffuse throughout the insulation. It is therefore imperative that cracks in vapour barriers due to poor workmanship or thermal forces

are avoided. This is not normally a significant problem because  $\Delta t$  is often small.

A common problem is that accidental damage to barriers caused by maintenance workers is subsequently not rectified.

### 2.3.5.6 Duct and plenum design

Air terminal devices will only perform as intended if the approach velocity is even. If the duct connections and/or volume flow regulators created eddies at the terminal, the following problems may arise:

- unpredictable throw, spread and drop
- breakdown of Coanda effect
- high noise levels
- balancing is difficult or impossible.

Design procedures for duct and plenum connections to various types of air terminal are given elsewhere (HEVAC, 2000); also see section 2.6.8.

If the ceiling is to be used as an exhaust plenum, it is important to create a uniform negative pressure throughout the whole ceiling void to ensure even exhaust throughout all terminals. This is particularly important where exhaust is by means of air-handling luminaires, the performance of which varies with airflow rate. Ceiling voids should be made as large as possible and, if

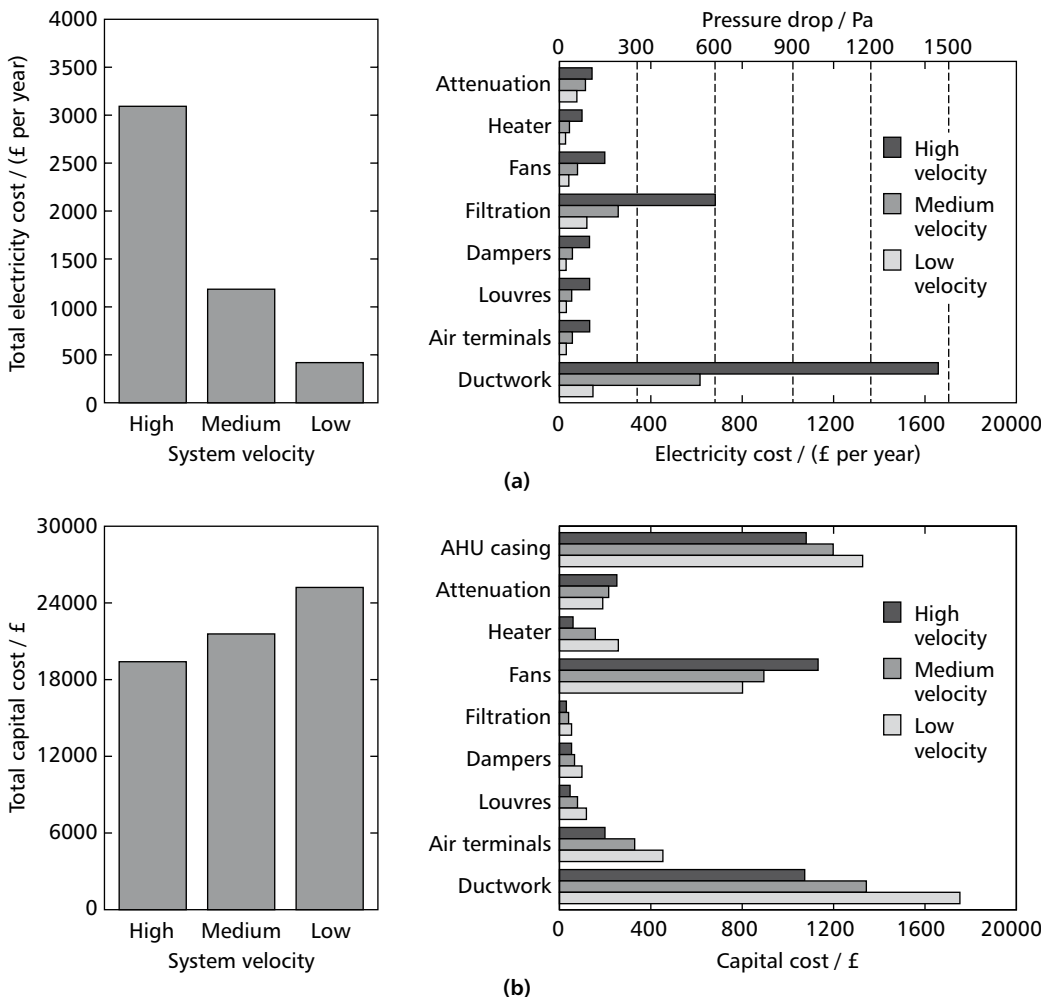

Figure 2.25 Comparison of high, medium and low-velocity systems (Action Energy, 1997); (a) electricity costs (b) capital costs

obstructed by luminaires, ductwork etc., exhaust stub ducts should be provided to ensure even exhaust over the full ceiling area.

### 2.3.5.7 Ductwork and system velocities

Optimising duct design is essential for achieving energy efficiency. For optimum energy efficiency ductwork should have as large a cross-sectional area as possible to produce low-velocity systems and reduce system pressure drops. Figure 2.25 which is based on Jackman (1990) and Good Practice Guide GPG 257 (Action Energy, 1997) illustrates the running and capital costs for systems having different design air velocities. These figures show how the running costs are reduced for low-velocity systems and how some components become more expensive while others become cheaper. The benefits of the energy-efficient (i.e. low-velocity) system include a reduction in electricity costs of approximately 70 per cent, while the additional capital cost is recovered in under five years.

The basis of the comparison is as follows:

- all systems supplying 2 m<sup>3</sup>·s<sup>-1</sup> of air
- all systems supplied by a centrifugal fan operating at an efficiency of 70 per cent
- pulley and motor efficiencies of 90 per cent and 80 per cent respectively
- electricity cost: 10 pence per kW·h
- annual run time: 3000 hours
- noise levels less than 40 dBA.

In a low-velocity system, the AHU face velocity would typically be less than 2 m·s<sup>-1</sup> with the main duct velocity less than 3 m·s<sup>-1</sup>. In a medium-velocity system these figures would become 2–3 m·s<sup>-1</sup> and 5 m·s<sup>-1</sup> respectively. In a high-velocity system the AHU velocity would typically be greater than 3 m·s<sup>-1</sup> with the main duct velocity at 8 m·s<sup>-1</sup>.

Air leakage from ductwork should be minimised to prevent the wastage of fan power. Ductwork should be insulated accordingly and runs through unoccupied spaces should be minimised. Testing of ductwork air tightness should be undertaken (see DW/143: *Guide to Good Practice: Ductwork Air Leakage Testing* (BESA, 2013b)).

Good duct design should achieve airflow that is as uniform as possible throughout the ductwork run to reduce the pressure drop. To achieve this:

- changes to the direction of the flow should be minimised
- where possible 2–3 diameters of ductwork should be allowed either side of components before changing direction
- radius bends should be used in preference to right-angled bends
- Y-junctions should be used in preference to T-junctions
- turning vanes should be used wherever appropriate
- for rectangular ductwork, the aspect ratio should be as close to unity as possible.

Ductwork noise is considered in more detail in sections 2.5.2.3 and 2.6.7 and CIBSE Guide B4 (CIBSE, 2016c).

### Noise

Noise should be prevented from getting through to the occupied spaces. Design features in support of this objective, which largely correspond to those required for energy efficiency, include the following:

- a low air velocity in the ductwork
- the use of round ducts
- the use of bends with large internal radii
- smooth transitions and changes in flow direction
- the use of low-noise control vanes
- low air leakage.

## 2.3.6 Ventilation control systems

### 2.3.6.1 General

Control systems are essential to maintain air quality, thermal comfort and energy efficiency. Increasingly, a wide variety of controls are becoming available that are appropriate for both mechanical and natural ventilation systems. Controls incorporate a variety of sensors and actuators that enable optimum operating conditions to be maintained.

In designing a control system the following should be taken into account.

- Ensure fairness and consistency of control by avoiding occupants being unduly affected by controls from which they do not benefit.
- Provide rapid acting controls that give feedback to occupants to demonstrate response.
- Make sensible decisions with regards to the choice of manual versus automatic control (manual overrides should be provided where practical); any automatic change in state should happen gradually to avoid feelings of discomfort.
- Remove unnecessary complexity by providing controls that are simple and well labelled.

Further guidance on these issues can be found in Bordass *et al.* (1995, 1999).

### 2.3.6.2 Sensors

Typical sensors for automatic control may include:

- CO<sub>2</sub> sensors for occupant generated pollutant
- gas sensors to monitor specific gasses that may be present in a space
- humidity sensors
- passive infra red (PIR) sensors to detect the presence of occupants
- temperature sensors to control thermal comfort and natural cooling

- solar gain sensors for feed forward control to increase ventilation when gains are high.

In addition, sensors for natural ventilation include:

- wind-speed sensors to throttle back vent openings at high wind speeds
- rain sensors to indicate potential driving rain problems
- wind direction sensors to optimise vent opening

### 2.3.6.3 Sensor location

The positioning of sensors to obtain representative readings is very important. Important considerations are outlined below.

#### *CO<sub>2</sub> and gas sensors*

These should be placed to provide a representative value of room space conditions. In a well-mixed mechanically ventilated space sensors may be placed at the extract where they can provide direct feedback to the supply air. It is important not to locate the sensor directly in the breathing zone where a distorted reading can be obtained. Typically a CO<sub>2</sub> sensor might be set at about 1000 ppm. Inevitably some flexibility in operating range must be acceptable such that, for example, this threshold is maintained on average but can be allowed to drift, for example, to 1400 or 1500 ppm. The outdoor concentration needs to be checked and allowance made by setting the threshold proportionately higher if the outdoor concentration is above approximately 400 ppm. Typically 400 ppm is the concentration in open country but it could exceed 500 ppm in city centres.

#### *Temperature sensors*

Internal temperature sensors should not be too close to windows as incoming fresh air may not have mixed with the room air and the sensed condition may not therefore be representative. Again, for mechanical ventilation control, exhaust air temperature should be included in the control loop. External temperature sensors should not be placed on sunny walls that can absorb solar radiation and elevate the sensor reading throughout the 24-hour cycle.

In view of the vertical temperature gradients associated with displacement ventilation systems (see section 2.8.2), the room air temperature sensor is best placed at about head height in a location free from significant draughts.

#### *Humidity sensors*

Humidity sensors and associated controls are typically located in 'wet' zones to control humidity levels and prevent humid air from reaching other parts of a building. They are also used to control humidity levels in air-conditioned buildings where they are linked to humidifiers and dehumidifiers as necessary. This is covered in detail in CIBSE Guide B3 (2016a).

#### *Actuators*

Automatically controlled openings could be modulated, open/shut, have intermediate fixed positions or open in

sequence where a number of vents serve a common zone. Operation should be a function of prevailing weather conditions as well as the required ventilation rate since these will influence the driving forces. Wind speed override may be required to prevent excessive ventilation under windy conditions.

Manual control is the most common form of control. It provides occupants with increased personal control over the environment in their workspace, a factor often associated with increased occupant satisfaction. Control (Willis *et al.*, 1995) should be:

- territorial, positioned locally and, ideally, affect a single person
- intuitive
- accessible.

### 2.3.6.4 Control of volume airflow rate

Volume airflow rate control may be achieved by the following means:

- *Damper*: normally of the butterfly or multi-leaf type and capable of controlling the volume. The main distribution dampers are located to fine balance airflows through legs of the ductwork (assuming that the ductwork has been sized on static regain principles). Typically these dampers are required to provide a pressure drop across the damper of between 50 and 100 Pa. If the pressure drop is higher, there will be a tendency to generate excessive noise, which will require the introduction of a downstream silencer. Normally these dampers are supplied as separate components for direct installation in the ductwork and not as part of an air terminal device. With multiple air terminal devices on a duct leg dampers can also be supplied as integral accessories on the rear of the air terminal device to provide a final terminal balance; typically in this application the dampers provide 10 to 40 Pa pressure drop. Due to the energy inefficiency of damper control, dampers should no longer be used as a primary method of fan duty control. In both applications, final adjustment is carried out manually on-site.
- *Pressure regulating valve*: an assembly consisting of one or two rows of shaped blades, the size of which changes when volume adjustment is required. Because of the particular blade shape, the device gives volume adjustment up to pressure drops of about 600 Pa without generating excessive noise, however a downstream silencer may still be required for a low-noise environment. The majority of dampers are set on-site, but they can be controlled from a static pressure-sensing element. Such units are generally supplied as a separate component for direct installation in the ductwork and not as part of a terminal unit.
- *Mechanical volume controller (air terminal unit)*: a unit that is self-actuating and capable of automatically maintaining a constant pre-set volume flow rate through it independent of upstream duct pressure. The minimum pressure drop across the air terminal unit depending on size varies from 100 to 50 Pa and typically up to a maximum of about 500 Pa. As the supply air pressure increases, most devices of this

type tend to close the airway progressively by means of a butterfly, single or multi-blade damper in the airway. As such an air terminal unit achieves volume reduction by reducing the airway, there is a tendency to generate noise, particularly when working at high air pressures. For this reason, the air terminal unit is generally supplied either with additional acoustic cladding and a separate secondary silencer or the air terminal unit has these features integrated into a single factory-supplied unit. It is factory pre-set to pass a specific volume and, when installed, will automatically give a pre-balanced air distribution system up to and including the air terminal unit. It can be adjusted on-site if required. With the addition of a sensing system and an actuator, this type of air terminal unit can be used for variable volume applications where the flow supplied at the dictates of the sensing system is again independent of upstream duct pressure.

### 2.3.6.5 Control of temperature

This may be achieved by the following means:

- *Blending*: two separate airstreams, one warm and one cool, are supplied to a zone and mixed in a terminal unit to produce a supply air temperature that offsets the zone cooling or heating loads.
- *Reheat*: controlled reheat of a pre-conditioned, low temperature air supply by means of hot water, steam or electric coils, may be used to give a resultant supply air temperature that will satisfy the zone requirement.

### 2.3.6.6 Control options for natural ventilation openings

Control options for natural ventilation openings should be specified with the needs of the occupants in mind. Control mechanisms for natural ventilation opening include the following.

#### *Window/damper actuators*

A number of different actuator types are available for window control. These are electrically driven and include chain, helical cable, piston and rack and pinion type actuators. Because of their linear action, the last two types suffer some disadvantage because they protrude into the space. The actuator will have to cope with the weight of the window and with any wind forces. The use of vertically pivoted windows minimises the effect of the weight of the window but they are less efficient as ventilators. If dampers are used, conventional control mechanisms (pneumatic or electric actuators) can be considered. More details are provided in CIBSE AM10: *Natural ventilation in non-domestic buildings* (2005).

#### *Sensors*

Any automatic control system must be regulated in response to signals from appropriate sensors. Equipment to be specified includes the following:

- *Temperature sensors*: room temperature sensors may be sufficient to indicate excessive ventilation rates because of the influence of ventilation on room

temperature. However this approach will need to be integrated with heating system controls to avoid the two systems fighting each other. Other control parameters may be required as well as temperature.

- *Wind sensors*: wind speed sensors (anemometers) can be used to reduce window opening as wind speeds increase in order to maintain a nominally constant ventilation rate. They may also be used in conjunction with rain sensors to give an indication of potential ingress of driving rain. Wind direction sensors can be used to shut exhaust vents on the windward side of a building and simultaneously open leeward vents in order to avoid back-draughts.
- *Solar sensors*: solar sensors (pyranometers) can be used to indicate periods of high solar gain. The sensor must integrate the gain over a certain period to avoid hunting during periods of patchy cloud.
- *Rain sensors*: windows and vents may need to be closed during periods of rainfall to prevent ingress of water. Typical sensors include the ‘tipping bucket’, which collects rainfall and tips over at a certain level. Each tipping action generates a pulse, the frequency of which can be used to determine the intensity of the rainfall. An alternative approach is to use a device whereby the capacitance changes as the area of moisture on its surface increases. The sensor is heated to dry off the surface when the rain stops.
- *Air-quality sensors*: several approaches to measuring air quality have been used. These usually rely on taking a particular pollutant as indicator for the overall air quality. CO<sub>2</sub> and humidity sensors have been most commonly used; the former in commercial buildings and the latter in residential buildings where condensation is a bigger problem.
- *Occupancy sensors*: infrared sensors that detect movement have been used to identify the presence of occupants and adjust ventilation rates (and lighting etc.) accordingly. Further details on the application of these sensors can be found elsewhere (Oughton and Wilson, 2015).

Air conditioned buildings will have quite complex control mechanisms to ensure optimum operation. When various areas to be air conditioned have differing heat gain patterns with respect to time, these can be met from a central plant in which either the temperature or volume (or both) of the air supplied to each area is varied to meet the particular requirements of the area. Such temperature or volume control may be carried out in ductwork serving a number of rooms or zones, or may be carried out in the terminal units feeding individual rooms. Control strategies include the following.

### 2.3.6.7 Control options for mixed-mode ventilation

In the case of a mixed-mode system, it is also important to remember that the control characteristics of windows differ from the ‘designed’ characteristic of HVAC dampers and coils. The control authority of a window is low and non-linear or proportional, hence the use of sophisticated control algorithms will not bring greater accuracy. Given the pulsing effect of the wind or natural ventilation,

continuously correcting automatic controls should be avoided and the control's response slowed.

The reactions of the occupants to the control systems must also be allowed for in terms of:

- the provision of intuitive user interfaces and control strategies
- adverse reactions to systems that appear to operate in a capricious manner noticeable by changing noise levels or creating a draught
- giving occupants the ability to override automatic controls manually and the impact on system performance
- providing a rapid response to a requested control action.

Elements of the following control sub-strategies may be included:

- *Normal working day control*: where mechanical cooling is switched on when a predetermined temperature is exceeded.
- *Seasonal control*: where, for example, the building is sealed in peak winter and summer conditions under mechanical operation but runs freely during spring and autumn.
- *Top-up/peak lopping control*: where mechanical cooling is switched on only at times of peak load.
- *Pre/post-occupancy space conditioning*: where selected areas prone to overheating may be cooled outside of working hours to ensure that the space temperature is the minimum acceptable at the start of the working day.
- *Overnight cooling*: where the building thermal mass is utilised either through natural or mechanical means, see section 2.4.2.4.
- *Moisture control*: where exposed direct cooling such as chilled ceilings or chilled beams are used.
- *Ventilation control*: where carbon dioxide (CO<sub>2</sub>) sensors are used as a surrogate indicator of occupancy levels to switch on mechanical ventilation when the level exceeds a pre-set value and occupants have not elected to open windows.

### 2.3.6.8 Control of displacement ventilation systems

The main forms of control are as follows.

- *Constant supply air temperature, constant airflow rate*: in which the supply air temperature is maintained at a constant design value selected to be at least 1 K below the required zone mean air temperature. Variations in heat gain will affect the temperature gradient within the space so that, provided the maximum heat gain does not create a temperature gradient in excess of comfort limits, acceptable conditions will be maintained.
- *Constant supply air temperature, variable airflow rate*: the supply airflow rate may be adjusted to accommodate higher variations in heat load and maintain a substantially constant temperature gradient within the occupied zone. This adjustment

can be automatically controlled to maintain a constant difference between the room air temperature and supply air temperature.

- *Variable supply air temperature*: this form of control is not as effective in displacement ventilation systems as it is in mixed-flow systems because the supply air temperature required to maintain an acceptable mean room air temperature is not so directly related to internal heat gains.

Using a control system to maintain substantially constant thermal conditions within a room requires a temperature sensor located in a position that provides a reading that is representative of the occupied zone. In view of the vertical temperature gradients associated with displacement flow, the room air temperature sensor is best placed at about head height in a location free from significant draughts.

### 2.3.6.9 Energy-efficient control of mechanical ventilation systems

Increased system efficiency, i.e. reduced specific fan power, can be achieved by the following measures.

- Select efficient fans (see section 2.6.1).
- Select appropriate attenuation, filtration and heat-recovery devices to reduce system pressure drops (see sections 2.3.3 and 2.3.4).
- Choose appropriate ductwork and system velocities to reduce system pressure drops (see section 2.3.5.3).
- Vary the volume of air through the system, e.g. through the use of two-speed or variable-speed fans (as covered, for example, by Part L of the Building Regulations (NBS, 2013a) for fans rated above 1100 W. This can be achieved through variable speed drives or inlet guide vanes. (The latter technique is not recommended due to its relative inefficiency.) Further information on variable speed fans is available in GIR 41: *Variable Flow Control* (Action Energy, 1996).
- Ensure local extraction by the appropriate location of plant in order to minimise duct runs and hence fan power.
- Use intelligent zoning to avoid the system operating to suit the needs of one small area.
- Switch off systems when they are not in use or not required. Systems may run for longer than intended for a various reasons, e.g. controls may have been overridden and not reset afterwards; automatic controls (e.g. frost thermostats or hidden hardware or software interlocks) may have switched on systems unnecessarily as a consequence of poor setting, calibration or programming. Suitable fault detection should be incorporated, e.g. by reporting the running hours of devices and systems during periods when they are programmed to be off.
- Appropriate coverage of a building by mechanical ventilation, i.e. using natural systems where applicable (mixed-mode approach) (see section 2.3.2.4).
- Control fan operation according to occupancy in both variable and constant volume systems.

- Log hours of operation of systems to identify if systems are operating unintentionally, particularly outside the occupied period. Anticipatory systems (e.g. for optimum start or night cooling) are prone to such behaviour.
- Take care to avoid parasitic loads that may increase energy consumption. Examples include heat-recovery systems that break down unnoticed (or continue to operate when cooling is required); ‘free-cooling’ control systems that introduce the wrong proportions of outside air; and unnecessary heating of air intended for night cooling. Ideally, the performance of such systems should be automatically monitored against the design intentions. Alternatively, systems can be designed deliberately to allow such technical problems to become noticed.
- The supply of air to a space can be controlled by a number of manual or automatic means. The most popular options are:
  - *CO<sub>2</sub> sensing*: useful in buildings where there are wide variations in the ventilation requirement, e.g. bingo halls, cinemas, theatres and meeting rooms
  - *temperature sensing*: useful where it may be advantageous to increase the flow of air when conditions are favourable to take advantage of free cooling
  - *humidity sensing*: fresh air rates can be increased when internal humidity levels are too high, an option used for example in areas where moisture is produced, e.g. kitchens and bathrooms
  - *occupancy sensing*: this enables systems to be switched off when rooms are not occupied.

#### 2.3.6.10 Fire damper control systems

There is a variety of additional systems that give control to fire dampers, either as simple systems to close them on alarm or more sophisticated systems that allow smoke and heat exhaust or area pressurisation. These need to be considered as part of the design process and the latter systems need a very clear cause-and-effect schedule to make sure they achieve what they have been designed to do.

## 2.4 System design

### 2.4.1 Introduction

This section is not intended to provide step-by-step design guidance but to summarise the key issues and performance targets that need to be addressed during design. The guidance contained in this section should be read in conjunction with CIBSE Guides A (2015a) and F (2012). For details of refrigeration methods, see CIBSE Guide B3 (2016a).

System design starts with decision making, taking into account the needs of the occupier and any planning requirements. Energy and environmental impact also play an important part of the decision-making process. A typical

selection approach is presented in Figure 2.26. From this the designer will make a choice between a natural or mechanical system and identify zones that may be suitable for mixed-mode ventilation.

### 2.4.2 Designing for natural ventilation

In the case of natural ventilation important factors relating to the driving forces and the configuration of openings must be considered. Full guidance is given in CIBSE AM10: *Natural ventilation in non-domestic buildings* (2005).

A key issue to consider is the need to take into account all operational regimes—winter and summer, as well as night ventilation and passive cooling if required. Ventilation strategy should be considered on the basis of the whole building rather than just room by room, although each individual room case needs close attention to ensure the efficiency of the proposed design. Circulation areas such as stairwells or corridors can be used as plenums or supply ducts, although care must be taken to avoid these routes acting as ‘short circuits’. Compliance is also needed with fire and smoke regulations as outlined in section 2.5.3.

Consideration must be given to where the fresh air will be brought from (see section 2.6.5), for example it may be beneficial to draw the air from one side of the building to:

- avoid noise and traffic fumes from a busy road
- maximise benefit from wind velocities.

Guidelines for minimising the ingress of external pollution are given in Kukadia and Hall (2011).

The magnitude and pattern of natural air movement through a building depends on the strength and direction of the natural driving forces and the resistance of the flow path as described in section 2.3.2.2.

Fresh air requirements are based on occupant needs (see section 2.2.3) and/or pollutant loads (see section 2.2.2). Airflow rates for cooling will normally be based on a summertime temperature prediction using some form of thermal analysis and also on thermal gains such as from processes and equipment use (see section 2.2.4).

#### 2.4.2.1 The BREEAM requirements for natural ventilation

In addition to the guidelines on natural ventilation, given in section 2.3.2.2, BREEAM (2014) also gives guidance aimed at achieving an excellent environmental rating. A range of supporting guidance documents are being released and the BREEAM website should be consulted. BREEAM is an internationally recognised rating scheme covering the environmental performance of buildings, which sets performance criteria for installed ventilation systems. In the case of the natural ventilation of office-type buildings, the criteria state that: natural ventilation strategy performance must be demonstrated via *either* of the following.

- (a) The openable window area in each occupied space is equivalent to 5 per cent of the gross internal floor area of that room/floor plate. For room/floor plates 7–15 m in depth, the openable window area is on

opposite sides and evenly distributed across the area to promote adequate cross-ventilation.

- (b) The design demonstrates (by calculation, using ventilation design tool types recommended by CIBSE AM10: *Natural ventilation in non-domestic buildings*) that the natural ventilation strategy provides adequate cross flow of air to maintain required thermal comfort conditions and ventilation rates.

For a strategy that does not rely on openable windows, or that has occupied spaces with a plan depth greater than 15 m, the design must demonstrate (by calculation in accordance with requirement (b) above) that the ventilation strategy can provide adequate cross flow of air to maintain

the required thermal comfort conditions and ventilation rates.

2.4.2.2 The design process

The design of a natural ventilation system should take account of the following steps.

- Assess the potential for natural ventilation (see Figure 2.26). Factors include:
  - availability of fresh air
  - minimising problems associated with outdoor noise
  - suitability of building.

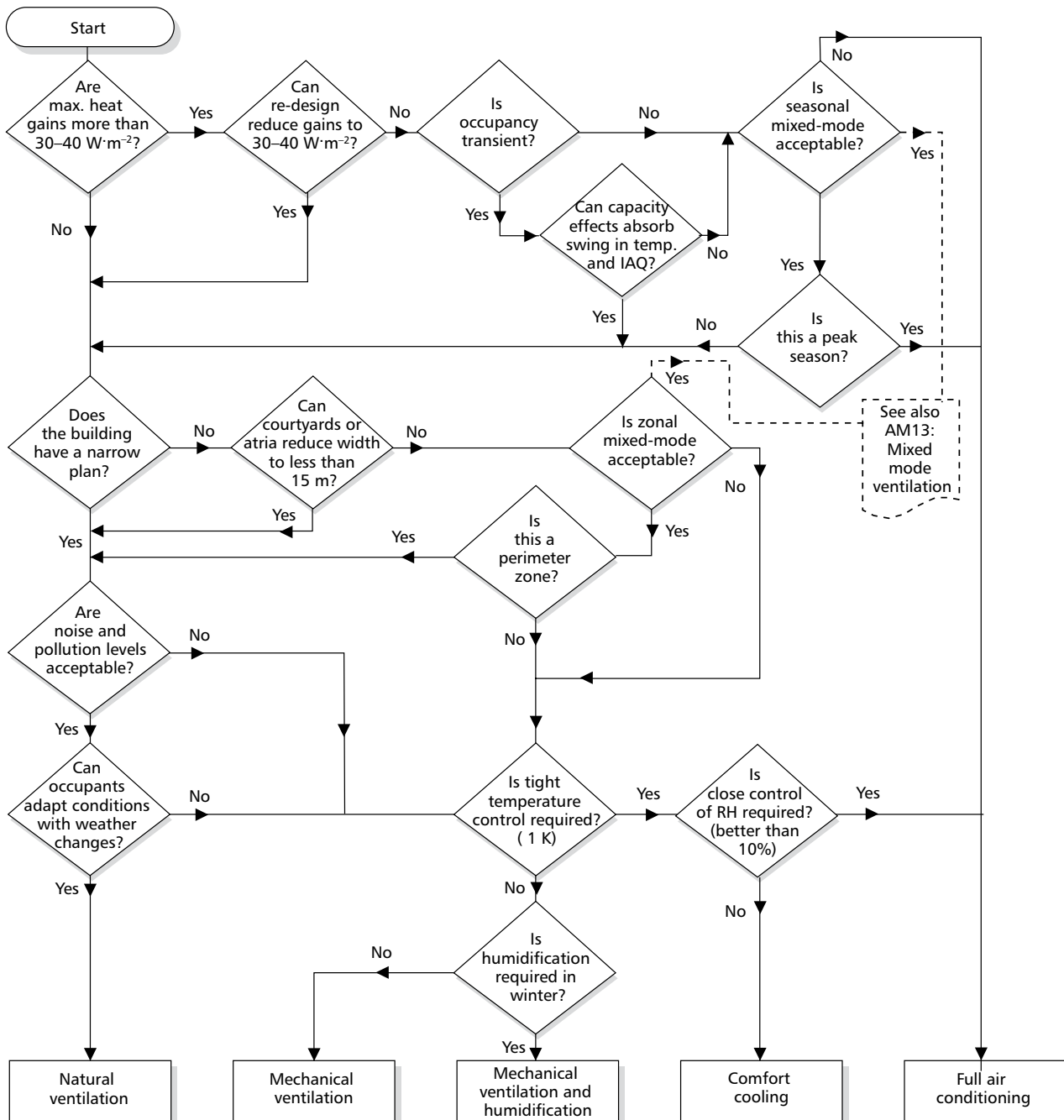

Figure 2.26 Decision-making process (from CIBSE AM10: *Natural ventilation in non-domestic buildings* (2005))

- Determine ventilation rates required for fresh air (see section 2.2.3).
- Determine the requirements for cooling needs (see section 2.2.4).
- Based on local weather data consider the optimum driving forces (wind, stack or combined) for the building.
- From fresh air and cooling need calculate the size and location of openings. Initial estimates can be determined from the calculation equations given in CIBSE Guide A (2015a) and CIBSE AM10: *Natural ventilation in non-domestic buildings* (2005). More detailed analysis using multi-zone, computational fluid dynamics (CFD) modelling or wind tunnel and flume scale modelling may be required for complex buildings (see section 2.4.6).
- Plan the use of windows, vents, passive stacks and wind towers.
- Plan interaction building form, e.g integration with thermal mass (see section 2.4.2.4).
- Identify a control strategy (see section 2.3.6).
- Plan flexibility for future needs including mixed-mode ventilation and mechanical cooling.

#### 2.4.2.3 Meeting thermal comfort and cooling needs

If the internal heat gain rises above approximately 40 W/m<sup>2</sup>, natural ventilation on its own may be inadequate and a strategy involving mechanical assistance may be required (BMI, 1999). Table 2.23 illustrates how the design of the building fabric might be adapted to meet this target (BMI, 1999). However, this table is indicative of a scale only and will vary depending on the characteristics of the particular building and on the freedom or otherwise allowed to the designer to maintain thermal comfort within acceptable limits using these design features. If natural ventilation is to be used for comfort cooling, control of heat gains into the occupied space is a prerequisite. Thus measures must be taken to reduce solar and internal heat gains during warm periods in order to maximise periods of thermal comfort. Advantage needs to be taken of adaptive thermal comfort criteria to enable a temperature spread to be applied.

The ability to open windows to provide increased air movement can provide a beneficial cooling effect in summer (see chapter 1 of CIBSE Guide A (2015a)). However, the high ventilation flow rates associated with summer conditions can cause nuisance draughts that may disturb papers etc. This can be reduced by specifying that the openable part of the window to be above desk height.

The minimisation of draughts is a particular issue for natural ventilation systems in winter. The potential problem can be reduced in a number of ways such as:

- providing multiple trickle ventilators (or similar)
- using specially provided ventilation openings positioned so that the air is warmed before reaching the occupied space (e.g. behind a radiator or in a floor void with a suitable convector heater)
- using a separate natural ventilation system that can pre-heat the air such as a combined weather louvre,

**Table 2.23** Relationship between design features and heat gains

Design features	Total heat gains*/W·m <sup>-2</sup> floor area			
	10	20	30	40
	Minimum room height/m			
	2.5	2.7	2.9	3.1
Controllable window opening (to 10 mm)	Essential	Essential	Essential	Essential
Trickle vents for winter	Essential	Essential	Essential	Essential
Control of indoor air quality	May be required	May be required	Essential	Essential
Design for daylight to reduce gains	May be required	Essential	Essential	Essential
Daylight control of electric lighting	May be required	May be required	Essential	Essential
100% shading from direct sun	May be required	Essential	Essential	Essential
Cooling by daytime ventilation only	Essential	Essential	Problem	Problem
Cooling by day and night ventilation	Not necessary	May be required	Essential	Essential
Exposed thermal mass	Not necessary	Not necessary	Essential	Essential

\* i.e. people + lights + office equipment + solar gain

control insulated damper, heating coil and internal grille system.

It should be recognised that not all parts of a building need to be treated in exactly the same way. Different natural ventilation strategies may be applied to different parts of a building as appropriate.

#### 2.4.2.4 Interaction with building form and fabric

The interaction between building form and ventilation strategy is important. Natural ventilation relies on the building envelope (rather than any mechanical system) to provide the primary environmental control (air quality and thermal comfort). The building form will need to facilitate the airflow strategy. Particular consideration should be given to the following.

- *Building spacing and orientation and their impact on building shading and wind effects:* increasingly this is being analysed by wind tunnel and numerical methods (sections 2.4.6.6 and 2.4.7.8). Some guidance is given in Kukadia and Hall (2011).
- *Planning the width/floor-to-ceiling height ratio to achieve effective ventilation:* as air flows across the zone a sufficiently high 'stratification height' is required to lift heat and contaminants above the downstream occupied space (see CIBSE AM10: *Natural ventilation in non-domestic buildings*).
- *Achieving good solar control by sensible choice of glazing ratios and by shading provision:* buildings with their main façades facing north and south are much easier to protect from excessive solar gain in summer (see CIBSE AM10: *Natural ventilation in non-domestic buildings*). Note that a balance must be achieved in allowing appropriate natural lighting levels.

- *Openings in the external façades to provide airflow paths*: classical single-zone and multi-zone airflow models as well as CFD techniques can assist in optimising opening configurations. These models are discussed in more detail in (section 2.4.6.5 and in CIBSE AM10: *Natural ventilation in non-domestic buildings*). Manufacturers also have a range of programs available to allow review of selection of external, transfer and exhaust units.
- *Use of exposed thermal mass to aid passive and night cooling*: thermal modelling techniques are available to assist design and check with energy performance requirements.
- *Airtightness*: to minimise energy losses and cold draughts in winter and to assist the controllability of natural ventilation.

#### 2.4.2.5 Empirical guidelines for sizing openings and calculating natural ventilation rates

Detailed guidance on calculating driving forces, the size of openings and natural ventilation rates is presented in CIBSE Guide A, chapter 4 (2015a) and CIBSE AM10: *Natural ventilation in non-domestic buildings* (2005).

Some empirical equations for the conditions are available to assist in obtaining approximate guidance on opening sizes. These are taken from BS 5925: 1991: *Code of practice for ventilation principles and designing for natural ventilation* (BSI, 1991). The assumption that ventilation openings can be represented by orifice flow equations (see section 2.4.6) enables the estimation of ventilation rates using standard formulae for simple building layouts. These layouts and associated formulae are shown in Table 2.24 for a simple building with airflow through opposite sides and in Table 2.25 for a situation with openings in one wall only. Both wind-induced and temperature-induced ventilation are given.

The values of area ( $A$ ) used in the formulae should be taken as the minimum cross-sectional area perpendicular to the direction of the airflow passing through the opening.

The formulae given in Table 2.24 illustrate a number of general characteristics of natural ventilation, as follows.

- The effective area of a number of openings combined in parallel, across which the same pressure difference is applied, can be obtained by simple addition.
- The effective area of a number of openings combined in series (across which the same pressure difference is applied) can be obtained by adding the inverse squares of the individual areas and taking the inverse of the square root of the total (see Table 2.24(b)).
- When wind is the dominating mechanism the ventilation rate is proportional to wind speed and to the square root of the difference in pressure coefficient. Thus, although  $\Delta C_d$  may range between 0.1 and 1.0, this will result in a ratio of only about 1 to 3 in the predicted ventilation rates for the same wind speed.
- When stack effect is the dominating mechanism the ventilation rate is proportional to the square

root of both temperature difference and height between upper and lower openings. When wind and stack effect are of the same order of magnitude, their interaction is complicated. However, for the simple case illustrated, the actual rate, to a first approximation, may be taken as equal to the larger of the rates for the two alternative approaches, considered separately. This is shown in Table 2.24(c).

Measurements (Braham *et al.*, 2001) have shown that, with normally sized windows, the magnitude of the resulting single-sided ventilation, while smaller than cross-ventilation with similar areas of opening under comparable conditions, can be large enough to contribute to natural cooling. Table 2.25 provides formulae that enable ventilation rates to be calculated for wind and stack effect. It is suggested that calculations be carried out using both formulae and the larger value taken. The formula for wind-induced infiltration represents a minimum, which will be enhanced up to threefold for certain wind directions and windows with openings that tend to deflect inwards the impinging wind.

#### *Ducted or under-floor pathways*

In order to improve air distribution into deeper spaces, it is possible to use ducted or under-floor ventilation pathways. This can provide ventilation to internal spaces or a perimeter zone local to a pollution source (e.g. a busy road). Because of the low driving pressures with natural ventilation (<10 Pa), it is important to design the supply duct for very low pressure drops. Problems could occur if incoming air is cooled to below the condensation temperature since this will result in condensation in the duct, thus leading to microbiological contamination.

More advanced calculation techniques are available for detailed design and evaluation. These are described in more detail in section 2.4.6 and include:

- zonal models
- CFD
- combined thermal and ventilation models.

A simple design tool and guidance is included in CIBSE AM10: *Natural ventilation in non-domestic buildings* (2005).

#### 2.4.2.6 Other design considerations

##### *Measurement techniques for evaluating natural ventilation systems*

For complex buildings it may be necessary to commission laboratory or other measurement studies to understand flow behaviour. Measurement methods are covered in more detail in section 2.4.7.

##### *Minimising problems associated with outside noise*

Noise from outside sources can present a major problem to natural ventilation designs. Solutions include sound insulation, acoustic vents and the location of openings away from sound sources. These methods are described in more detail in section 2.5.2.

Table 2.24 Standard formulae for estimating airflow rates for simple building layouts (openings on both sides) (reproduced from CIBSE Guide A)

Conditions	Schematic	Equations
(a) Wind only		$Q_w = C_d A_w v_r (\Delta C_p)^{0.5}$ $\frac{1}{A_w^2} = \frac{1}{(A_1 + A_2)^2} + \frac{1}{(A_3 + A_4)^2}$
(b) Temperature difference only		$Q_b = C_d A_b \left( \frac{2 \Delta \theta h_a g}{\bar{\theta} + 273} \right)^{0.5}$ $\frac{1}{A_b^2} = \frac{1}{(A_1 + A_3)^2} + \frac{1}{(A_2 + A_4)^2}$
(c) Wind and temperature difference together		$Q_t = Q_b \text{ for } (v_r / \sqrt{\Delta t}) < 0.26 (A_b / A_w) (h_a / \Delta C_p)^{0.5}$ $Q_t = Q_w \text{ for } (v_r / \sqrt{\Delta t}) > 0.26 (A_b / A_w) (h_a / \Delta C_p)^{0.5}$

Table 2.25 Standard formulae for estimating airflow rates for simple building layouts (openings on one side only) (reproduced from CIBSE Guide A)

Conditions	Schematic	Equations
(a) Wind only		$Q = 0.025 A V_r$
(b) Temperature difference only: two openings		$Q = C_d (A_1 + A_2) \left( \frac{\varepsilon \sqrt{2}}{(1 + \varepsilon)(1 + \varepsilon^2)^{0.5}} \right) \left( \frac{\Delta \theta h_a g}{\bar{\theta} + 273} \right)^{0.5}$ <p>where <math>\varepsilon = (A_1 / A_2)</math></p>
(c) Temperature difference only: one openings		$Q = C_d (A/3) \left( \frac{\Delta \theta h_a g}{\bar{\theta} + 273} \right)^{0.5}$ <p>If opening light is present:</p> $Q = C_d (A \mathcal{F}_\phi / 3) \left( \frac{\Delta \theta h_a g}{\bar{\theta} + 273} \right)^{0.5}$ <p>where <math>\mathcal{F}_\phi</math> is given by Figure 4.15 in CIBSE Guide A (2015a)</p>

External noise should not normally present a significant problem unless opening windows face busy main roads or are within 100 m of a railway line. A partially open window typically has a weighted sound reduction index of 10–15 dB compared with 35–40 dB for thermally insulating double glazing (BSI, 2014b). Measures to improve acoustic performance include:

- the use of acoustic baffles
- siting the opening windows on a quiet side of a building
- the use of acoustic ventilators (as opposed to windows)
- placing buffer zones (e.g. a circulation space) adjacent to the noise source.

As well as the ingress of external noise, consideration also needs to be given to internal acoustic design issues including:

- conflict between partitioning for acoustic privacy and provision of air paths
- that exposed thermal mass increases the number of hard surfaces (see section 2.4.2.4).

Solutions include perforated sound-absorbing tiles and acoustic baffles. Acoustics is dealt with in detail in section 2.5.2.

### *Climate variability*

In both the long and short term, local climate will vary. It is therefore important that the ventilation design takes this into account. In particular, wind and temperature will vary on an hourly basis thus there could be as many as 8760 combinations of driving force in a year. Although rationalisation is possible by taking into account prevailing winds and typical temperature ranges, extreme conditions also need to be considered. Simple calculation methods are useful for performing multiple calculations but they may not have the accuracy of more time-consuming complex methods. Weather sequences must also take into account climate trends.

### *Flexibility*

Flexibility should be provided to cope with changing occupant requirements over the life of the building. Systems can be designed to be capable of relatively simple upgrading (and downgrading) so that extra cooling systems can be added when and where required. Contingency planning is required at the design stage to provide:

- space for any subsequent installation of additional equipment
- sufficient floor-to-soffit height to enable additional servicing to be routed through floor or ceiling voids
- breakout floor zones that could form future service risers.

### *Multiple occupied spaces*

Problems may arise if a single opening is required to provide ventilation for a group of occupants. This can be minimised if the window unit has high- and low-level

openings for independent control by occupants internally and at the perimeter respectively. This may require actuators on the high-level openings operated by a remote controller (that could also be used as part of an automatically controlled night-cooling regime).

Intuitive manual control will not necessarily lead to windows or ventilators being opened at the optimum time of day. The instinctive reaction is to open windows to increase ventilation as indoor temperatures increase later in the day, whereas higher ventilation rates may be more beneficial earlier in the day, when ambient temperatures are lower.

### *Night cooling*

If night cooling is under manual control, windows will either be closed or left open for all the unoccupied hours resulting in either:

- inadequate pre-cooling, with overheating the following afternoon, or
- overcooling, with cold discomfort problems the next day (or a need for heating).

These problems can be avoided by some form of automatic control of window or ventilator opening or by provision of a separate mechanical night ventilation system (see section 2.3.6 on controls).

### *Security*

If a ventilation strategy relies on opening windows (especially if they are left open overnight for night ventilation), particular thought needs to be given to the security implications. Movement of ventilation openings at night and entry of birds through openings can cause problems with movement detection security systems. Stacks and wind-tower configurations, combined with controlled mechanical vents, provide a more satisfactory means for providing night ventilation because they can offer weather and intruder protection and can be kept under a constant control regime

### *Rain*

The large ventilation openings that may be needed to deliver the required airflow should be designed to avoid rain entering the building, taking account of the effects of driving wind, splashing etc.. Particular thought needs to be given to ventilators left unattended during night ventilation.

### *Fire safety*

The ventilation strategy must comply with fire and smoke regulations. More details are presented in section 2.5.3. Solutions include zoning and the use of intumescent vents. See BS 9999: 2008: *Code of practice for fire safety in the design, management and use of buildings* (BSI, 2008a), Part B of the Building Regulations (NBS, 2013g) and RRF50 (TSO, 2005).

## 2.4.3 Mechanical ventilation design

### 2.4.3.1 Introduction

Decisions relating to mechanical ventilation must take into account many aspects including:

- system size (fresh air and recirculation capacities)
- system type (displacement and mixing)
- requirements of individual zones
- room air distribution system design
- location of exhaust terminals
- installation configuration (incorporation of ductwork)
- filtration design
- integration with heating and cooling plant.

These design aspects are summarised in this section.

### 2.4.3.2 System size

Ultimately the system must be sized to meet the fresh air requirements for the intended number of occupants (see section 2.2.3). Also it must be sized (and designed) to ensure that process pollution or pollution from any other sources is maintained at a safe concentration. In a building without mechanical cooling the ventilation system must provide sufficient fresh air ventilation for cooling purposes (see section 2.2.4). Where space heating and cooling is provided by the ventilation system the additional recirculation air also needs to be determined

### 2.4.3.3 System type

An early decision needs to be made about the type of mechanical system. This includes choosing between displacement and mixing ventilation (section 2.2.8) as well as the choice of heating and cooling system.

### 2.4.3.4 Requirements of each zone

Individual zones will need to be separately sized to meet requirements. Plans for adaptation are also necessary to cope with any subsequent redesign of the building layout

### 2.4.3.5 Room air distribution system design

#### *Room air diffusion: criteria for design*

Air diffusion is the main interface between the system and the occupants. If the air diffusion is not well designed the system will fail, no matter how accurately building loads have been modelled and how carefully the plant and equipment have been selected.

The effectiveness of all ventilation and air-conditioning systems depends on the method by which supply air is introduced to, and vitiated air removed from, the space. The parameters that influence the quality of the air at any point in the room are:

- air supply velocity

- temperature differential between the room and supply air
- quality of the supply air
- position of the air supply terminals
- room shape and geometry, including projections
- position, size, and shape of all sources and sinks for heat and contaminants
- temperature of any heat sources and sinks
- rates of evolution and sorption of contaminants
- other factors influencing air movement, such as movement of the occupants and machinery, and air infiltration.

As discussed later, if terminal devices are poorly selected or positioned this can result in draughts, stagnation, poor air quality, inappropriate mixing, large temperature gradients and unwanted noise. The terminal type and layout may be affected by architectural or structural considerations, but conversely particular room air diffusion requirements should form part of the integrated/co-ordinated building design and/or structure (e.g. floor supply).

The occupants' perception of the effectiveness of the system will normally be determined by:

- the velocity of air adjacent to any uncovered or lightly covered skin (e.g. neck and ankles)
- temperature of airstream in relation to that of still air adjacent to other parts of the body
- the level of activity taking place
- the occupants' clothing
- the quality of air in the breathing zone
- the individual's susceptibility and acclimatisation
- the appearance and positioning of any ventilation devices or openings
- the noise emitted.

The above are discussed in detail in section 1.4 of CIBSE Guide A (2015a).

BS EN ISO 7730: 2005 (BSI, 2005a) recommends that, during cooling, the mean air velocity should be less than  $0.25 \text{ m}\cdot\text{s}^{-1}$  for moderate thermal environments with light, mainly sedentary, activity and that, in winter, it should be less than  $0.15 \text{ m}\cdot\text{s}^{-1}$ . No minimum velocity is suggested, although stagnant zones could result in temperature gradients between the ankle and the neck greater than the 3 K recommended. It is likely that sufficient air movement will be generated by other means.

The occupied zone can be defined as a region, the outer limits of which are described by an envelope 1.8 m from the floor and 0.15 m from the walls. However, in the case of low-level supply terminals, the occupied zone is any region where the occupants are likely to linger for significant periods. In the case of desk terminals, this definition does not apply. For desk terminals, mixing occurs over the desk surface and for seatback terminals, mixing occurs in the regions above and between the seats.

An assessment of predicted percentage dissatisfied (PPD) (BSI, 2005a) for a wide range of activity levels, clothing,

body temperatures and velocities shows that, even at low activity levels, velocities as high as  $1.0 \text{ m}\cdot\text{s}^{-1}$  can be acceptable in offsetting high temperatures. This technique has been applied to the concept of spot cooling in some industrial applications (Hwang *et al.*, 1984) whereby heat stress in the workers is avoided by keeping the local conditions below an agreed value of wet-bulb globe temperature.

*Air terminal phenomena*

Many studies of jets and their effect on room air movement have been undertaken. A detailed account and review is presented by Awbi (2003). Figure 2.27 shows the predicted airflow patterns for various types and positions of air terminal device (ASHRAE, 2009).

It should be noted that these patterns are based on stylised terminals. For predictions of air movement appropriate to specific air terminals the manufacturers' data must be consulted. For non-standard situations it may be necessary to model room air movement using a mock up. In many

cases it will be necessary to allow for on-site adjustment of airflow pattern, either during commissioning or operation by the occupant (e.g. desk-mounted terminals).

*Air diffusion terminology*

BS EN 12792 (BSI, 2003) gives definitions and standard terminology used in connection with air movement. Some of the more important parameters are listed below.

*Throw*

A free jet having a given momentum on discharge will establish velocity profiles known as isovels, the shape of which depends on the geometry of the terminal, the temperature of the jet and any other disturbing influences. The velocity decays with increasing distance from the terminal. Throw is defined as the distance from the terminal (measured perpendicular or parallel to the face of the air terminal device depending on the predominant direction of flow) to the  $0.5 \text{ m}\cdot\text{s}^{-1}$  isovel.

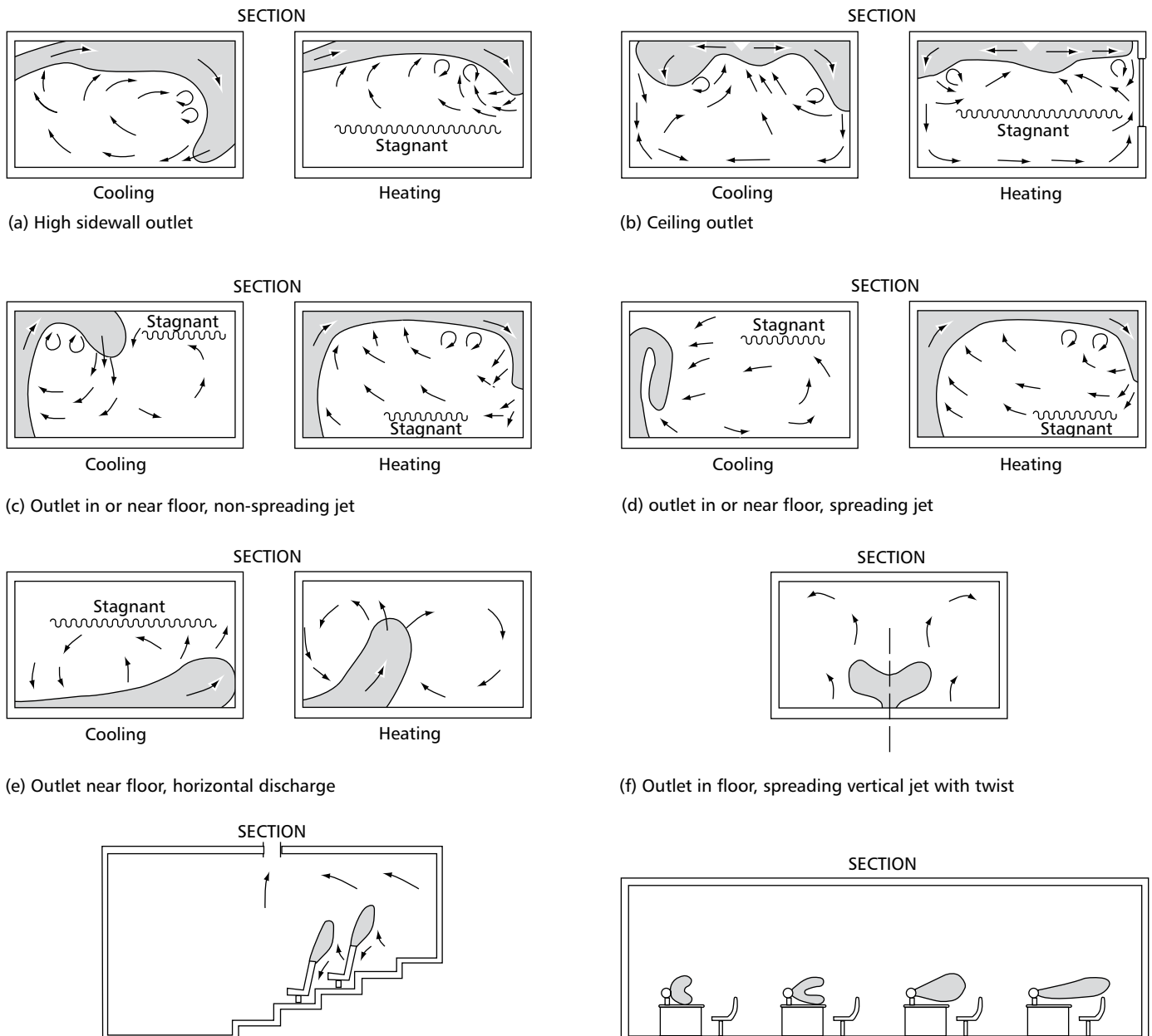

Figure 2.27 Predicted airflow patterns (adapted from ASHRAE, 2009)

Normally lower velocities are required for air entering the occupied zone, typically  $0.25 \text{ m}\cdot\text{s}^{-1}$  for cooling,  $0.15 \text{ m}\cdot\text{s}^{-1}$  for heating. Reference should be made to manufacturers' literature for throw data and recommended mounting distances from solid surfaces and neighbouring terminals.

The maximum throw for an air terminal device depends upon the characteristics of the device, the mounting height and the influence of neighbouring devices.

### Spread

The spread of a horizontal jet is defined as the width of the  $0.5 \text{ m}\cdot\text{s}^{-1}$  isovel. Note that most manufacturers give the width of the  $0.25 \text{ m}\cdot\text{s}^{-1}$  isovel, which is generally of more use to the designer.

### Drop

The drop is defined as the vertical distance from the centre-line of the terminal to the bottom edge of the  $0.25 \text{ m}\cdot\text{s}^{-1}$  isovel.

### Entrainment, mixing and boundaries

Frictional forces cause a momentum transfer to take place between the jet and adjacent room air, which draws the room air in the same direction as the jet. The jet expands with distance from the terminal as it entrains adjacent room air. Hence kinetic energy is expended in creating turbulence, which transfers thermal energy and assists the dilution of contaminants. This process of diffusion may be enhanced by the introduction of a rapidly expanding jet and still further by imparting a swirling motion to the jet.

A jet that is constrained by the walls of a room, such as a full width slot, will entrain less room air and expand more slowly than a free conical jet (Awbi, 2003).

### Effect of temperature differential

Figure 2.27 above shows that a jet that is not influenced by the proximity of a solid surface follows a path that is a function both of velocity and temperature. A warm jet tends to rise until it attaches itself to a horizontal surface, whilst a cold jet falls. Care must be taken to ensure that this does not lead to unacceptable temperature gradients in the occupied zone during heating and excessive air velocities during cooling. The terminal must be mounted such that the  $0.25 \text{ m}\cdot\text{s}^{-1}$  isovel does not enter the occupied zone.

The difference in temperature between the supply and return air may be greater than that between the supply air and the occupied zone, particularly with a low-level supply designed to encourage high-level stratification. This temperature difference is related to sensible heat gain and supply air mass flow, as follows:

$$q_s = m C_{ph} \Delta T \quad (2.15)$$

where  $q_s$  is the total sensible heat gain (kW),  $m$  is the mass flow rate of supply air ( $\text{kg}\cdot\text{s}^{-1}$ ),  $C_{ph}$  is the specific heat of the air and water vapour mixture ( $\text{kJ}\cdot\text{kg}^{-1}\cdot\text{K}^{-1}$ ) and  $\Delta T$  is the room air to supply air temperature differential (K).

Therefore the mass flow rate, and hence the cost of air handling, will depend upon the temperature difference chosen by the designer. This decision will also be influenced by the evaporator temperature and the level of control of humidity. For example, a displacement system with low-level input can supply air at  $18^\circ\text{C}$  with a temperature difference of about 10 K. This can be achieved with high evaporator temperatures and correspondingly low compressor power. However, high-level humidity control will suffer unless the supply air is overcooled and reheated, normally an undesirable combination at peak load. Alternatively, a permanent bypass around the cooling coil can be provided and, if motorised dampers are incorporated at the coil face and in the bypass, part load control supply temperature can be achieved by damper modulation.

For comfort applications, air change rates are unlikely to exceed 10 ACH, corresponding to a cooling temperature differential of 8–12 K. A free horizontal jet from a rectangular grille is likely to create down draughts if providing more than 8 ACH with a cooling temperature differential greater than 8 K.

A maximum cooling differential of 10 K can be applied when either:

- the presence of the Coanda effect (see below) is assured, or
- for a free jet, mixing of supply air with room air outside the occupied zone can be assured without promoting discomfort.

Table 2.26 gives general guidance on the maximum air change rates that can be achieved using various air terminal devices supplying air with a cooling temperature differential of 10 K.

If sufficient mixing between terminal and occupants cannot be guaranteed (e.g. with low-level supply) then the minimum supply temperature of  $18^\circ\text{C}$  applies, with a temperature differential in the occupied zone of 4–5 K. However, the cooling temperature differential is ultimately determined by the maximum exhaust air temperature (Sodec, 1984) (see Table 2.27).

The larger temperature differential indicated for high ceilings is possible due to the smaller influence of ceiling temperature on the mean radiant temperature experienced by the occupants.

Downward discharge is generally only satisfactory for very high air change rates, and hence small temperature differentials, or where room convection is not significant (see below). An exception is the specific case of split air-conditioning systems, where temperature differences can be as high as 20 K. Particular care is therefore needed in their specification, see CIBSE Guide B, Chapter 3 on air conditioning.

High-level supply jets must overcome the buoyancy forces in the room air generated by heat emitters, solar gain, occupants etc., whereas low-level input cultivates these forces to assist the supply jet. For this reason, low-level supply is most satisfactory for applications with high room gains and high ceilings. For low ceilings the radiant heating effect of the ceiling itself may be significant. This may also be a problem where the ceiling void is used as an exhaust air plenum, carrying air heated by air-handling luminaires.

**Table 2.26** Typical maximum air change rates for air terminal devices

Device	Air change rate / h <sup>-1</sup>
Side-wall grilles	8
Linear grilles	10
Slot and linear diffusers	15
Rectangular diffusers	15
Perforated diffusers	15
Circular diffusers	20
Swirl diffusers	20-30

Free descending jets are not recommended for normal use, since the low velocity approaching the occupied zone would cause instability. This could result in localised high velocities due to deflection by convective forces elsewhere in the room (see Figure 2.28). An exception is the case of laminar downflow cleanrooms (BS EN ISO 14644 (BSI, 1999–2013)) where an even velocity across the full area of 0.4 m·s<sup>-1</sup> should be maintained from ceiling to floor. However, even in these circumstances, sources of extremely buoyant upflow should be avoided.

*Coanda effect*

When a jet is discharged from a terminal device adjacent and parallel to an unobstructed flat surface, the jet entrains air from one side only resulting in deflection of the axis of the jet towards the surface. This phenomenon, known as the Coanda effect, is due to frictional losses between the jet and the surface.

The effect diminishes with distance from the terminals as increasing volumes of air are entrained from the room-side of the jet, resulting in a reduction of jet velocity. However, the Coanda effect is maintained despite temperature differences between the jet and the room air. It is a critical factor influencing the selection and positioning of supply air terminals, particularly for rooms with low ceilings, which have little space above the occupied zone in which mixing can occur.

If the Coanda effect is not present the maximum throw for any terminal is reduced by approximately 33 per cent. The main factors that influence whether or not the Coanda effect will occur are:

- the distance between terminal and surface

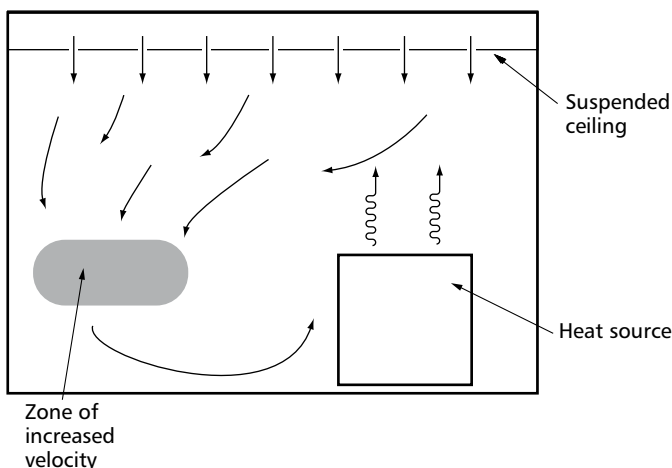

**Figure 2.28** Effect of room convection currents

**Table 2.27** Typical cooling temperature differentials for various applications

Application	Maximum temp. differential / K
High ceiling (large heat gains/ low-level input)	12
Low ceiling (air handling luminaires/low-level input)	10
Low ceiling (downward discharge)	5

- the width of jet exposed to surface
- the velocity of the jet
- the presence of projections and other disturbing influences.

The importance of these influences for side-wall terminals with various aspect ratios, velocities and temperature differences is discussed elsewhere (Awbi, 2003). The most important factor is temperature difference, i.e. buoyancy effects. For the usual range of temperature differences for cooling of 8–12 K, the opening should be within 300 mm of the surface to guarantee attraction. For systems designed to make use of the Coanda effect, provision should be made for on-site adjustment of the jet.

When a jet adheres to a surface, dust particles will be deposited on the surface leading to staining, hence supply air cleanliness is of paramount importance. Cleanliness of the exhaust air is difficult to control and some staining of surfaces near to exhaust openings is inevitable.

Techniques exist (Awbi, 2003) for predicting the influence of projections, such as downstand beams and surface-mounted luminaires, on a jet flowing across an otherwise smooth surface. An obstruction may cause the jet to separate completely from the surface, hence destroying the Coanda effect, or it may separate and join some distance downstream of the obstruction.

The critical distances at which these phenomena are likely to occur depend on the depth and shape of the obstruction and size of the supply opening. The influence of supply air to room air temperature differential is small but depends upon the extent to which mixing has occurred before the jet meets the obstruction.

Figure 2.29 shows the effect of a horizontal surface on a jet rising close to the vertical surface. The Coanda effect is maintained after the change in direction provided that the velocity is adequate, particularly in the case of cooling jets, and that the temperature differential between supply and room air is not too large. Guidance for selecting optimum supply velocities and temperature is given elsewhere (Awbi, 2003).

*Interaction between jets*

Figure 2.30(a) shows possible room air velocity patterns for two jets directed towards each other along a 3 m high ceiling. The individual velocities of the two airstreams must not be greater than 0.25 m·s<sup>-1</sup> at the boundary otherwise discomfort may occur due to excessive draughts.

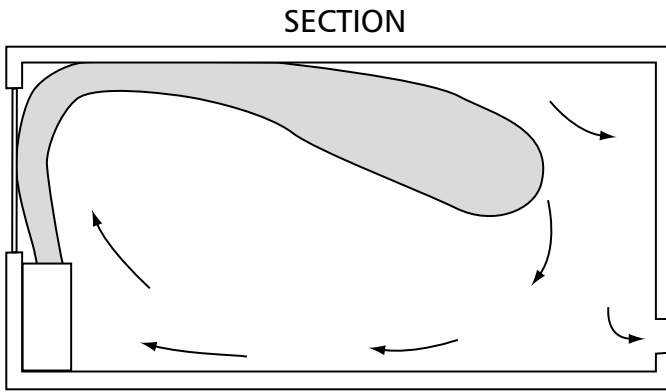

Figure 2.29 Effect of horizontal surface on a jet

The envelopes of two converging jets may also interfere with each other, combining to form a single, wide jet with a maximum velocity at the new axis between the two jets (see Figure 2.30(b)). A similar phenomenon occurs with two jets moving in tandem (see Figure 2.30(c)). The downstream jet entrains and accelerates the decaying upstream jet and forms a wider jet with an axis further from the neighbouring surface. The cumulative effect of a series of single-way jets can result in a deep jet that intrudes into the occupied zone resulting in unacceptably high room velocities.

Figure 2.31 shows examples of possible layouts for ceiling diffusers. The main problems likely to be encountered are those described above. Down-draughts may be encountered in areas marked 'X' and this problem may be eliminated by avoiding terminals with excessive throw, particularly in large spaces where stagnation between terminals is unlikely to occur. The layout shown in Figure 2.30(c) may cause convergence problems with long rooms.

For side-wall applications, the spacing of diffusers should be in accordance with manufacturers' recommendations. However, in the absence of such recommendations, Table 2.28 may be used in conjunction with throw and deflection data to determine the diffuser spacing. For a terminal mounted close to a wall, spacing should be halved to give the minimum distance from the centreline to the wall. Table 2.29 (Sodec, 1984) indicates typical turndown limits for various types of fixed air terminal device.

**2.4.3.6 Location of exhaust terminals**

The positioning of the opening has little influence on the airflow pattern in the space because the zone of localised high velocities associated with exhaust openings is very close to the opening.

Exhaust terminals may be sited to advantage:

- in a stagnant zone where supply jet influence is limited
- close to a source of unwanted heat and/or contamination, e.g. above a luminaire
- close to an excessively cold surface to increase its surface temperature and thereby reduce radiant losses and cold draughts
- at a point of local low pressure, e.g. the centre of a ceiling diffuser.

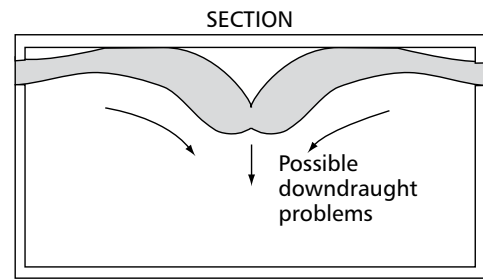

(a) Opposing jets

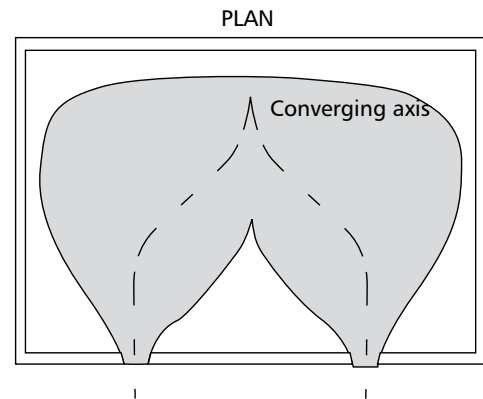

(b) Converging jets

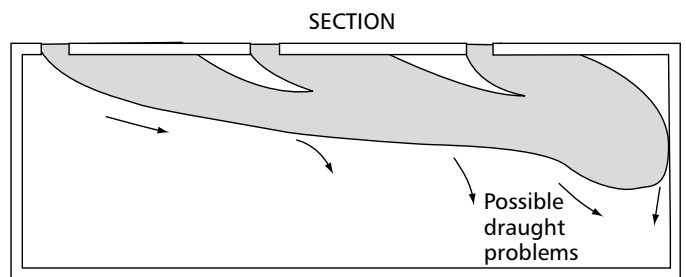

(c) Three jets in series

Figure 2.30 Room air velocity patterns; interaction between jets

Positions that should be avoided are:

- within the zone of influence of a supply air terminal since this allows conditioned air to pass directly to exhaust without first having exchanged heat with its surroundings; this results in very low ventilation efficiency
- close to a door or aperture that is frequently opened since this leads to the exhaust handling air from outside the conditioned space
- in a position that causes contaminated room air to be drawn through the occupants' breathing zone.

**2.4.3.7 Installation configuration: incorporation of ductwork**

Considerations of layout are discussed in section 2.3.5.2. Ductwork is covered more generally in sections 2.3.5, 2.4.5 and 2.6.7.

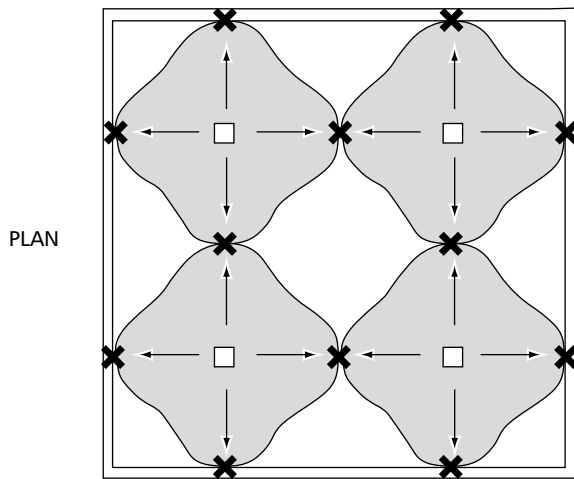

(a) Four-way ceiling diffusers, symmetrical layout

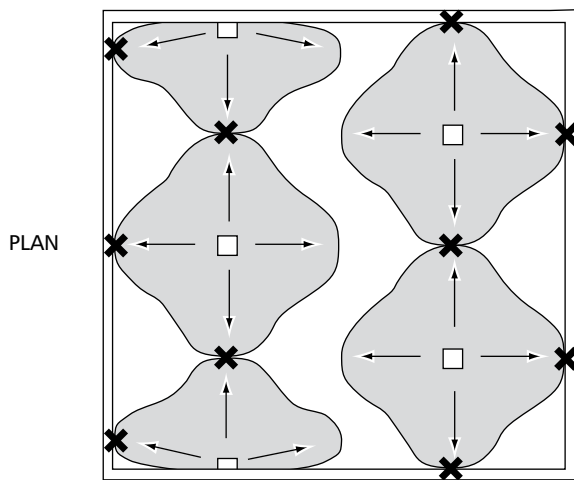

(b) Four-way ceiling diffusers, off-set layout

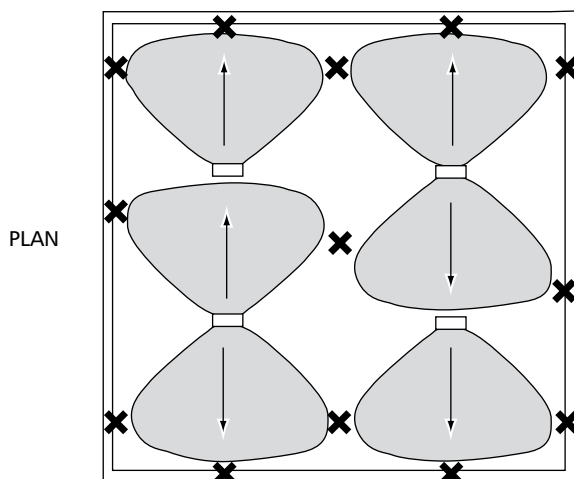

(c) One and two-way ceiling diffusers, contra-flow layout

**Figure 2.31** Supply terminal layouts for open plan spaces

Further information on spatial allowance for ductwork is available from Design and Maintenance Guide 08: *Space requirements for plant access, operation and maintenance* (DEO, 1996), BSRIA TN 10/92: *Spatial Allowances for Building Services Distribution Systems* (1992) and BS 8313: 1997: *Code of practice for accommodation of building services in ducts* (BSI, 1997).

**Table 2.28** Data for determining spacing of ceiling diffusers

Deflection / deg.	Spacing / m	
0	$0.20 L_x$	$0.33 L_y$
22.5	$0.25 L_x$	$0.50 L_y$
45	$0.30 L_x$	$1.0 L_y$

Note:  $L_x$  = throw (m) where axial velocity has decayed to  $0.25 \text{ m}\cdot\text{s}^{-1}$ ;  
 $L_y$  = throw (m) where axial velocity has decayed to  $0.5 \text{ m}\cdot\text{s}^{-1}$

**Table 2.29** Turndown limits for types of fixed air terminal device (Sodec, 1984)

Type of outlet	Maximum turndown/%
Ceiling mounted:	
— not using Coanda effect	50
— using Coanda effect	40
Floor mounted outlets:	
— perforated plate and fixed bar grille	60
— free jet outlets	50
— outlets with swirl	40
Desk outlets:	
— linear type	50
— ball type	50
— outlets with swirl	40

## 2.4.4 Mixed-mode ventilation design

### 2.4.4.1 Introduction

Mixed-mode ventilation will incorporate both natural and mechanical design requirements and therefore it is important to refer to the previous two sections. In the case of the mixed-mode approach, however, dominance often falls on natural ventilation with the mechanical systems being as simplified as possible. In the design of a mixed-mode system the issues described in this section also need to be considered.

### 2.4.4.2 General design issues

The range of circumstances encompassed by the term 'mixed-mode' system is extremely broad. It encompasses, for example, a building that is almost entirely naturally ventilated except for areas of high heat or moisture production served by mechanical systems, to one that is entirely served by air conditioning with the intention that this might in the future be converted to natural ventilation. Hence the guidance provided here must be considered in the light of the specific strategy, or its derivative, as determined in section 2.3.2.4. Furthermore, this section cannot be treated in isolation but read in conjunction with sections 2.4.2, 2.4.3 and CIBSE Guide B3 (CIBSE, 2016a), which consider the principles of the individual operating modes.

### Building fabric

Mixed-mode is a term describing servicing systems that combine natural ventilation with any combination of mechanical ventilation, cooling or humidification in a strategic manner. In common with buildings that are solely naturally ventilated, this approach requires that benefit be obtained from the building fabric.

The presence of mechanical systems means that a balance needs to be drawn, using value engineering principles, between investment in the relatively long-lived fabric and expenditure on the shorter-lived (and easier to modify/replace) building services, components of which can subsequently be added when and where necessary.

Although the building services in a mixed-mode system should usually cost less than in a fully mechanically serviced building, some additional investment may be needed to improve their efficiency, responsiveness, control and adaptability. The initial cost of the mechanical services and the openable windows or vents combined can be greater than that for a sealed building.

Obviously, the greatest economies are made if the improvements to the fabric allow the building services system to be completely eliminated from part or all of the building. For example, reducing fabric and internal heat gains may allow mechanical cooling to be avoided. A highly insulated and airtight fabric with low-powered mechanical ventilation (and heat recovery) may allow both mechanical refrigeration and perimeter heating to be avoided. The effective use of external night-time temperature differentials can permit any excess heat built up during the day to be removed at night, using natural and/or mechanical ventilation, thereby reducing or eliminating the need for mechanical cooling during the daytime (see 'Night cooling' in section 2.4.2.6) and see CIBSE Guide B, Chapter 3 on air conditioning.

In the particular case of zoned systems, a consideration may be to introduce 'localised' fabric enhancements to reduce heat gain, e.g. additional treatment of the roof fabric to ameliorate solar heat gains or additional solar shading of selected windows. A further option might be to introduce 'assisted passive' measures before employing full mechanical systems. This might take the form of a fan in selected natural ventilation 'stacks' for use under peak conditions or on days when inadequate external forces are available or possibly simple desk fans.

#### *Combining natural and mechanical systems effectively*

Within complementary systems, the balance between the operation of the natural and mechanical system elements needs to be optimised. This requires a 'trade off' between the extent of passive and active features, for example the number and location of the openable windows will depend upon the extent of mechanical ventilation. The processes by which this balance can be achieved are given in CIBSE AM13: *Mixed mode ventilation* (2000a).

In the case of zoned systems, it requires an understanding of the problem areas that will require mechanical assistance. These might include:

- zones facing inferior environmental conditions, such as top floors, corner rooms, internal areas, areas local to non-openable façades, or areas where partitioning inhibits bulk air movements
- toilet areas
- areas where heat- or odour-producing equipment is located such as areas containing photocopiers or drinks machines, tea rooms or cleaners' cupboards
- restaurants or kitchens

- areas with dense occupation or high equipment heat loads that may require comfort cooling or close-control air conditioning such as meeting rooms, electronic data processing rooms, dealer rooms etc.
- atria.

#### *Flexibility*

Flexibility is of particular concern with contingency systems where future change is taken into account. This requires the provision of a building fabric with a stated indoor environment control performance and a defined strategy for subsequent adaptation through the addition and omission of either centralised or localised supplementary mechanical systems. The extent to which systems are initially installed, or allowance made for them, will depend upon the context but the decision must be taken in the light of the ease and speed of subsequent installation and the likely extent of upgrades, sub-tenancies, or critical areas.

#### *Plant rooms*

It may be possible to include space for plant rooms that can be put to alternate use until it is required for ventilation or cooling purposes, for example as storage or car parking. External flat roof and undercroft locations may also be suitable. Plant room locations should preferably allow mechanical plant containers to be installed. A further option is prefabricated plant rooms that can be obtained on hire and 'plugged in' with minimum site disruption. These can subsequently be disconnected for reuse elsewhere when a tenancy terminates.

#### *Distribution routes*

The availability of space for routing services to and around individual rooms often determines the overall level of flexibility. The recommended heights of exposed ceiling soffit slabs to facilitate natural ventilation can often provide adequate space for a future suspended ceiling void or bulkhead, capable of accommodating a wide range of HVAC systems. A suspended floor may also allow direct expansion, chilled water and condensate pipes to be routed to any potential 'hotspot'. With appropriate initial sizing the floor void also has the potential to become a floor supply plenum, from which rooms or larger areas can be supplied with air.

It is important to ensure continuity of the routes between the various parts of the system. A clear route without constrictions is needed from the spaces designated for main plant, via the risers, to the tertiary run-outs. Care should be taken to avoid inadequate space for connection between risers and the floors they are to serve.

Room must be given for the installation of fire dampers at compartment boundaries. This should also allow for access for maintenance. See notes on fire safety in 'Fire issues' in section 2.3.5.2 if fire doors are to be used as part of the route.

#### *Choice of HVAC system*

The choice of HVAC system will depend upon the client's functional requirements (see section 2.2.1). In the case of

zoned or contingency systems the choice between freestanding or centralised systems is dependent upon:

- the size and distribution of the zones to be treated
- planning restrictions on the use of the façade
- the availability of space for logical horizontal and vertical distribution routes.

#### 2.4.4.3 Energy-efficient operation of mixed-mode systems

The principles for achieving energy-efficient operation in mixed-mode systems are a combination of those applied to buildings operating in either natural or mechanical ventilation modes. Prioritisation of these principles depends upon the extent to which mechanical systems for ventilation, cooling or humidification have been installed.

Additionally, consideration needs to be given to the following points.

- Mechanical systems should be used only when and where required. The specific fan power increases with air change rate. Furthermore, as the air change rate increases, the occupants are more likely to notice the difference between when the system is operating and when it is not. This may reinforce the tendency for it to be left running unnecessarily. The use of zoned mixed-mode systems helps to overcome the need for whole systems having to operate in order to service small demands.
- Natural and mechanical systems should not conflict in their operation, e.g. mechanical systems competing with air coming in through the windows, or simultaneous humidification and dehumidification. Such situations can be reduced through making users aware of the rationale behind the operation of the system and having suitable trigger points for changeover operation. The state and performance of the system should be monitored and system conflicts reported.
- Systems should not default to a non-optimal state, e.g. switched on when they could be switched off or, at least, operating at reduced output. This risk can be minimised by avoiding over-complex design.

#### 2.4.4.4 Control

The control strategy for mixed-mode systems is context dependent, but aims overall for energy-efficient operation, maximum staff satisfaction and ease of building management. This is achieved through:

- maximisation of the natural operating mode
- integration of natural and mechanical systems to avoid system conflicts, wasteful operation and discomfort
- simple and effective control for occupants that is non-presumptive
- simple and effective controls for the building management that are easy to commission and operate on occupation of the building.

The general principles of a good control strategy are given in section 2.3.6.

#### 2.4.4.5 Performance assessment

Some aspects of mixed-mode design may be difficult to resolve or to optimise using normal calculation methods and rules of thumb. More detailed simulation may be desirable in:

- appraising options
- developing new concepts and testing their robustness under all foreseeable conditions
- demonstrating the capabilities of an option to clients
- refining a chosen approach.

Appendix 2.A6 considers the techniques of dynamic thermal simulation and air movement analysis. In applying them specifically to mixed-mode systems the designer must consider:

- the full variety of potential (often overlapping) operational modes and control variables
- the trigger points for each control strategy element
- the potential actions of occupants
- uncertainty concerning the actual operation of the building compared with the intent and the consequent robustness of the solution
- possible differences between parts of the building and areas of particularly demanding localised conditions that place particular demands on the ventilation system
- possible adverse interactions between adjacent zones in different operating modes
- possible adverse effects of facilities designed for one mode and operating in another, e.g. facilities designed for summertime ventilation and cooling may not work well in cold weather, possibly leading to draughts or excessive heat losses.

The selection of appropriate weather data and treatment of heavyweight buildings within thermal models is discussed in Appendix 2.A6.

#### 2.4.5 Ductwork principles of design

##### 2.4.5.1 General

General background information on this topic is provided in section 2.3.5.2. Design is concerned with duct layout, sizing minimising pressure loss and fire safety. For further fire safety information see section 2.5.3.3.

##### 2.4.5.2 Duct layout

In most installations, the constraints imposed by the building or other structures (e.g. single or multiple plant rooms, split systems based on tenancy arrangements etc.), and the siting of fans, plant items and terminals, can lead to the adoption of an overall duct layout that is not ideal. Room must be given for the installation of fire dampers at compartment boundaries. This should also allow for access for maintenance

Considerations of duct layout design are discussed in detail section 3.5.2.

### 2.4.5.3 Spatial requirements

Provision of sufficient space for ductwork is essential and must be addressed at an early stage in the design process of the building.

Laying out the space required for ductwork is, to an extent, an amalgam of experience, skill and three-dimensional visualisation. Adequate space must be provided for installation and maintenance of the ductwork and associated equipment such as fire dampers at compartment boundaries. The designer should ensure that ductwork is co-ordinated with the other engineering services to be accommodated in the same space, particularly in false ceiling voids and riser spaces where there may be several distribution systems vying for restricted space. Developments in building information modelling (BIM) (ASHRAE, 2013) should be considered for this type of task.

Branches from vertical risers to serve horizontal distribution routes should be considered with care, as this is likely to be the most congested area of the service core. If the service core is enclosed on three sides (e.g. by a lift shaft and an external wall) the horizontal distribution from the core will be extremely difficult, with little space for installation and maintenance.

The area served by a single riser will dictate the size of the horizontal branch duct. The depth selected for a branch duct will have a significant influence on the false ceiling or raised floor depth. It will also affect the overall floor-to-floor heights and hence have significant influence on building costs.

The depth of the horizontal element is a function of the number of vertical risers, generally:

- maximum number of vertical risers equates to minimum horizontal element depth
- minimum number of vertical risers equates to maximum horizontal element depth.

Adequate space must be allowed around ducts for fitting of insulation, hangers and supports during installation and for access during subsequent maintenance. Access will also be dependent on the clearance from adjacent objects such as structural items and the type of jointing method.

Suitable allowances are given in Appendix 2.A2, which also shows examples of common problems associated with ductwork access.

Ductwork clearances can be reduced with care, providing jointing, insulation and maintenance of any vapour barrier is achieved. Consideration should also be given to how the ductwork will be tested and how it will eventually be replaced.

Adequate space shall be allowed at compartment boundaries for the installation of fire dampers using a tested installation method. The fire damper installation method to be used should be clearly defined as part of the ductwork/supporting construction design, so that it meets the fire classification of the boundary

Further information on spatial allowance for ductwork is available from Design and Maintenance Guide 08: *Space requirements for plant access, operation and maintenance* (DEO, 1996), BSRIA TN 10/92: *Spatial Allowances for Building Services Distribution Systems* (1992) and BS 8313: 1997: *Code of practice for accommodation of building services in ducts* (BSI, 1997).

### 2.4.5.4 Interaction with structure and building form

Because ductwork is likely to be the most space-intensive service provided, it is important that the ductwork design is fully co-ordinated with the design of the building structure to minimise the number of bends and other fittings, each of which will increase the resistance to airflow. This is particularly important for new installations where requirements apply to maximum fan power levels. The structural design may have reached beyond an outline design and shape by the time that ductwork design commences.

Provided they are allowed for early in the design, it is usually possible to accommodate vertical ducts of any desired size without great difficulty from both structural and planning viewpoints. Horizontal ducts present more problems; if they are located between floors, headroom will be restricted and there will be limits on the floor area that a horizontal duct can serve. Early checks should be carried out to ensure that the vertical main ducts enable horizontal distribution without compromising the performance of the installation or the available headroom and that structural members allow branch ducts to leave the main ducts.

Distribution of the engineering services within a building are likely to follow a pattern associated with the main building circulation route that represents the main functional pattern of the building. This may not be the most efficient route for the ductwork. The large space requirements for ductwork mean that it can be desirable to locate plant close to the areas they serve.

This should include space to fit fire dampers that are suitable to any supporting construction used. The requirements of Part B of the Building Regulations (NBS, 2013g) should be followed. Details of fire damper installation methods are given in DW/145: *Guide to Good Practice for the Installation of Fire and Smoke Dampers* (BESA, 2010) and *Fire Dampers (European Standards)* ('the ASFP Grey Book') (ASFP, 2010).

Sufficient space needs to be provided for ease of fitting the ductwork. Providing access for maintenance is also important since it will be expensive to install retrospectively, whether ducts are horizontal or vertical. Space should also be allowed for additions and alterations.

Co-ordination of the engineering services should ensure that the area for removal of access panels and covers and entry into the ductwork is free of services and readily accessible without obstructions.

### 2.4.5.5 Duct sizing

#### Background

Duct sizing and pressure loss calculations are normally carried out as a combined exercise to quantify the ductwork dimensions and provide data for specifying the fan duty. The duct sizing process and pressure loss calculations require the specification of system requirements, including:

- system type, i.e. low, medium, high pressure or industrial
- volume flow rates in all parts of the ductwork
- positions of fans, other plant items, supply-and-extract terminals
- special operating requirements, e.g. minimum conveying velocities in extract systems
- ductwork type, i.e. circular, rectangular, flat oval
- layout of the duct runs, including fittings, dampers and plant items
- duct material.

The purpose of duct sizing is (*i*) to determine the cross-sectional dimensions of the various parts of the duct system, and (*ii*) to ensure a balanced system that delivers design conditions. Furthermore the system, fans and other plant items should be:

- economical in installed and operating costs
- compatible with the space limitations imposed by the structure and other services
- sufficiently quiet in operation
- easily regulated after installation to achieve the design airflow at each terminal.

In practice, duct sizing seeks to obtain an economical and practical solution to these objectives by either simplified manual procedures or computer programs. The computer programs can vary in complexity from computerisation of manual procedures to overall design including optimisation, damper settings and noise assessment.

Before commencing duct sizing, a schematic of the air distribution system must be prepared. This should indicate the airflow directions and contain the following information:

- system identification for each section
- air volume flow rates in each section
- the length of all straight sections
- descriptions of fittings, dampers, plant items and terminals.

An example schematic is shown in Figure 2.32.

#### Approximate sizing

Because ductwork can be large, it will often be necessary to assess the size of individual ductwork in critical locations, particularly where horizontal branches leave the main vertical risers. It is often possible to adjust the size of the vertical space well into the detailed design. Horizontal

branches, however, cannot encroach on the necessary headroom.

To make a preliminary estimate of a branch size, calculate the airflow rate required in the area served by multiplying the zone volume by the number of air changes per hour and divide by 3600 to obtain the zone flow rate in  $\text{m}^3\text{s}^{-1}$ . Two air changes an hour may be appropriate for offices with a separate heating system for fabric losses. Where the air is used for heating, four air changes an hour may be required or six air changes or more for an air-conditioned space. Dividing this flow rate by the velocity given in Tables 2.16 and 2.17 gives the duct cross-sectional area required. For conventional systems, the aspect ratio (long side to short side) of rectangular ducting should not exceed 3:1.

#### Manual duct sizing method

Simple design methods include:

- velocity method
- constant pressure drop (or equal friction loss) method
- static regain method.

The most common method is based on delivering constant pressure drop per unit length for a duct run, with maximum duct velocities as set out in Tables 2.16 and 2.17 for low-, medium- and high-pressure systems.

These methods are simple procedures that use ductwork data charts to determine duct dimensions. The overall cost effectiveness, ease of system regulation and noise can be taken into account by imposing limits on some of the design parameters. It is recommended that the calculated duct size is rounded to the nearest recommended duct size (see Appendix 2.A1) before the pressure drop calculations are carried out. A brief description of these methods is given below.

#### Velocity method

This method is based on the selection of duct velocities by the designer using limiting noise generation and/or pressure drop. In a typical system the velocity at the fan connection is chosen and velocities are also chosen for subsequent duct runs with the aim of progressively reducing velocities from the fan to the terminals. Tables 2.16 and 2.17 give some guidance on suitable maximum air velocities. In practice, this is only used on simple layouts or sections of systems, as the procedure depends on experienced but subjective judgements. It is difficult to produce a coherent selection of sizes for a complex layout on this basis. In industrial systems where minimum transport velocities are required this method may be employed more frequently.

#### Constant pressure drop (equal friction loss) method

The basis for this method is to select a constant pressure loss per unit length for the duct runs and then to size the ducts at this rate using Figure 2.33 below. This method is used for sizing very simple low-pressure supply-and-extract systems, some medium-pressure systems and also for VAV systems. For low-pressure systems, typical values used for the constant pressure loss rate are in the range  $0.8\text{--}1.2 \text{ Pa}\cdot\text{m}^{-1}$  with duct velocities not exceeding  $10 \text{ m}\cdot\text{s}^{-1}$ . At large volume

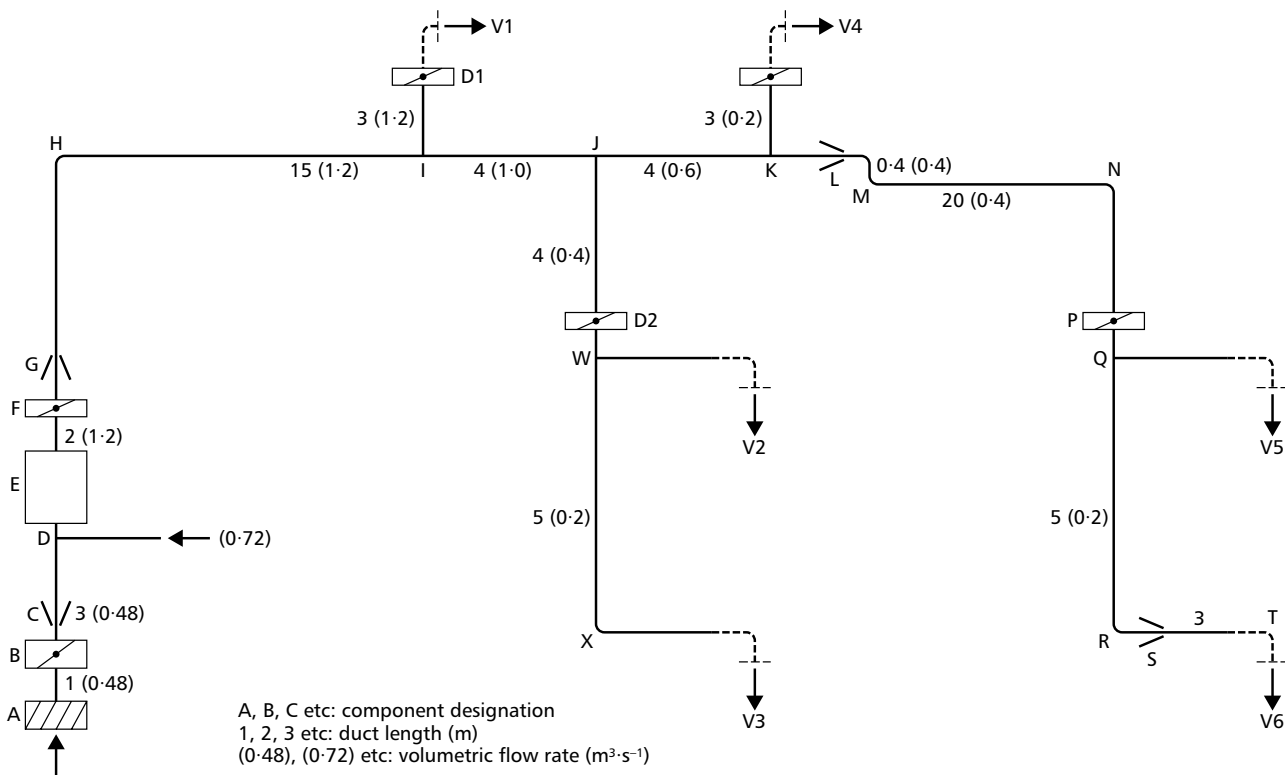

Figure 2.32 Example schematic of ductwork layout, showing lengths (m) and flow rates ( $\text{m}^3\cdot\text{s}^{-1}$ ) (see Appendix 2.A5 for calculation procedure)

flow rates in low-pressure systems the  $10 \text{ m}\cdot\text{s}^{-1}$  duct velocity limit should override the constant pressure loss rate chosen, leading to somewhat lower pressure loss rates in the large ducts.

The sizing process involves:

- the selection and use of a vertical constant pressure loss line in Figure 2.33, appropriate to the design requirement
- reading off the circular duct diameter for the actual volume flow rate
- if a rectangular or flat oval duct is required, taking the dimensions from Tables 2.A1.1 or 2.A1.2 (see Appendix 2.A1), as appropriate, for the equivalent circular diameter.

The friction loss method gives a reducing velocity from the fan to the terminals. Adopting different pressure loss rates for the individual branches of a system can be used to produce a more nearly equal resistance to each duct run and so assist balancing the system. This modification can be introduced during the pressure loss calculation.

Initially, all parts of the system should be sized to the same pressure loss rate and the adjustments to individual branch sizes only carried out after the pressure losses in the initial system design have been computed. These adjustments are most quickly and conveniently carried out by computer.

*Static regain method*

When the velocity in a duct is reduced without excessive losses occurring, the static pressure increases. In high-pressure systems, this increase can be significant and is the basis for the static regain duct-sizing method. The principle

is to size ducts between branch take-offs so that the recovery in static pressure after one branch take-off due to reduction in velocity is equal to the static pressure loss due to friction and fittings in the subsequent duct run. The method seeks to equalise the static pressures at the branch take-offs, and where these take-offs serve high-pressure terminals an inherently balanced system can be achieved.

The static regain method is used primarily for those parts of a high-pressure system where the initial duct velocity pressure is sufficient to give static pressure regain without unnecessarily low duct velocities at the end of the run. In practice, only the duct mains serving multiple terminal branches are sized by this method, while the smaller branches to terminals are sized by the equal friction method (see ‘Constant pressure drop (equal friction loss) method’ above) to minimise their size and cost. High-pressure terminals on the same system normally all have roughly the same pressure loss. If this value is high compared with the branch duct pressure loss, then variations in the latter between different branches arising from the use of the equal friction sizing method will not significantly unbalance the system. The static regain method uses duct static pressure losses rather than total pressure losses in the sizing procedure.

The static regain is due to the drop in velocity pressure. However it must be emphasised that there is still a drop in total pressure  $\Delta p_t$ , due to friction. For the branch shown in Figure 2.34, subscript ‘c’ denotes ‘combined’ flow, subscript ‘b’ denotes ‘branch’ flow and subscript ‘s’ denotes ‘straight’ flow.

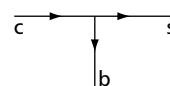

Figure 2.34 Schematic of duct branch

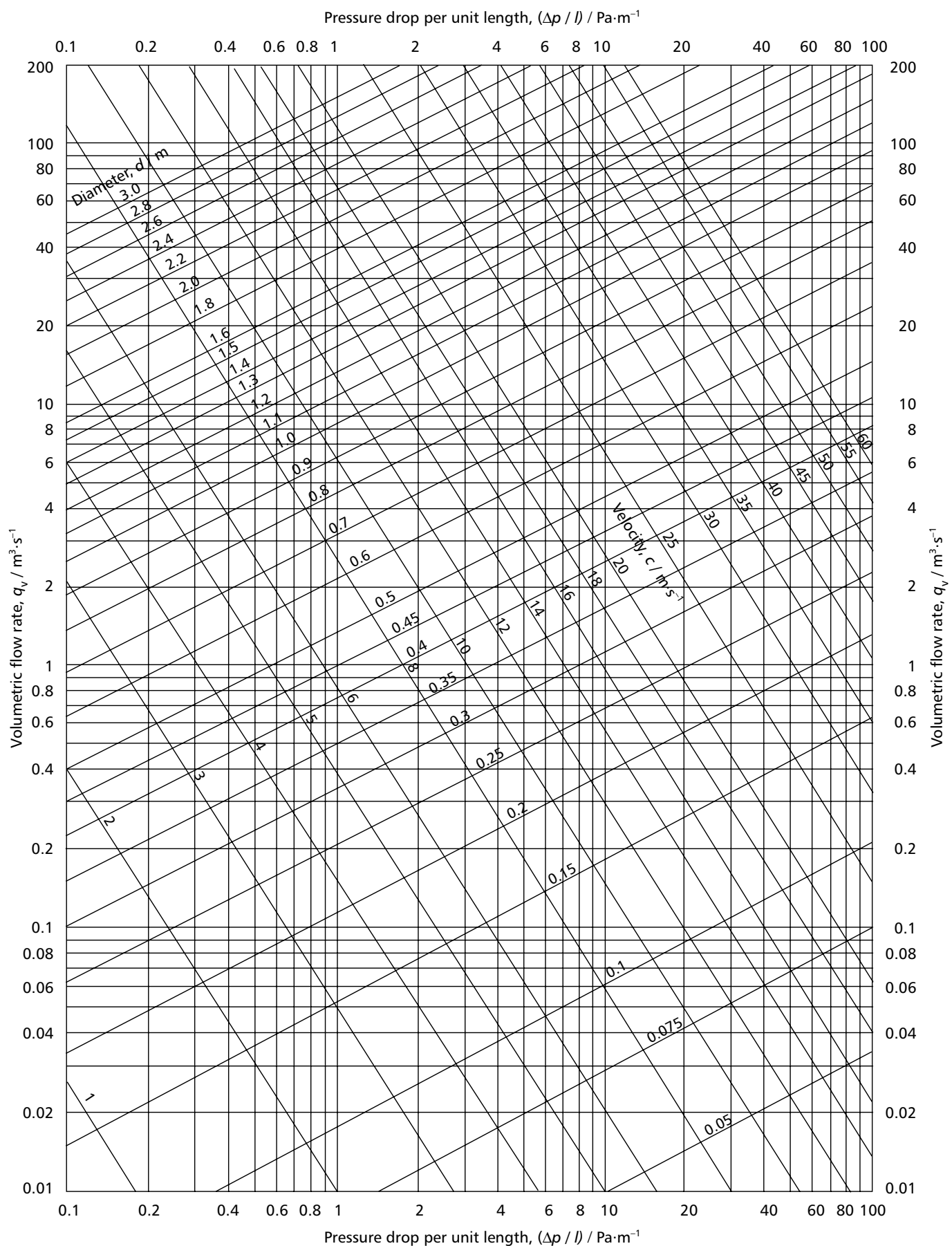

Figure 2.33 Pressure drop for air in galvanised circular ducts ( $\rho = 1.2 \text{ kg}\cdot\text{m}^{-3}$ ;  $T = 293 \text{ K}$ )

Pressure drop across the branch is given by:

$$\Delta p_t = p_{tc} - p_{ts} = \zeta_{c-s} \frac{1}{2} \rho c_c^2 \quad (2.16)$$

where  $\Delta p_t$  is the loss of total pressure across the branch (Pa),  $p_{tc}$  is the total pressure on the upstream side of the branch (Pa),  $p_{ts}$  is the total pressure on the downstream side of the branch (Pa),  $\zeta_{c-s}$  is the pressure loss factor for the branch,  $\rho$  is the density of air ( $\text{kg}\cdot\text{m}^{-3}$ ) and  $c_c$  is the air velocity on the upstream side of the branch ( $\text{m}\cdot\text{s}^{-1}$ ).

Static regain is given by:

$$p_s - p_c = \frac{1}{2} \rho (c_c^2 - c_s^2) \quad (2.17)$$

The air velocities are given by:

$$c_c = q_c / A_c \quad (2.18)$$

$$c_s = q_s / A_s \quad (2.19)$$

where  $q_c$  and  $q_s$  are the flow rates on the upstream and downstream sides of the branch respectively ( $\text{kg}\cdot\text{s}^{-1}$ ),  $A_c$  and  $A_s$  are the cross-sectional areas of the inlet to and outlet (straight flow) from the branch respectively ( $\text{m}^2$ ).

(In general,  $A_c = A_s$ , but the cross-sectional area could increase between inlet and outlet if required.)

It must be emphasised that the fan must produce a rise in *total pressure* equal to the drop in *total pressure* of the ductwork system. The deliberate use of 'static regain' does not directly influence this, except that the downstream duct sizes are larger than might otherwise have been the case.

The value of air pressure in the duct ('static pressure',  $p$ ) is only of consequence in duct air leakage calculations, and for ensuring approximately equal pressures behind any air outlets immediately on the duct itself. Sizing ductwork by the static regain method is normally carried out using a computer program.

### Choice of duct sizing method

Use of the static regain method on low- and medium-pressure systems is limited, and its worth depends on the equivalent length of the index run; the shorter the index run, the more favourable the case for the static regain method. This is because in a low-pressure system the loss of velocity pressure is small and in a large installation its recovery is not significant in comparison with the friction loss in the system.

The equal friction loss method is easier to use in design and results in smaller duct sizes. Ducts sized using this method can cost up to 8 per cent less than those sized by the static regain method. However, the savings will be at least partly offset by higher commissioning costs, especially where the index run is relatively short but with numerous branches and outlets. This reduction in duct size may not be an

option under Part L of the Building Regulations (NBS, 2010a), which limits specific fan power to  $2 \text{ W/l}\cdot\text{s}^{-1}$ .

Similar considerations apply for high-pressure systems but, because of the higher potential loss of velocity pressure and the greater need to equalise static pressures at terminals (to avoid generation of noise at terminal dampers), there will be more occasions when the static regain method is worthwhile. The additional cost of ductwork will probably be less than 1 per cent.

### Calculation of system pressure loss

The pressure loss in a ductwork system is made up of the pressure losses at plant items and terminal equipment, the friction loss in the straight ducts plus the losses due to duct fittings.

The losses due to both straight duct and fittings are directly related to the duct sizes, so that the determination of the system pressure loss follows the duct sizing process. The calculation as described, using data given in section 4.10 of CIBSE Guide C (2007), gives the 'total pressure' loss and this can be used to assess the required fan total pressure for the system. The total pressure loss of plant items and fittings is related to the static pressure loss as follows:

$$\Delta p_t = \Delta p + p_{vi} - p_{vo} \quad (2.20)$$

where  $\Delta p_t$  is the total pressure loss (Pa),  $\Delta p$  is the static pressure loss (Pa),  $p_{vi}$  is the inlet velocity pressure (Pa) and  $p_{vo}$  is the outlet velocity pressure (Pa).

In the case of plant items and fittings where the inlet and outlet connection areas and flow rates are equal, then  $p_{vi} = p_{vo}$  and the total and static pressures are identical. The advantage of using total pressure losses is that the friction and fitting losses are such that the total pressure always decreases in the direction of airflow so that the losses can simply be added. The total pressure loss of the terminals must be included in the overall total system pressure loss.

The calculation of pressure loss is essential in identifying the fan total pressure, as well as for balancing the system. It is very important to note that the total pressure loss along each duct run will always be the same. A system will always naturally balance itself so that the total losses in each run are the same. The duct sizing procedures outlined above will not normally deliver a balanced system, that is, the total pressure loss along each duct run will not normally be equal following the design process. Thus, it is crucial that the pressure loss along each run is equalised in order to deliver the design conditions, and this is normally achieved by adding dampers to balance the system.

The required fan total pressure for the system is then equal to the total pressure loss along one of the runs (which is, of course, the same as the total pressure loss along all the other runs) but it is prudent to allow a margin on the calculated total pressure loss to take account of:

- differences between the design concept and the actual installation
- the effect of system leakage on the fan duty.

Suitable air leakage margins are given in Table 2.15.

The second step is to compute the index run total pressure loss. This calculation should (for a supply system) typically include pressure losses at the following items:

- *entry*: intake opening, louvres, bird screens
- *suction duct*: straight duct sections, duct fittings, control and fire dampers, mixing chambers
- *plant*: filters (dirty condition), heaters, cooling coils, humidifiers, eliminators, attenuators
- *fan*: inlet vanes, inlet duct connection, outlet duct connection, flexible connections
- *supply duct*: straight duct sections, attenuators, duct fittings, balancing and fire dampers, zone plant items, control boxes, flexible ducting, terminals.

Extract systems will probably include many of the same items, but in a different order. Where the connections to equipment are different in size, or where multiple connections occur, the manufacturer's pressure loss data should be checked to ensure that they are the total pressure losses.

The next step in the manual calculation of the total pressure loss in a system is to identify the 'index' duct run. This is the duct run that has the greatest total pressure loss when using the duct sizing method described above: the duct sizing calculations will normally deliver a different total pressure loss for each run and the index run is the largest of these calculated pressure losses. Normally the index run will be that which links the fan and the most distant terminal. However, this is not automatically true because it is possible for shorter runs to have higher pressure losses if they contain plant items, high-pressure loss terminals or a high proportion of duct fittings.

The final step is to balance the system and here it is necessary to put in dampers to equalise the total pressure losses along each duct run, alternatively it may be necessary to consider resizing the duct to take out excess pressure. This ensures that the diameters chosen in the duct sizing process deliver the required design conditions; if dampers are not added the system will self balance and the flow rates in the ducts will depart from those originally chosen.

### *Ductwork sizing process*

Duct sizing is an iterative process following identification of the duct runs. It requires the determining of the airflow requirements in the main ducts and subsidiary branches to assess the size of each. These then need to be checked against the original design parameters. A balance needs to be obtained between the duct sizes required to achieve the design outputs and the space allocated for the ductwork system. Within an overall ductwork installation, there may be different ductwork standards, resulting in a mixture of high-, medium- and low-pressure systems. Proper sealing of ductwork will mean reduced air leakage and therefore reduced ductwork size.

Materials, equipment, fittings and construction methods need to be chosen with respect to whole-life costs, not just the initial or installation cost. It can be beneficial and cost effective to standardise the types and sizes of the ducts and fittings used in the installation.

The areas served by the risers are likely to dictate the size of the horizontal branches. The depth of horizontal ductwork will also have a significant influence on the depth of false ceilings or floors and the overall floor-to-floor height.

The depth of the horizontal element is a function of the number of the vertical risers:

- maximum number of, or space in, vertical risers equates to the minimum horizontal element depth
- minimum number of, or space in, vertical risers equates to the maximum horizontal element depth.

It is essential that ductwork is sized correctly for air velocity, particularly to avoid noise. Where noise is likely to be a problem, providing two smaller ducts in parallel (rather than a single large duct) will reduce the air velocity and hence the noise. However, energy can be wasted by reducing the duct size since this will result in increased fan power. A worked example of the duct sizing process is provided in Appendix 2.A5.

### *Computer-based sizing methods*

Computer programs have been produced that cover one or more of the following design aspects:

- duct sizing
- pressure losses in ductwork systems
- total fan pressure
- duct heat losses or gains and terminal temperatures
- acoustic analysis, with attenuation calculations from fan to terminals
- leakage analysis.

Users of computer-based sizing methods are advised to ensure that the reference data and equations used by the computer program are data provided in CIBSE Guide C (2007).

## **2.4.6 Ventilation design calculation techniques**

### **2.4.6.1 Summary and introduction**

Reliable calculations are essential for good design. Ventilation and airflow calculation methods are increasingly needed to evaluate the performance of ventilation design. To some extent they are able to replace expensive and time-consuming field tests and provide a comprehensive range of test conditions. Often, calculation methods can lead to an improved understanding of flow behaviour and provide confidence in design. They are especially important for making preliminary evaluations of complex ventilation and airflow strategies.

There are many calculation techniques available to predict ventilation and related airflow parameters in buildings. The main difficulties concern ease of use and providing suitable input data. Many advances have developed in the commercial field, especially in the areas of user-friendly access and embedded databases. As these developments continue, the ease with which calculation techniques may be applied is steadily improving.

In general, the designer is faced with a set of fixed conditions relating to the environment in which the building is located. These include climate, pollutant sources (e.g. from traffic and adjacent buildings etc.) terrain characteristics and the shielding presented by surrounding buildings.

Calculation techniques form part of the process of matching design variables (e.g. building layout, approach to ventilation etc.) with the various design constraints to achieve an optimum ventilation. Reliable results are dependent on a good working knowledge of techniques and data. More detailed calculation guidance is presented in CIBSE Guide A (2015a). CIBSE AM11: *Building performance modelling* (2015c) also provides important guidance on the integration of energy and environmental modelling for buildings.

#### 2.4.6.2 Applications

Typical applications for which numerical methods are needed include:

- estimating air change rate induced by air infiltration and ventilation
- calculating the influence of parameters such as climate and building airtightness on air change rate
- determining the rate and direction of flow through purpose-provided and air infiltration openings
- calculating the rate of airflow between rooms
- calculating the pattern of airflow within individual zones or rooms (ventilation efficiency parameters).

Subsidiary calculations, based on knowledge of airflow and ventilation prediction, include:

- determining the energy impact of ventilation
- predicting pollutant concentration (indoor air quality analysis and pollutant removal effectiveness)
- estimating the transfer of pollutants between zones or between the outside and inside of a building
- calculating room and building pressures for back-draughting or cross-contamination assessment
- the sizing of ventilation openings (to optimise ventilation performance)
- cost and energy performance analysis (e.g. to compare alternative ventilation strategies)
- thermal comfort analysis (temperature and draught risk).

Further methods are necessary to evaluate the strength of natural driving forces. These include:

- wind pressure calculation
- stack pressure calculation.

A summary of calculation methods and applications is presented in Table 2.30.

The rate and pattern of airflow throughout a building is uniquely defined by:

- the distribution and airflow characteristics of all flow paths (openings) that penetrate the building envelope and that link individual rooms; these paths include constructional cracks and gaps, intentionally provided air vents and any open windows or doors
- the pressure difference acting across each opening; this is developed by the combined effect of naturally and mechanically induced driving forces.

Additionally, the pattern of air movement within any individual space is further influenced by the:

- locations of all sources of incoming air
- temperature, velocity and turbulence of incoming air at each source
- location and flow rate of all sources of outgoing air
- distribution of flow obstructions (e.g. partitioning, furnishings and fittings)
- distribution and strength of all thermal sources and sinks
- thermal characteristics of all surfaces.

These extra needs can make the prediction of airflow patterns in enclosed spaces an extremely complex exercise.

In reality, it would be a formidable task to identify the flow characteristics, driving forces, size and location of every opening. Instead it is necessary to introduce a number of simplifying assumptions that allow the main physical concepts of airflow to be represented without compromising results. It is the degree to which the flow mechanics are simplified that identifies the type of model, the detail of data needed and the range of applicability of results. Generic forms of calculation method used for the prediction of ventilation and airflow patterns in buildings include:

- estimation from building airtightness data

**Table 2.30** Summary of calculation techniques and applications

Application	Calculation type			
	Empirical/look-up tables	Single-zone models	Multi-zone models	Computational fluid dynamics
Initial design average infiltration rate	*			
Hourly infiltration and whole-building ventilation rate and contaminant concentration		*		
Hourly room airflow rate and contaminant concentration			*	
Airflow and contaminant flow between rooms			*	
Airflow distribution within rooms				*
Room ventilation efficiency				*

- ‘simplified’ theoretical methods
- network (zonal) models
- computational fluid dynamics (CFD).

#### 2.4.6.3 Estimation from building airtightness data: estimation of average air infiltration rate for basic loading design

The simplest method for estimating air infiltration rate is by inferring it from airtightness data. For small buildings such as dwellings, the wholly empirical rule of thumb has been to divide the air change at 50 Pa (see ‘Building airtightness’ in section 2.4.7.2) by 20 to obtain the average annual infiltration rate. This however is very sensitive to building size. The method is further developed in section 4.6 of CIBSE Guide A (2015a) to take account of building size through a series of design tables and figures such as that illustrated in Figure 2.35.

##### Advantages

- It is easy to apply using both measured or design data.

##### Limitations

- It is only a very approximate solution for preliminary design purposes only. Final losses will usually need to be determined as part of a whole-building thermal analysis.
- This approach largely ignores the driving forces that vary considerably over time, so time varying changes to air change are also ignored. Therefore this is not suitable for short-term use, since the instantaneous rate of ventilation can differ considerably from the ‘average’ value.

#### 2.4.6.4 Simplified theoretical models

A much improved approach that incorporates the effects of airtightness and natural and mechanical driving forces has been developed (Sherman and Grimsrud, 1980). This adds to airtightness data by including the driving forces of ventilation (both natural and mechanical) as well as local shielding conditions that can affect wind pressure. It can thus be used for calculating hourly air change rates. The method is based on making a basic assessment of the

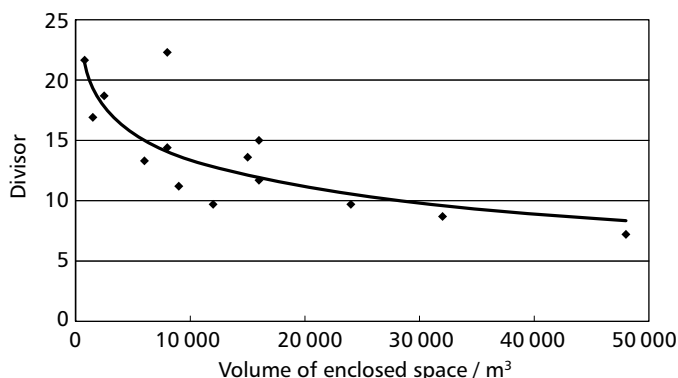

Figure 2.35 Approximate ACH at 50 Pa; divisor to obtain average annual air infiltration rate

leakage distribution and using simplified wind and stack pressure equations to determine the driving forces. The result is an estimate of total air change rate for the space.

##### Advantages

- It is a fairly simple spreadsheet calculation procedure.
- It can be used for hourly ventilation calculations taking into account airtightness, local shielding and ambient driving forces.

##### Disadvantages

- The building is treated as a single zone only.
- It calculates an air change rate only; there is no information about inflow and outflow directions through openings.

#### 2.4.6.5 Network (zonal) models

A network model is one in which a building is represented by a series of ‘zones’ or ‘cells’ interconnected by flow paths. Each ‘zone’ typically represents an individual room, while flow paths represent individual or amalgamated flow openings. These models thus provide a more rigorous incorporation of flow theory and can be used to estimate the flow rate and flow direction through defined openings in the building fabric. They can also incorporate air leakage data, specific natural ventilation openings and flow rates induced by mechanical ventilation systems. Wind and stack (buoyancy forces) are taken into account as well as wind shielding.

The pressure due to wind, stack and mechanical driving forces is calculated for each opening in the flow network. The corresponding flow rate through each opening is determined by applying a standard power law or quadratic law flow equation (see CIBSE Guide A (2015a)). The average pressure inside each zone is then iteratively adjusted until a flow balance between incoming and outgoing airflow is achieved. Zonal models can also be used to calculate steady-state contaminant concentrations within zones for given concentration sources.

There are two configurations of these models: single zone and multi zone, discussed below.

##### Single zone

This treats the building as a single open zone of uniform indoor pressure. Calculation of flow balance is relatively easy and an algorithm listing is given in Appendix 4.A3 of CIBSE Guide A (2015a).

##### Multi zone

Each room in a space is treated as a separate zone, thus the flow rate into each room can be determined. This involves a much more complex solution procedure since the flow rate into each zone as well as the whole building itself must be balanced. A popular open source algorithm is CONTAM (NIST, 2010) developed at NIST in the US. An alternative program is COMIS (AIVC, 1990).

### Advantages

- Network methods are used to calculate the rate of airflow through individual openings. Thus, this technique represents some of the closest of approximations to the true system of ventilation and infiltration airflow.
- By calculating the rate and direction of flow through each flow path, it is possible to evaluate virtually every ventilation-related parameter. Applications include the calculation of:
  - air change rate as a function of climate and building air leakage
  - ventilation and air infiltration rate (mechanical and natural)
  - the rate and direction of airflow through individual openings
  - the pattern of airflow between zones
  - internal room pressures
  - pollutant concentration
  - pollutant flow between zones and between the inside and outside of the building
  - back-draughting and cross-contamination risks.

### Limitations

- The driving forces need to be quantified and all openings in the structure of the building need to be accurately accounted for.
- It assumes that air and pollutant in each zone is uniformly mixed.
- As with the preceding methods, this approach does not provide information on pollutant distribution within the individual zones.
- It does not handle wind-driven single-sided flow.

### 2.4.6.6 Computational fluid dynamics (CFD)

Often, knowledge is needed about the pattern of airflow and the distribution of air temperature and pollutants within an enclosed space. This may be especially important to check the performance of a ventilation system, to verify comfort conditions or to predict thermal transport and smoke and fire spread prediction. In the past, design has been based on scale-model analysis and measurements of airflow patterns in full-size buildings. More recently, the application of CFD mathematical models representing the flow field has become increasingly popular. These are numerical methods that approximate the enclosure by a series of 'control' volumes or elements. Airflow in each element must follow the fundamental laws of physics covering motion, energy transport and conservation of mass.

Specific applications include the simulation and prediction of:

- room airflow
- airflow in large enclosures (atria, shopping malls, airports, exhibition centres etc.), air change efficiency

- pollutant removal effectiveness
- temperature distribution
- air-velocity distribution (for comfort, draughts etc.)
- turbulence distribution
- pressure distribution
- fire and smoke movement
- airflow around buildings (for wind-pressure distribution).

### Simulation approach

The space to be simulated is 'discretised' into a set of control volumes or elements. Typically, the enclosure may be divided into 500 000–2 000 000 control volumes or more; therefore each element represents only a fraction of the total enclosure volume. The system of discretisation can be non-uniform so that clusters of elements can be located at areas of greatest interest. Flow, energy propagation and contaminant spread are represented in each of the control volumes by a series of discretised transport equations. In structure, these equations are fundamentally identical but each one represents a different physical parameter. Direct solution techniques are not available, so iteration is applied. Parameters are initially given arbitrary values from which the iteration can commence. These values are then adjusted until each of the transport equations balances. The process of reaching a balance is referred to as 'convergence'. Considerable computational effort is normally necessary, with the result that processing times can be lengthy, sometimes taking many hours.

### Key parameters

Key parameters calculated as part of a CFD analysis include:

- *Pressure distribution*: airflow is driven by the pressure distribution, therefore the pressure field is fundamental to the whole flow process. Pressure is maintained by a combination of driven air or forced convection and by buoyancy forces or natural convection. Forced convection is driven by mechanical ventilation or the natural flow of air through openings. Free convection is driven by buoyancy forces created by imbalance in temperature difference.
- *Velocity field*: air movement is a vector having components in both speed and direction. To determine the air velocity distribution, airflow must usually be represented by three transport equations.
- *Temperature field*: the temperature field is sustained by thermal sources and sinks distributed about the enclosure. Sources can include heat emitters, solar gain and surfaces warmed by radiation. Sinks can include chilled ceilings and cold surfaces such as windows or uninsulated walls. Buoyancy forces and free convection currents are generated by the temperature field. Temperature is a scalar quantity acting only on the vertical component of velocity field through a gravitational term.
- *Turbulence*: turbulence is the random fluctuation of the airstream from its mean flow direction. It contributes to the rapid mixing of air and pollutants

in the space and thus has a major impact on the flow field and pollutant distribution. The representation of the turbulence of room air currently presents a challenge to the credibility of CFD techniques. Turbulence must be accurately represented but the representation of turbulence is usually highly empirical. This is because the scale length of turbulence is usually much smaller than the grid size that can practicably be used in a CFD simulation. Modelling turbulence has, therefore, become an important area of research and is an area that is most likely to lead to erroneous results. Modern techniques are increasingly adopting a large eddy simulation (LES). In this method the most significant scale of turbulence is represented by grid size. However considerable computing capacity is needed.

- *Boundary layer flow:* airflow close to surfaces is subjected to boundary layer effects in which the rate of flow is influenced by surface friction. This further adds to the complexity of flow modelling.

**Advantages**

- It can be used to calculate steady-state and transient airflow patterns within a space.
- It can also be used to calculate associated pollution distribution and ventilation effectiveness parameters.

**Disadvantages**

- It is often difficult to validate results.
- Complex calculation techniques require meticulous setting up.

- Turbulence can be difficult to represent, thus risking erroneous results.

**2.4.7 Ventilation design measurement techniques**

**2.4.7.1 Introduction**

Measurement methods for airflow and related parameters are essential for commissioning, diagnostic analysis, design and research. Many techniques have been developed with each having a specific purpose. The intention of this section is to present a summary of measurement methods, principally for design, and to provide guidance on the selection of techniques according to application. Comprehensive information on measurement techniques is published by Charlesworth (1988) and Roulet (1991). In addition, a simplified discussion is presented in *AIVC Guide to Energy Efficient Ventilation* (Liddament, 1996) on which the following discussion is based. Typical measurement requirements cover:

- building airtightness
- duct airtightness
- ventilation rate
- ventilation effectiveness
- airflow characteristics and air movement
- airflow through terminal units and ducts
- pressure distribution and airflow around buildings.



Figure 2.36 Airtightness testing: (a) blower door and (b) trailer fan (reproduced courtesy of BSRIA Compliance)

### 2.4.7.2 Measuring airtightness

The main objectives of an airtightness test are to:

- determine the leakage rate of air through a building component or duct at a specified test pressure
- determine the relationship between air leakage and pressure over a typical operating pressure range.

#### *Building airtightness*

In the UK airtightness requirements for building are covered by Part L of the Building Regulations (NBS, 2013a). Testing usually requires a whole-building pressurisation test to determine the air leakage at a reference pressure of 50 Pa. This is the average pressure between the inside and outside of the building. The conduction of the test is covered by a protocol as described in CIBSE TM23: *Testing buildings for air leakage* (2000c). The 50 Pa reference pressure is selected on the basis that results will not be adversely affected by wind and stack pressures under calm conditions but is not sufficiently high for the generated pressure itself to distort leakage openings physically (either by opening or closing them). Despite this there is invariably a difference in results between pressurising and depressurising a building as a consequence of the behaviour of leaks.

Measurements are made using a ‘blower door’ (Figure 2.36(a)) or, in the case of very large buildings, a ‘trailer fan’ (Figure 2.36(b)) to create incremental pressure differences between the inside and outside of a building in the  $\pm 100$  Pa pressure range. For each pressure increment, the corresponding airflow rate through the fan is measured. The relationship between induced pressure and flow rate is then plotted. From this, the air leakage rate at 50 Pa is determined by interpolation as well as the pressure flow characteristics. The flow characteristics are commonly described by the power law equation as described in CIBSE Guide A (2015a).

By carrying out multiple pressure tests between zones, the airtightness of individual rooms and leakage across party walls can be determined.

#### *Duct airtightness*

In the UK it is recommended as good practice that all significant installations (e.g. those with a fan capacity greater than  $1 \text{ m}^3\text{-s}^{-1}$ ) should be tested in accordance with DW/143: *Guide to Good Practice: Ductwork Air Leakage Testing* (BESA, 2013b). Duct testing is also a requirement of Part L of the Building Regulations (NBS, 2013a) in England (and related requirements for Scotland, Wales and Northern Ireland).

### 2.4.7.3 Leak detection

Simple leak detection methods are necessary to track design faults and poor workmanship. Suitable methods are outlined below.

#### *Smoke methods*

Leaks may be detected by fan pressurising a building or an individual room within a building and observing the

movement of smoke emitted from a smoke stick or puffer. This approach is very effective and easy to undertake. The smoke source is gently moved in the vicinity of potential sources of leaks during the course of the test. Sometimes leak locating and sealing may be undertaken while conducting a routine pressurisation test. Ideally, the building or room should be pressurised at positive pressure so that the flow of smoke, from inside to outside, can be clearly identified.

#### *Thermography*

Leaks may also be located by thermography. Testing may be undertaken from either the inside or outside of the building. For indoor testing, the building or room is depressurised to permit the ingress of cold outdoor air. An interior thermographic scan will indicate the location of fabric leaks.

Alternatively, scanning can be undertaken externally, in which case the building is pressurised and the sources of exfiltrating hot air are located. This may be undertaken on a cold night when it is possible to locate air leaks and location of excessive fabric heat loss arising from inadequate or poorly installed insulation.

#### *Limitations*

- Leak detection does not quantify the infiltration loss but only identifies the source of leaks.
- Infrared thermography is costly and experience is needed to interpret results.

### 2.4.7.4 Measuring ventilation rate

#### *The tracer gas technique*

Fresh air ventilation rate is commonly determined using the ‘tracer gas’ technique. This tends to be a specialist task rather than routine and therefore requires specialist contractors. A tracer gas is ideally an inert gas that is non-toxic, measurable at low concentrations and not normally present in the atmosphere. In the past, nitrous oxide and sulphur hexafluoride were commonly used. However, neither of these would probably now be acceptable where occupants are present. Also  $\text{SF}_6$  is a substantial greenhouse gas and its general use has largely been banned. The remaining choice is carbon dioxide, which is generated by people (metabolic  $\text{CO}_2$ —see section 2.2.2.4) or is otherwise readily available and is perfectly safe at transient concentrations up to 5000 ppm.

To make a measurement, tracer gas is emitted into the space to be tested and is well mixed using mixing fans. These fans are then switched off and concentration behaviour under normal room conditions is observed. Various emission configurations are possible including:

- Concentration decay: the tracer gas injection is switched off and the decay in concentration over time is monitored. For a uniform ventilation rate, the decay is logarithmic with respect to time and the air change rate is proportional to the log gradient.
- Constant concentration: gas is injected at a sufficient rate to maintain a constant concentration.

The ventilation rate is proportional to the gas injection rate. This test requires sensitive feedback controls and actuators, thus adding to complexity.

- Constant emission: the tracer gas is discharged at a constant rate. Air change rate can be determined from the corresponding time varying room concentration. Eventually a steady state may be reached, at which point this test corresponds to a constant concentration test. At all times the concentration of tracer gas must be carefully monitored to ensure that the safe concentration of tracer gas is not exceeded.

In all cases, tracer gas blends with incoming air that is not treated with tracer gas. This could be fresh outdoor air or it could be infiltrating air from adjacent rooms. To determine the fresh air ventilation rate into a space the following options must be considered.

- The entire enclosure must be tested as a single entity.
- The constant concentration method is used in which all adjacent rooms are held at the same concentration as the test room. The injection rate in the test room will therefore be proportional to the unseeded outdoor air.

Airflow between rooms can be determined by using multiple tracers.

#### *'Passive' tracer gas techniques*

A variation on the tracer gas technique is the 'passive' tracer gas method. This technique is used to estimate the average air change rate into a building over an extended period of time. It is a method that was pioneered by Dietz and Cote (1982). It is based on the use of volatile perfluorocarbon tracers (PFTs), which may be detected in the air in minute concentrations within the parts per trillion range. The tracer gas is gradually emitted over a period of time within the test space. An exposed sample tube is used to adsorb the gas over the same time period. Air change rate is calculated from the amount of gas emitted and collected by the emission and sample tubes respectively. Analysis of the sample tubes is undertaken in a laboratory using gas chromatograph and electron capture detection. Recent developments are described by Upton and Kukadia (2011).

The concentration of tracer is so small that it is regarded as having no toxic impact. It may therefore be used in occupied dwellings, offices or other buildings. Test periods can vary from a few hours to several months. By using more than one test gas, it is also possible to use this method to analyse airflow between zones. This method is inexpensive and unobtrusive. It may easily be applied to occupied spaces and may be conducted by relatively unskilled operators.

There are various limitations to this approach, including the following.

- This method is only accurate if air change remains reasonably constant over the measurement time.
- This approach provides insufficient weighting to peaks in air change, such as those associated with airing, door opening or transient high infiltration driving forces, i.e. transient changes in conditions are not 'seen'.

Arguably, if the objective of the measurement is to estimate the average pollutant dose received by occupants in a space resulting from a constant emitting pollutant source (e.g. furnishings and fittings), this method provides a reliable result. However, it can ignore the benefit of ventilation for transient pollutant emissions (e.g. airing for washing and cooking) and underestimate ventilation-related thermal losses (especially through open windows).

#### **2.4.7.5 Measuring ventilation effectiveness**

Ventilation effectiveness is a measure of how well air is mixed in a space (see section 2.2.8). This can be measured using the tracer gas technique. Gas is discharged in the occupied zone and the concentration is measured at key points including the extract grille and occupant workstations. Key characteristics are as follows.

- A similar concentration in the occupied zone and extract grille indicates perfect mixing.
- A lower concentration in the extract grille than the occupied space indicates short circuiting, i.e. the supply air reaches the extract grille before mixing in the space.
- A higher concentration in the extract grille than at individual occupant workstations indicates successful displacement ventilation. The lower the workstation concentration, relative to the extract grille concentration, the better the displacement flow.

#### **2.4.7.6 Airflow distribution in a space**

Monitoring of airflow in a space may be necessary to evaluate a system of identify faults. Primarily this is a research and development tool. It may also be used in conjunction with CFD analysis (see section 2.4.6.6).

Applications include the:

- measurement of flow velocity and air turbulence throughout a space
- evaluation of diffuser performance
- response to thermal parameters and flow obstruction to airflow patterns.

Methods are based on qualitative visualisation approaches and quantitative anemometric techniques as outlined below.

#### *Visualisation techniques*

A qualitative assessment of airflow pattern and turbulence can be made by applying a number of visualisation techniques. These are based on developing a two-dimensional sheet of bright light, which is directed across a section of room. Smoke or small bubbles are used to highlight the flow pattern. These may be photographed or recorded using a video camera.

#### *Limitations*

- Qualitative methods are fairly easy to perform but provide only visual information.

### *Anemometry (hot wire)*

Anemometry is used to give quantitative evaluation of spatial air velocity and turbulence distribution. Anemometers must be very sensitive and are usually based on 'hot wire' techniques. A resistance wire (the anemometer element) is heated while the current through the wire is monitored. Air speed fluctuations rapidly change the temperature and, therefore, the resistance of the wire. The resultant current change provides a measure of instantaneous air speed (turbulence). Hot wire anemometers are used in 'test' chamber studies where 'traverses' are made across sections of the chamber to build up a complete pattern of airflow information.

#### *Limitations*

- Quantitative (anemometric) techniques are complex and time consuming and therefore tend to be restricted to research or product (diffuser) development applications.
- Measurements give snapshot results only. In reality, the pattern of airflow will vary depending on the location of obstructions and the balance between forced and free convection forces.
- Small changes to conditions can vastly influence airflow pattern.

#### *Flow distribution: flume models*

Flume models provide a method by which air movement, pollutant transport and temperature distribution can be predicted using scale models inserted in a water flume. They have been used to assist in the design of a variety of buildings and to predict the transient pattern of airflow. Specific applications include:

- predicting the role and pattern of airflow and pollutant transport through defined openings
- predicting flow patterns through a building
- predicting flow and pollutant distribution in individual rooms.

A 1:20 to 1:100 scale model of the building is constructed using transparent Perspex. This model is necessarily simplified but the essential features controlling the ventilation process, including envelope openings and openings between individual rooms, are retained. This model is completely immersed in a glass-sided water channel such that the pattern of flow can be observed using a video camera. Buoyancy-induced flow (density stratification) is represented by sources of dense salt solution to which a tracer dye is added. The model and video camera are inverted so that the salt solution appears to rise. Cooling is similarly simulated using a less dense alcohol water mixture. Quantitative measurements of flow velocities are made by measuring samples of salt solution taken from within the model. Automated image processing of the video film allows the measurement of dye intensities to give the instantaneous temperature distribution throughout the building, while flow velocities can be measured by particle tracking. Mixing and diffusion processes may also be quantified.

#### *Limitations*

- Flume models require considerable laboratory space, thus restricting this approach to the laboratory.
- Primarily this method provides an aid to assessing the impact of stack-induced airflow. The wind regime is more difficult to predict, since it is not usually possible to incorporate surrounding obstructions.
- It is not really practicable to represent infiltration or other openings resulting from construction technique or poor site practice.

#### **2.4.7.7 Airflow through terminal units and ducts**

Flow measurements through individual ventilation openings are needed to ensure that the airflow rate and flow direction conform to design requirements. They are also needed to balance ventilation systems as part of servicing or commissioning. Examples include:

- monitoring the flow through passive ventilation stacks
- monitoring the performance of mechanical ventilation systems
- measuring naturally or mechanically driven airflow through air inlets and outlets.

Basic anemometry systems are straightforward to use but might not be as accurate as more complex methods.

Techniques are based on standard airflow measuring instrumentation and include those listed below.

#### *Orifice plates and nozzles*

These are calibrated devices that are fitted in series with ductwork and have a known relationship between airflow rate and pressure drop relationship. The flow rate is determined by measuring the pressure drop across the device. Long, straight lengths of duct are needed both upstream and downstream of the system while the constriction imposed by the orifice or nozzle can impede flow.

#### *Pitot-static traverses*

Air velocity at a specific location is commonly measured using a pitot-static tube. Duct airflow can be measured by inserting the tube into a prepared opening and measuring the air speed at several depths across the cross-section of the tube. The total flow rate is determined by integrating the results.

Several types of anemometer are used to measure the flow rate through ducts and openings; these include vane anemometers and hot wire anemometers. The vane anemometer is the most likely device for use in servicing and commissioning since it is robust and is satisfactory for measuring relatively high airflow velocities. Hot wire anemometers are delicate, precision devices for measuring very low flow rates and turbulent fluctuations (see 'Anemometry (hot wire)' in section 2.4.7.6).



Figure 2.37 Flow hood (reproduced courtesy of BSRIA Compliance)

### Flow hoods

Anemometers can disrupt or impede the flow of air through an opening, thus introducing error, especially if the flow rate is low. One device specifically designed to overcome this problem and to monitor the direction and rate of airflow through an opening is the flow hood. Developed in conjunction with the Netherlands Organisation for Applied Scientific Research (TNO) (Phaff, 1988), it is an active device containing its own calibrated fan, which is operable over a flow range of between 0 and 225 m<sup>3</sup>·h<sup>-1</sup>. The funnel opening of the flow hood is placed over the opening through which the flow rate is to be measured, forming an airtight seal. The internal fan speed is adjusted until there is zero pressure difference across the opening. The resultant flow rate through the device is equivalent to the undisturbed flow rate through the opening. The impact of the measurement system on the rate of flow is therefore substantially minimised. An example of a flow hood is shown in Figure 2.37.

### Tracer gas injection

Sometimes, tracer gas injection is used to measure airflow rate. Tracer gas is injected into the duct at a constant known rate. The flow rate of air through the duct is proportional to the tracer concentration measured in the duct.

#### 2.4.7.8 Pressure distribution and airflow around buildings

The wind pressure distribution is needed to calculate the flow rate through building envelope openings. Accurate design requires knowledge relating to a particular building shape and location. The following method may be used.

Wind tunnel testing provides detailed information on spatial pressure distribution. It can also be used to assess airflow patterns around buildings and air intake contaminant ingress risks.

A scale model of the building and immediate surroundings is produced that can fit within the working section of a boundary layer wind tunnel. Pressure taps connected via plastic tubing are placed on each face of the model so that the pressure distribution can be determined. The model needs to be placed on a turntable so that pressure can be analysed for the complete spectrum of wind direction. Wind speed is determined with respect to a specific datum height, normally corresponding to the height of the building. Upwind roughness is normally developed using an array of cubic blocks. Smoke combined with photography is often used to provide visualisation of the flow regime.

An ‘environmental or boundary layer’ wind tunnel that can accurately represent the lower levels of the Earth’s turbulent boundary layer and accommodate reasonably sized scale models of the building and surrounding environs is necessary. These are restricted to laboratory applications on scale models. A typical minimum scale for analysis of wind pressure distribution is 1:50. Models must also incorporate an accurate representation of the surrounding environment.

CFD is also used to assess wind pressures on buildings with several commercial models being available. In all instances care needs to be taken to ensure proper validation in order to obtain accurate results. Typical problems relate to the choice of turbulence model and selection of the correct grid size and layout.

## 2.5 Other design considerations

### 2.5.1 Introduction

In developing ventilation strategies there are other important design considerations that need to be addressed. These are covered in this section and include:

- noise
- fire and smoke protection
- air leakage.

Energy and carbon performance considerations are discussed in 2.1.4.

### 2.5.2 Noise

Both natural and mechanical systems can present noise problems. General guidance on acceptable noise levels can be found in CIBSE Guide A (2015a). The following provides information on noise sources and abatement. More detailed information is covered in CIBSE Guide B4 (2016c).

#### 2.5.2.1 Outdoor noise

Local noise sources can be continuous, such as traffic, industrial processing and low-flying aircraft; other sources might be regular, such as playgrounds or entertainment

and sports venues; while other sources might be random, such as construction sites and road maintenance or noise from adjacent buildings. In each case, noise levels should be assessed and incorporated in the ventilation design. External noise can be a particular problem in the case of natural ventilation when windows face busy main roads or are within 100 m of a railway line. A partially open window typically has a weighted sound reduction index of 10–15 dB compared with 35–40 dB for thermally insulating double glazing (BSI, 2014b). Measures to improve acoustic performance include:

- the use of acoustic baffles
- siting the opening windows on a quiet side of a building
- the use of acoustic ventilators (as opposed to windows)
- placing buffer zones (e.g. a circulation space) adjacent to the noise source.

Outside noise is of particular concern in schools. *Acoustic Design of Schools* (EFA, 2004) contains detailed design guidance on minimising noise impact).

### 2.5.2.2 Indoor noise sources

As well as the ingress of external noise, and noise generated from mechanical systems, consideration also needs to be given to internal acoustic design issues including:

- conflict between partitioning for acoustic privacy and provision of air paths
- that exposed thermal mass increases the number of hard surfaces (see section 2.4.2.4).

Indoor noise can be generated by:

- occupants
- equipment
- mechanical ventilation systems.

### 2.5.2.3 Noise from ductwork and HVAC plant

Noise generation increases rapidly with increases in velocity at grilles, bends and other fittings where the flow separates from the walls, leaving turbulent eddies in its wake. The noise generated at grilles and terminals is of particular importance. High-velocity systems require noise

**Table 2.31** Noise-reduction methods for various noise sources and transmission paths

Path	Description	Noise-reduction measures
(a)	Direct sound radiated from sound source to ear Reflected sound from walls, ceiling, and walls	Direct sound can be controlled only by selecting quiet equipment. Reflected sound is controlled by adding sound absorption to room and to location of equipment.
(b)	Air- and structure-borne sound radiated from casings and through walls of ducts and plenums is transmitted through walls and ceiling into room	Design ducts and fittings for low turbulence; locate high velocity ducts in non-critical areas; isolate ducts and sound plenums from structure with neoprene or spring hangers.
(c)	Airborne sound radiated through supply and return air ducts to diffusers in room and then to listener by path (a)	Select fans for minimum sound power; use ducts lined with sound absorbing material; use duct silencers or sound plenums in supply and return air ducts.
(d)	Noise is transmitted through plant/equipment room walls and floors to adjacent rooms	Locate equipment rooms away from critical areas; use masonry blocks or concrete for equipment room walls and floor.
(e)	Building structure transmits vibration to adjacent walls and ceilings from which it is radiated as noise into room by path (a)	Mount all machines on properly designed vibration isolators; design equipment room for mechanical dynamic loads; balance rotating and reciprocating equipment.
(f)	Vibration transmission along pipe and duct walls	Isolate pipe and ducts from structure with neoprene or spring hangers; install flexible connectors between pipes, ducts, and vibrating machines.
(g)	Noise radiated to outside enters room windows	Locate equipment away from critical areas; use barriers and covers to interrupt noise paths; select quiet equipment.
(h)	Inside noise follows path (a)	Select quiet equipment.
(i)	Noise transmitted to diffuser in a room into ducts and out through an air diffuser in another room	Design and install duct attenuation to match transmission loss of wall between rooms.
(j)	Sound transmission through, over and around room partitions	Extend partition to ceiling slab and tightly seal all around; seal all pipe, conduit, and duct penetrations.
Noise source	Transmission paths	
Circulating fans; grilles; diffusers; registers; unitary equipment in room	(a)	
Induction coil and fan-powered mixing units	(a), (b)	
Unitary equipment located outside of room served; remotely located air handling equipment, such as fans and blowers, dampers, duct fittings and air washers	(b), (c)	
Compressors and pumps	(d), (e), (f)	
Cooling towers; air-cooled condensers	(d), (e), (f), (g)	
Exhaust fans; window air conditioners	(g), (h)	
Sound transmission between rooms	(i), (j)	

control by using sound-absorbent units between the duct system and the room outlets and inlets.

Noise in ductwork can be contentious, particularly where the system or components (e.g. intake, exhaust, AHU etc.) produce a noise nuisance to the building occupants, neighbours or passers-by. Noise is generated where eddies are formed as flow separates from a surface.

The generated noise level is particularly sensitive to the velocity (see CIBSE Guide B4 (2016c)).

The velocity of air flowing through a duct can be critical, particularly where it is necessary to limit noise levels. Recommended velocities for particular applications, using the BESA system classifications to control noise, are given in Table 2.16.

Table 2.31 lists noise-transmission paths for a variety of sound sources and suggests appropriate methods of noise reduction (SMACNA, 2006).

## 2.5.3 Fire and smoke protection

### 2.5.3.1 General

Building Regulations in the UK require that buildings be subdivided, with fire-resisting construction depending on size and use, to inhibit the spread of fire within the building. Advice on the degree of compartmentation and fire-resisting periods are given in Part B of the Building Regulations (NBS, 2013g).

In addition, Part J of the Building Regulations (NBS, 2013f) has specific legal requirements:

- 38.—(1) This regulation applies where building work—
- (a) consists of or includes the erection or extension of a relevant building; or
  - (b) is carried out in connection with a relevant change of use of a building,
- and Part B of Schedule 1 imposes a requirement in relation to the work.
- (2) The person carrying out the work shall give fire safety information to the responsible person not later than the date of completion of the work, or the date of occupation of the building or extension, whichever is the earlier.
- (3) In this regulation—
- (a) “fire safety information” means information relating to the design and construction of the building or extension, and the services, fittings and equipment provided in or in connection with the building or extension which will assist the responsible person to operate and maintain the building or extension with reasonable safety;
  - (b) “relevant building” is a building to which the Regulatory Reform (Fire Safety) Order 2005 [RRFSO, 2005] applies, or will apply after the completion of building work;
  - (c) “relevant change of use” is a material change of use where, after the change of use takes place, the Regulatory Reform (Fire Safety) Order 2005 will apply, or continue to apply, to the building; and
  - (d) “responsible person” has the meaning given by article 3 of the Regulatory Reform (Fire Safety) Order 2005.

The RRFSO (TSO, 2005) makes each building user, via a responsible person, liable for all fire safety within a building. However, in passing over the information, liability is not devolved from a designer, installer or manufacturer and remains in place.

See also CIBSE Guide E: *Fire engineering* (2010) for general guidance on fire protection.

Information on fire-resisting and smoke-control ductwork is given in the *Fire Rated and Smoke Outlet Ductwork* (‘the ASFP Blue Book’) (ASFP, 2000). Fire-resisting ductwork is tested to BS EN 1363-1: 2012: *Fire resistance tests. General requirements* (BSI, 2012c) and classified to BS EN 13501-3: 2005 + A1: 2009: *Fire classification of construction products and building elements. Classification using data from fire resistance tests on products and elements used in building service installations: fire resisting ducts and fire dampers* (BSI, 2005b). Fire-resisting ductwork may also be tested under BS 476-24: 1987: *Fire tests on building materials and structures. Method for determination of the fire resistance of ventilation ducts* (BSI, 1987c) but this does not allow classification to BS EN 13501-3 (BSI, 2005b). Smoke control ductwork may be tested under BS EN 1366-8: 2004: *Fire resistance tests for service installations. Smoke extract ducts* (BSI, 2004) and BS EN 1366-9: 2008: *Fire resistance tests for service installations. Single compartment smoke extraction ducts* (BSI, 2008b) for single and multiple compartment applications respectively, for classification to BS EN 13501-4: 2007 + A1: 2009 (BSI, 2007c). CE marking is now mandatory.

Information on fire dampers is given in *Fire Dampers (European Standards)* (‘the ASFP Grey Book’) (ASFP, 2010) and DW/145: *Guide to Good Practice for the Installation of Fire and Smoke Dampers* (BESA, 2010). Fire dampers are tested to BS EN 1366-2: 2015: *Fire resistance tests for service installations. Fire dampers* (BSI, 2015a) and classified to BS EN 13501-3 + A1: 2009: (BSI, 2005b). There is a product standard and this is BS EN 15650: 2010: *Ventilation for buildings. Fire dampers* (BSI, 2010b). CE marking is now mandatory.

In some cases fire dampers may be tested to BS 476-20: 1987/BS 476-22: 1987 (BSI, 1987a/b) should all the fans be turned off in the event of a fire alarm. This does not allow classification to BS EN 13501-3: 2005 + A1: 2009 (BSI, 2005b).

Fire dampers protecting escape routes and in most cases areas with sleeping risk must have an ES classification to BS EN 13501-3 + A1: 2009 (BSI, 2005b) and this is not possible for a fire damper tested to BS 476-20: 1987/BS 476-22: 1987 (BSI, 1987a/b) alone.

In all cases fire-resisting products should be installed as tested, otherwise fire-resistance performance is not guaranteed. This does mean separate fire test reports for different wall and floor constructions. Some assessment may be available, but this is rare for dampers tested to BS EN 1366-2: 2015: *Fire resistance tests for service installations* (BSI, 2015a).

The following notes summarise the main fire precautions issues relating to the design and installation of ductwork systems. Advice on fire-protection systems is laid down in Approved Document B and supplemented in BS 9999: 2008: *Code of practice for fire safety in the design, management and use of buildings* (BSI, 2008a).

Fire and smoke containment and hazards are factors that influence the design and installation of ductwork systems.

A design that is required to perform a particular action as part of a fire strategy is likely to combine electrical,

mechanical and builders' work components, which would be influenced by the normal day-to-day operation requirements. Some of the more common components are:

- ductwork
- fire dampers
- smoke extract fans.

Ductwork is often required to transmit heat and smoke from the fire zone to the outside. The layout, jointing and potential expansion in the ductwork must be designed to withstand the calculated temperatures while maintaining integrity (to ensure containment of smoke and possibly heat) and insulation (to prevent spread of fire by radiation at high temperatures). The need for fire protection should be based on compartmentation requirements and calculated smoke temperatures. Where the fire-resistant ductwork passes through a wall or floor, a penetration seal must be provided that has been tested and/or assessed with the fire-resisting ductwork to the same fire rating as the compartment wall through which the fire-resisting ductwork passes. Where the fire-resisting ductwork passes through the fire compartment wall or floor, the ductwork itself must be stiffened to prevent deformation of the duct in a fire to:

- maintain the cross-sectional area of the duct
- ensure that the fire-rated penetration seal around the duct is not compromised.

Fire dampers are provided in ductwork for fire containment by preventing flow when a predetermined temperature is reached. The operation is usually activated by a fusible link that releases the damper at 72 °C. Generally they are required where ducts penetrate walls or floors that form fire compartments. The damper assembly should have a fire-resistance rating equal to that of the fire barrier it penetrates. It should be fire tested as detailed above.

Fire dampers would not normally be specified in ductwork used for smoke transport, although they may be required as part of the overall fire strategy in other ductwork. These would become smoke control dampers. Various types of fire damper are available: simple E classified integrity only units and ES classified fire dampers with reduced leakage for fire and smoke control. Details are given in DW/144: *Specification for Sheet Metal Ductwork* (BESA, 2013a) and DW/145: *Guide to Good Practice for the Installation of Fire and Smoke Dampers* (BESA, 2010).

Electrically controlled dampers are required in some circumstances to control the flows, depending on the location of the fire and the control system logic as determined by the requirements of the fire strategy. Fire dampers responding to smoke alarms are required to protect escape routes and areas with sleeping risk (BSI, 2008a).

Smoke extract fans must be selected to ensure reliability at the design temperature and length of exposure as predicted by the fire engineering calculations. These should reflect performances as detailed in BS EN 12101-3: 2015: *Smoke and heat control systems. Specification for powered smoke and heat control ventilators (Fans)* (BSI, 2015b).

Natural smoke ventilators should reflect the requirements of BS EN 12101-2: 2003: *Smoke and heat control systems. Specification for natural smoke and heat exhaust ventilators* (BSI, 2003b).

### 2.5.3.2 Main areas within a building where ductwork should be fire protected

Agreement for these areas should be sought from the building control officer responsible for the building. Reference should also be made to the current Building Regulations.

#### *Smoke extract systems*

If the ductwork incorporated in a smoke extract system is wholly contained within the fire compartment, it must be capable of resisting the anticipated temperatures generated through the development of a fire. This may be demonstrated by testing to BS EN 1366-8: 2004 (BSI, 2004) and BS EN 1366-9: 2008 (BSI, 2008b) or BS 476-20: 1987 (BSI, 1987a). BS 476-24: 1987 (BSI, 1987c) also requires that ductwork that is intended as a smoke extract must retain at least 75 per cent of its cross-sectional area within the fire compartment. If the ductwork penetrates a fire-resisting barrier, it must also be capable of providing the same period of fire resistance as the barrier.

#### *Escape routes covering stairways, lobbies and corridors*

All escape routes must be designed so that the building occupants can evacuate the building safely in the case of fire. Ductwork that passes through a protected escape route must have a minimum of 30 minutes' fire resistance and be at least equal to the fire compartment through which the ductwork passes, either by the use of fire dampers or fire-resisting ductwork. Any fire dampers used should have an ES classification to BS EN 13501-3: 2005 + A1: 2009 (BSI, 2005b). The performance of the penetrated partition must also be maintained.

#### *Non-domestic kitchen extract systems*

Where there is no immediate discharge to atmosphere, i.e. the ductwork passes to atmosphere via another compartment, fire-resistant ductwork must be used. Kitchen extract ductwork presents a particular hazard, as combustible deposits such as grease are likely to accumulate on internal surfaces; therefore, all internal surfaces of the ductwork must be smooth. A fire in an adjacent compartment through which the ductwork passes could lead to ignition of the grease deposits, which may continue through the ductwork system possibly prejudicing the safety of the kitchen occupants. For this reason consideration must be given to the stability, integrity and insulation performance of the kitchen extract duct which should be specially tested to BS EN 1366-9 (BSI, 2008b) or BS 476-24: 1987 (BSI, 1987c) for a kitchen rating.

Particular points to note are as follows:

- Access doors for cleaning must be provided at distances not exceeding 3 m.
- Fire dampers must not be used.
- Use of volume control dampers and turning vanes are not recommended.

Further information on kitchen extract systems is contained in DW/172: *Specification for Kitchen Ventilation Systems* (BESA, 2005).

### *Enclosed car parks that are mechanically ventilated*

Car parks must have separate and independent extract systems, designed to run in two parts, each extracting 50 per cent of the design load. Fans are required to be rated at 300 °C for a typical period of two hours and the ductwork and fixings constructed from materials with a melting point not less than 800 °C. Full details of the requirements are given in Part B of the Building Regulations (NBS, 2013g).

Due to the fire risks associated with car parks, these systems should be treated as smoke extract systems and therefore maintain a minimum of 75 per cent cross-sectional area under fire conditions in accordance with BS EN 1366-8: 2004: *Fire resistance tests for service installations* (BSI, 2004) or BS 476-24: 1987: *Fire tests on building materials and structures* (BSI, 1987c). Fire dampers must not be installed in extract ductwork serving car parks.

### *Basements*

Ductwork from basements must be fire rated except for car parks as above. If basements are compartmented, each separate compartment must have a separate outlet and have access to ventilation without having to gain access (i.e. open a door to another compartment). Basements with natural ventilation should have permanent openings, not less than 2.5 per cent of the floor area and be arranged to provide a through draft with separate fire ducts for each compartment. See Part B of the Building Regulations (NBS, 2013g) for full details.

### *Pressurisation systems*

Pressurisation is a method of restricting the penetration of smoke into certain critical areas of a building by maintaining the air at higher pressures than those in adjacent areas. It applies particularly to protected stairways, lobbies, corridors and fire-fighting shafts serving deep basements, as smoke penetration to these would inhibit escape. As the air supply providing pressurisation must be maintained for the duration of a fire, fire dampers cannot be used in the ductwork to prevent spread of fire. Any ductwork penetrating fire-resisting barriers must be capable of providing the same period of fire resistance.

Good practice in such systems requires the following.

- *Holes in compartment walls and floors:* all builders' work openings through the compartment walls and floors surrounding the pressurised space (e.g. penetrations for building services) must be made good and sealed.
- *Builders' shafts:* if constructed of brick or blockwork, the inside surfaces of shafts used as part of the system should have a smooth rendered finish to ensure low resistance to airflow and provide a good seal against leakage. The shafts must be pressure tested and be proven to have a leakage factor of less than 10 per cent.
- *Correctly sized shafts and ducts:* since most systems use a very basic shaft layout with simple spigot connections to discharge grilles, it is important to size the shafts and ducts for relatively low air velocity to ensure that correct air distribution is achieved at each grille.

- *Ductwork arrangements:* good working practice must be employed in the layout of the ductwork system. The system must be designed for correct operation of the pressurisation system, not simply to fit the building constraints.
- *Position of air intake:* if at roof level, the intake should be positioned so that it is unlikely to be affected by smoke and should be lower than any shaft or duct that may discharge smoke in the event of a fire. Changes to plant layout during construction should not compromise the air intake position.
- *Position of discharge:* for buildings over three stories in height there should be a discharge grille for every three floors.

### *Hazardous areas*

There are other areas within the building where the building control officer could state a requirement for fire-resisting ductwork, for example areas of high fire risk, boiler houses, plant rooms, transformer rooms.

### **2.5.3.3 Methods of fire protection of ductwork**

There are three methods of fire protection related to ductwork systems as given in Approved Document B supported by BS 9999: 2008: *Code of practice for fire safety in the design, management and use of buildings* (BSI, 2008a). These are described in Appendix 2.A4.

### *Fire resistance and BESA DW/144*

It should be noted that ductwork constructed to DW/144: *Specification for Sheet Metal Ductwork* (BESA, 2013a) has no tested fire resistance. General purpose ventilation/air-conditioning ductwork and its ancillary items do not have a fire rating and cannot be either utilised in or converted into a fire-rated ductwork system unless the construction materials of the whole system (including supports and penetration seals) are proven by test and assessment in accordance with BS EN 1366-1: 2014 (BSI, 2014a) or BS 476-24: 1987 (BSI, 1987c).

In the case where galvanised sheet steel ductwork is clad by the application of protective materials, the ductwork construction must be type tested and comply with the protective material manufacturers' recommendations, for example gauge of ductwork, frequency of stiffeners and non-use of low melting point fasteners or rivets. Sealants, gaskets and flexible joints should be as tested at the same time and certified in accordance with BS EN 1366-1: 2014 (BSI, 2014a) or BS 476-24: 1987 (BSI, 1987c) and comply with the manufacturers' recommendations.

Methods of fire protection for galvanised steel ductwork are given in Appendix 2.A4.

### *Design considerations*

Where ducting penetrates a fire wall or barrier, it is usual to install a fire damper that has the same fire rating as the wall itself. An alternative in some circumstances is to use fire-rated ducting provided this does not link two different fire zones. For example, it is not permitted to install fire

dampers in kitchen extract ducting and, once the ducting has left the kitchen area, it will have to be fire rated up to the point of discharge from the building. No openings into the duct will be permitted nor connections to other areas, not even another kitchen.

In instances where ducting links an escape route to an adjacent area, a fusible link fire damper will not be sufficient. There will be the possibility that 'cool' smoke will fail to melt the fusible link and thereby enter the escape route and render it unusable. In these instances an additional mechanism will be required that will close the damper on a signal from the building fire detection system. The dampers may be reopened manually or mechanically. Where the damper is not within easy reach, or where there are a significant number of them, motors will be used. In planning the design, adequate space for the installation and maintenance of these items must be allowed.

It is usual to route ducting along corridors with branches into the treated area, as this has advantages from the point of view of maintenance access, potentially deeper ceiling void, proximity to risers etc. However, where there is a need for a large number of dampers that are released by the fire alarm system, the designer may consider it better to run the ductwork through the treated area in order to reduce the complication and cost of numerous dampers on several branch ducts.

#### *Fire-resisting stability*

Where ductwork is required to be fire resisting, it is classified according to stability, integrity and insulation. Stability is the ability of a duct to stay in place for the specified period of time when exposed to a fire. Ductwork supports must match the stability of the ductwork. This can be achieved by oversizing them or by applying a protective covering. In all cases, fire-resisting ducts and any associated supports shall be installed as tested. Integrity is the ability of the duct to prevent the passage of fire either into or out of the duct. Insulation is usually called for if the building control officer believes that a duct carrying hot smoke may become sufficiently hot to compromise an escape route.

Fire-resisting ductwork can be either single or double skin. Double-skin ducting is used to encase insulation where this is required, though the more usual alternative is to add insulation to a fire-resisting duct. It is important that adequate space is allowed if a duct is to be insulated. Site modifications to fire-resisting ducts are much more difficult than to normal ducting, as the duct and fittings are often manufactured off-site and site changes may well compromise the classification. Any alterations being made to existing ductwork should be installed as tested, with special care being given to any strengthening at compartment boundaries. Any holes needed for pitot tube measuring instruments need to be cut at the manufacturing stage as site drilling is not allowed.

## **2.5.4 Air leakage**

### **2.5.4.1 General**

Air leakage in buildings and ductwork has a critical impact on ventilation and energy performance. Part L of the

Building Regulations (NBS, 2013a) now imposes airtightness requirements for buildings in order to reduce unwanted air infiltration and reduce energy consumption. Once airtightness is increased much more emphasis is needed on the development and durability of ventilation systems to ensure that air quality is not compromised.

### **2.5.4.2 Duct leakage**

Leakage from ducted air distribution systems is an important consideration in the design and operation of ventilation and air-conditioning systems. A ductwork system having air leakage within defined limits will ensure that the design characteristics of the system can be maintained. It will also ensure that energy and operational costs are not greater than necessary.

Leakage from sheet metal air ducts occurs at the seams and joints and is therefore proportional to the total surface area of the ductwork in the system. The level of leakage is similarly related to the air pressure in the duct system and, whilst there is no precise formula for calculating the level of air loss, it is generally accepted that leakage will increase in proportion to pressure to the power of 0.65.

The effect of air leakage from high-pressure ductwork is critical in terms of system performance, energy consumption and the risk of high frequency noise associated with leakage. These problems are less critical with medium-pressure systems, but should be considered. Low-pressure ducts present the lowest risk in terms of the effect of leakage on the effective operation of the system.

It is important that ductwork should be made as airtight as possible. Conventional sheet metal ductwork is formed by seaming sheets and jointing sections; these seams and joints, penetrations made by damper spindles, control sensors, test holes, access doors etc., all give rise to air leakage. The designer should accept that some leakage will occur in conventional ductwork and make an assessment of the acceptable level in a given system. In some cases it may not be important, for example for a general extract system where the ducting is all in the space being served. In others it may be very important, for example where obnoxious or hazardous contamination is being handled. In the latter case, a completely airtight system may be necessary, where fully welded ducting with air-tight enclosures at all penetrations could be the basis of a special specification, outside the scope of DW/144: *Specification for Sheet Metal Ductwork* (BESA, 2013a).

For most ventilating and air-conditioning applications, compliance with the construction and sealing requirements of DW/144 (BESA, 2013a) will ensure acceptably low leakage rates. For sheet metal ductwork, the specification requires sealant to be applied to all longitudinal seams (except spirally wound, machine-made seams) and cross-joints; for plastic and resin bonded glass fibre ductwork, similar sealing requirements are specified. The sheet metal specification also gives details of an air leakage test procedure. Recommended acceptable leakage rates in  $l \cdot s^{-1} / m^2$  of surface area are given in Table 2.32.

Appendix 2.A3 shows these limits for a range of duct static pressure differentials. These rates are in accordance with the comparable classes in BS EN 12237: 2003: *Ventilation for buildings. Ductwork. Strength and leakage of circular sheet metal ducts* (BSI, 2003a) and BS EN 1507: 2006: *Ventilation*

for buildings. Sheet metal air ducts with rectangular section. Requirements for strength and leakage (BSI, 2006a) but these European Standards do not cover the full range of high-pressure ductwork.

Whilst leakage occurs at seams, joints and penetrations, the purpose of giving acceptable leakage rates in terms of surface area of ductwork is to require that the airtightness is of a consistent standard for air leakage test systems. It does not follow that the total leakage of a system that meets specified leakage requirements will always be a set percentage of the total flow rate; the percentage leakage from short runs can be substantially less than that from long runs. The design therefore plays a very important part in the likely total leakage loss from ductwork systems, since long runs not only provide more crackage and penetration, but also require higher working pressures to operate. Where limitation of air leakage is important, the designer should first ensure that the duct runs are as short as possible, that the operating pressure is as low as possible, that the number of seams, joints and penetrations is kept to a minimum and that there is adequate room around the ducts for site-made joints to be effectively sealed.

Items of equipment and plant installed in ductwork systems can also leak, and particular attention should be paid to the sealing of these items. Where leakage testing is required, the designer should ensure that suppliers of these items can demonstrate that their equipment meets the required airtightness standards. The designer should make adequate allowance in the fan selection for some air leakage so that the completed installation can meet its intended purpose without subsequent adjustments to the fan(s) and motor(s). Table 2.15 gives some recommendations for margins that should be included for complete installations (i.e. ductwork and equipment).

**System leakage loss**

There is no direct relationship between the volume of air conveyed and the surface area of the ductwork system. It is therefore difficult to express air leakage as a percentage of total air volume. Operating pressure will vary throughout the system and, since leakage is related to pressure, the calculations are complex. However, it is generally accepted that, in typical good-quality systems, the leakage from each class of duct under operating conditions will be in the region of:

- low pressure (Class A): 6 per cent
- medium pressure (Class B): 3 per cent
- high pressure (Class C): 2 per cent.

**Table 2.32** Ductwork air leakage limits

Ductwork pressure class	Air leakage limits / l·s <sup>-1</sup> per m <sup>2</sup> of duct surface area
Low pressure (Class A)	0.027 × p <sup>0.65</sup>
Medium pressure (Class B)	0.009 × p <sup>0.65</sup>
High pressure (Class C)	0.003 × p <sup>0.65</sup>
High pressure (Class D)	0.001 × p <sup>0.65</sup>

Note: p = differential pressure / Pa

**Designer’s calculations**

The designer can calculate with reasonable accuracy the predicted total loss from a system by:

- (a) calculating the operating pressure in each section of the system
- (b) calculating the surface area of the ductwork in each corresponding pressure section
- (c) calculating the allowable loss at the operating pressure for each section of the system (see above for indicative leakage figures).

This is illustrated in the duct sizing example shown in Appendix 2.A5.

**Variable pressures in systems**

Designers can achieve significant cost savings by matching operating pressures throughout the system to constructional standards and appropriate air leakage testing. The practice of specifying construction standards for whole duct systems based on fan discharge pressures may incur unnecessary costs on a project.

For example, some large systems could well be classified for leakage limits as follows:

- plant room risers: Class C
- main floor distribution: Class B
- low-pressure outlets: Class A.

**2.5.4.3 Duct air leakage testing**

**General**

It is normal practice for leak testing to be a requirement for all or part of high-pressure ductwork installations, but it is not a regular practice for medium- or low-pressure ductwork installations. It is recommended as good practice that all ductwork installations of significant size (e.g. with a fan capacity greater than 1 m<sup>3</sup>·s<sup>-1</sup>) should be leak tested in accordance with DW/143: *Guide to Good Practice: Ductwork Air Leakage Testing* (BESA, 2013b). It should be noted that air leakage testing of low- and medium-pressure ductwork is not obligatory under DW/144: *Specification for Sheet Metal Ductwork* (BESA, 2013a); this will therefore be an individual contractual matter. However, in the case of low- and medium-pressure ductwork, the relevant country’s Building Regulations should be checked for additional requirements.

Factors that should be taken into account in deciding whether leak testing of all or part of a ductwork installation is necessary are:

- whether adequate supervision of the installation can be provided and whether a final detailed examination of the system is feasible
- whether some sections need to be checked, because access will be impracticable after the installation is complete
- safety hazards that may arise from leakage of contaminated air

This publication is supplied by CIBSE for the sole use of the person making the download. The content remains the copyright of CIBSE.

- whether special circumstances make necessary more stringent control of leakage than is given in the existing specification
- the cost to the client of the leakage testing and the delays caused to the completion of the installation.

The need for leak testing and the extent to which it is carried out should be assessed and, if judged to be necessary, this requirement and its extent should be included in the designer's ductwork specification.

Where it is decided that leak testing is required as part of the commissioning process, the ductwork designer should specify which sections of the ductwork system should be tested and the test pressures and leakage criteria for those sections. DW/144: *Specification for Sheet Metal Ductwork* (BESA, 2013a) describes an appropriate leak testing procedure and gives test pressures and leakage criteria appropriate to high-, medium- and low-pressure ductwork. These leakage rates are given in Appendix 2.A3.

To ensure that the ductwork is sufficiently airtight for the needs of the design, it is recommended that:

- ductwork is sealed in accordance with the design and construction specification
- a visual check is made during erection, with particular attention to site-made joints
- where leakage testing is required, the ductwork is tested in sections as the work proceeds, and the measured air leakage rate for each section checked against the leakage criterion (the sections so chosen should be sufficiently large that the maximum permitted leakage from the sections can be accurately measured with the test equipment)
- joints between test sections that need to be remade can be visually checked
- non-ductwork items (such as attenuators, coils, fire dampers) should be visually inspected, as the leakage from these is not covered by the relevant BESA specification.

Ductwork constructed and installed in accordance with DW/144 (BESA, 2013a) should provide a level of air leakage that is appropriate to the operating static air pressure in the system. However, the environment in which systems are installed is not always conducive to achieving a predictable level of air leakage; it is therefore accepted that designers may require the systems to be tested in part or in total.

It should be recognised that the testing of duct systems adds a significant cost to the installation and incurs some extra time within the programme.

#### Duct pressure

Ductwork constructed to DW/144 (BESA, 2013a) will be manufactured to a structural standard that is compatible with the system operating pressure, i.e. Classes A, B, C and D.

#### Specifying air leakage testing

As previously stated, it is recommended as good practice (and now required by UK Part L legislation) that all

significant installations (e.g. with a fan capacity greater than  $1 \text{ m}^3\text{s}^{-1}$ ) should be tested in accordance with DW/143: *Guide to Good Practice: Ductwork Air Leakage Testing* (BESA, 2013b).

Respecting both the cost and programme implications associated with testing ducts for leakage, the designer may, for example, indicate that a particular system is tested as follows:

- high-pressure ducts: all ductwork to be tested.
- medium-pressure ducts: 10 per cent of the ductwork to be selected at random and tested
- low-pressure: ductwork does not need to be tested.

In the case where a random test is selected for medium-pressure ducts, the following clause from DW/144 (BESA, 2013a) is suggested for inclusion by the designer:

**The designer** shall select at random a maximum of 10 per cent of the duct system to be tested for air leakage. The duct shall be tested at the pressure recommended in Table 22 of DW/144 for the classification for the section of the ductwork that is to be tested.

**The tests** shall be carried out as the work proceeds and prior to the application of thermal insulation. In the event of test failure of the randomly selected section, the system designer shall have the right to select two further sections at random for testing. Where successive failures are identified there shall be a right to require the contractor to apply remedial attention to the complete ductwork system.

**The ductwork** contractor shall provide documented evidence of the calculations used to arrive at the allowable loss for the section to be tested and the client, or his agent, shall witness and sign the results of the test.

#### Special cases

There may be situations where special consideration needs to be given to containing air losses, for example a long run of ductwork may incur a disproportionate level of air loss. In such cases the designer can specify an improved standard of airtightness, for example 80 per cent of allowable loss for Class B ducts. The designer should not specify a Class C test at Class C pressure for a Class B duct. For more information refer to section A6 of DW/144: *Specification for Sheet Metal Ductwork* (BESA, 2013a).

#### Testing of plant items

Items of in-line plant will not normally be included in an air leakage test. The ductwork installation contractor may include such items in the test if the equipment has a certificate of conformity for the pressure class and air leakage classification for the system under test.

### 2.5.4.4 Building and component leakage

#### Introduction

Airtightness requirements for building are covered by Building Regulations. Testing usually requires a whole-building pressurisation test to determine the air leakage at a reference pressure of 50 Pa. This is the average pressure between the inside and outside of the building. The conduction of the test is covered by a protocol as described

in CIBSE TM23: *Testing buildings for air leakage* (2000c) and by the Air Tightness Testing and Measurement Association (ATTMA, 2010). The 50 Pa reference pressure is selected on the basis that results will not be adversely affected by wind and stack pressures under calm conditions but it is not sufficiently high for the generated pressure itself to distort leakage openings physically (either by opening or closing them). Despite this, there is invariably a difference in results between pressurising and depressurising a building as a consequence of the behaviour of leaks.

#### *Whole-building leakage testing by fan pressurisation*

Measurements are made using a 'blower door' (see Figure 2.36(a)) or, in the case of very large buildings, a 'trailer fan' (Figure 2.36(b)) to create incremental pressure differences between the inside and outside of a building in the  $\pm 100$  Pa pressure range. For each pressure increment, the corresponding airflow rate through the fan is measured. The relationship between induced pressure and flow rate is then plotted. From this the air leakage rate at 50 Pa is determined by interpolation as well as the pressure flow characteristics. The flow characteristics are commonly described by the power law equation, as described in CIBSE Guide A (2015a).

By carrying out multiple pressure tests between zones, the airtightness of individual rooms and leakage across party walls can be determined.

#### *Whole-building leakage testing using building HVAC system*

Testing has sometimes been conducted using the building's own HVAC system. In this case the building is pressurised using the building supply fans. Return air and extract fans are switched off and all dampers are closed.

#### *Component airtightness testing*

The air leakage of individual components may also be measured by pressurisation. Sometimes this is undertaken by the manufacturer to check compliance for rain penetration. In this case the component is installed in a test rig such that the pressure difference can be created across the component and the leakage versus airflow rate measured. Components can also be tested in situ by constructing a pressure chamber across the component.

## 2.6 Equipment

### 2.6.1 Fans

#### 2.6.1.1 General

Fans consume a large proportion of the total energy in mechanically ventilated buildings. A high priority should therefore be given to achieving energy-efficient fan operation. To achieve this there is a wide selection of fan types, each of which is designed to perform specific functions. Fan selection is critical for ensuring the correct performance of mechanical ventilation systems. Consideration must be given to optimum fan flow volume rates and the minimisation of pressure drops as outlined in

section 2.3.2.3 and in CIBSE Guide F (2012). Fan types and characteristics are considered in this section.

#### 2.6.1.2 Fan types and components

Table 2.33 provides a summary of fan types.

The following definitions should be used in relation to fans.

- *Casing*: those stationary parts of the fan that guide air to and from the impeller.
- *Guide vanes*: a set of stationary vanes, usually radial, on the inlet or discharge side of the impeller, covering the swept annulus of the impeller blades (or wings). Their purpose is to improve the recovery of the energy contained in the helical whirl of the airstream and thus raise the performance and efficiency of the fan. Inlet guide vanes are intended to pre-rotate the air entering the impeller and therefore alter the performance of the fan.
- *Impeller*: that part of a fan that, by its rotation, imparts movement to the air.

#### *Important fan types*

##### (a) Axial-flow fans





Axial-flow fans comprise an impeller with a number of blades, usually of aerofoil cross section, operating in a cylindrical casing. The fineness of the tip clearance between impeller blades and casing has a marked effect on the pressure development of the fan and, in turn, its output and efficiency. The blades may also have 'twist', i.e. the pitch angle increases from tip to root to equalise the work done along the blade length. As the pitch angle is increased, flow rate and impeller power demand increase. The tendency for flow separation from the blade surface (stall condition) also increases, limiting the maximum operating pressure. The hub is used to support the blades, generally incorporates a means of adjusting the blade angle and acts as a fairing for the motor. Large hubs and short blades characterise a high pressure-to-volume ratio and vice versa. Refinements include guide vanes to correct whirl at inlet or discharge and fairings and expanders to recover a greater proportion of the velocity head in the blade swept annulus.

Axial-flow fans are of high efficiency and have limiting power characteristics, but as the highest pressure single-stage axial-flow fans develop only about one fifth of the pressure produced by a forward-curved (multi-vane) fan, they are best suited for high-volume/pressure ratios. However, axial-flow fans may be staged or placed in series and when fitted with guide vanes the aggregate pressure developed is proportional to the number of stages for a given volume. A two-stage fan can be contra-rotating, and without the use of guide vanes the pressure developed may be up to 2.75 times greater than that of a single stage.

##### (b) Centrifugal fans

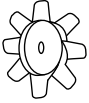
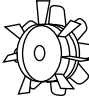
Centrifugal fans comprise an impeller that may (depending on type and application) rotate in a diffusing casing that has an expanding radial dimension (referred to as a volute or scroll casing). The air flows into the impeller axially, turns through a right angle within it and is discharged radially by centrifugal force. The scroll acts as a collector

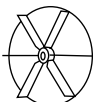
Table 2.33 Summary of fan types

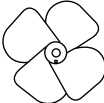
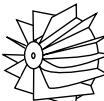
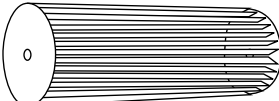
Fan type	Efficiency / %		Advantages	Disadvantages	Applications
	Static	Total			
1. Axial-flow (without guide vanes) 	50–65	50–75	Very compact, straight-through flow. Suitable for installing in any position in run of ducting.	High tip speed. Relatively high noise level comparable with type 5. Low-pressure development.	All low-pressure atmospheric air applications.
2. Axial-flow (with guide vanes) 	65–75	65–85	Straight-through flow. Suitable for vertical axis.	Same as type 1 but to lesser extent.	As for type 1, and large ventilation schemes such as tunnel ventilation.
3. Forward-curved or multivane centrifugal 	45–60	45–70	Operates with low peripheral speed. Quiet and compact.	Severely rising power characteristic requires large motor margin.	All low- and medium-pressure atmospheric air and ventilation plants.
4. Straight or paddle-bladed centrifugal 	45–55	45–70 60 (non-shrouded)	Strong, simple impeller. Least likely to clog. Easily cleaned and repaired.	Low efficiency. Rising power characteristic.	Material transport systems and any application where dust burden is high.
5. Backwards-curved or backwards-inclined blade centrifugal 	65–75	65–85	Good efficiency. Non-overloading power characteristic.	High tip speed. Relatively high noise level compared with type 3.	Medium- and high-pressure applications such as high-velocity ventilation schemes.
6. Aerofoil-bladed centrifugal 	80–85	80–90	Highest efficiency of all fan types. Non-overloading fan characteristic	Same as type 5.	Same as type 5 but higher efficiency justifies use for higher power applications.
7. Propeller 	<40	<40	Low first cost and ease of installation.	Low efficiency and very low pressure development.	Mainly non-ducted low-pressure atmospheric air applications. Pressure development can be increased by diaphragm mounting.
8. Mixed-flow 	45–70	45–70	Straight-through flow. Suitable for installing in any position in run of ducting. Can be used for higher pressure duties than type 2. Lower blade speeds than types 1 or 2, hence lower noise.	Stator vanes are generally highly loaded due to higher pressure ratios. Maximum casing diameter is greater than either inlet or outlet diameters.	Large ventilation schemes where the higher pressures developed and lower noise levels give an advantage over type 2.
9. Cross-flow or tangential-flow 	—	40–50	Straight across flow. Long, narrow discharge.	Low efficiency. Very low pressure development.	Fan coil units. Room conditioners. Domestic heaters.

that permits vortex flow to the casing outlet and converts some of the high velocity pressure at the blade tips into static pressure. There are several variations of the basic form (see below) and the impellers may be arranged as single-inlet types or double-inlet, double-width types (DIDW), essentially two single inlet impellers running back to back in parallel.

- *Forward-curved or multi-vane:* the impeller has a relatively large number of short, forward-curved blades. The air is impelled forward in the direction of rotation at a speed greater than the impeller tip speed. For a given duty, this type of fan is the smallest and least noisy of the centrifugal types. It operates with the lowest tip speed and is often referred to as a low-speed fan. As the velocity of the air does not decrease within the blade passages, the efficiency is not high (although it is generally equivalent to other types at low operating pressures) and the motor can easily be overloaded if the system resistance is overestimated (i.e. the fan power increases as system resistance is decreased). This type can only be used within a scroll housing.
- *Straight-radial or paddle-blade:* the impeller has a few (typically six) straight blades, which may be fixed by the roots to a spider or may have a back-plate and shroud-plate. This is the simplest, and least efficient of fan types but is well suited to applications where airborne material is present, as the blades are unlikely to clog. The impeller is of high mechanical strength and is cheap to refurbish. Renewable blades or wear plates are often fitted.
- *Backwards-curved blade:* the air leaves the impeller at a speed less than the impeller tip speed and the rotational speed for a given duty is relatively high. The impeller has from 10 to 16 blades of curved or straight form, inclined away from the direction of rotation. Because the blades are deep, good expansion within the blade passages takes place and this, coupled with a relatively low air speed leaving the impeller, ensures high efficiency and a non-limiting power characteristic. This fan type may be operated without a scroll diffuser and has become popular for AHU applications as a 'plug' fan, where its compact axial dimensions are beneficial.
- *Aerofoil blade:* a refinement of the backwards-curved fan in which the impeller blades are of aerofoil contour with a venturi throat inlet and fine running clearance between inlet and impeller. The casing is compact and the volumetric output is high. It has the highest static efficiency but is a relatively high-speed fan due to the low-pressure development.

### (c) Propeller fans

Propeller fans comprise an impeller of two or more blades of constant thickness, usually of sheet steel, fixed to a centre boss and are designed for orifice or diaphragm mounting. They have high volumetric capacity at free delivery but very low-pressure development. However, this may be increased by fitting the fan in a diaphragm, which in turn may be installed in a circular or rectangular duct of area greater than the blade-swept area. The conventional efficiency of propeller fans is low, but in their typical application of moving air across a partition, their specific fan power may be acceptable.

### (d) Cross-flow or tangential fans

These resemble a forward-curved centrifugal type impeller but with greatly increased blade length and the conventional inlets blocked off. The impeller runs in a half casing with conventional discharge but no inlet. Air is scooped inwards through the blade passages on the free side, but at the opposite side of the impeller, due to the influence of the casing, the air obeys the normal centrifugal force and flows out of the impeller and through the fan discharge.

The principle of operation relies on the setting up of a long cylindrical vortex stabilised within the impeller, which, being much smaller in diameter than the impeller, rotates at high angular velocity. This in turn drives the main airstream past the blades of the fan with higher velocity than the peripheral speed of the blades themselves. In effect the air flows 'across' the impeller, almost at right angles to the axis. Because this fan is so different from other types, direct comparisons are not valid. A serious disadvantage of this type is that it cannot be operated at shaft speeds widely different from that for which it has been designed. Consequently it obeys the fan laws only within narrow limits of speed change. It operates with a high discharge velocity and an expander is desirable when connected to ductwork, especially as the efficiency (which is rather less than that for the multi-vane fan) peaks at near-free delivery conditions. The discharge opening is characteristically narrow so the fan is not easily applicable to ducting but is well suited to fan coil units and electric space heaters.

### (e) Mixed-flow in-line fans

Mixed-flow fans comprise an impeller with a number of blades, often of aerofoil section, similar to the axial flow fan. The hub is of conical shape such that the passage of air through the impeller has both axial and radial components, hence the term 'mixed flow'. Mixed-flow fans are of high efficiency and can be designed for higher pressure duties than axial flow fans. To remove the swirl generated by the passage of air through the impeller, stator guide vanes are fitted downstream. These vanes are generally highly loaded due to the high-pressure ratios. If the inlet and outlet flanges are to be of the same diameter, a change in casing profile is necessary in the region of the guide vanes. Separation of airflow can occur if the conditions for which the fan was designed are not maintained in practice.

### (f) Bifurcated fans

Bifurcated fans handle atmospheres normally detrimental to the life of the fan motor, including saturated and dust-laden atmospheres, heated air, hot gases and corrosive fumes. They are normally direct drive with the motor isolated from the system airstream. These fans are generally of the axial flow type, but similar 'motor out of airstream' concepts are well established for centrifugal types.

## 2.6.1.3 Fan performance

### Definition of terms

Fan performance is expressed in terms of fan size, air delivery, pressure, speed and power input at a given air density. Efficiency will be implied or specifically expressed. The size of a fan depends on the individual manufacturer's coding but is generally expressed as, or is a function of,

either the inlet diameter or the impeller diameter. Other terms are defined in BS EN ISO 5801: 2008: *Industrial fans. Performance testing using standardized airways* (BSI, 2008c) and BS EN ISO 13349: 2010: *Fans. Vocabulary and definitions of categories* (BSI, 2010c).

- *Standard air*: for the purposes of rating fan performance, reference air is taken as having a density of  $1.200 \text{ kg}\cdot\text{m}^{-3}$ ; this value corresponds to atmospheric air at a temperature of 293.15 K, a pressure of 101.325 kPa, relative humidity of 40 per cent and a gas constant ( $R_w$ ) of 288 J/kg·K (section 12.1 of BS EN ISO 5801: 2008 (BSI, 2008c)).
- *Fan inlet area* ( $A_1$ ): the surface plane bounded by the upstream extremity of the air-moving device. *Note*: fan inlet area is, by convention, taken as the gross area in the inlet plane inside the casing.
- *Fan outlet area* ( $A_2$ ): the surface plane bounded by the downstream extremity of the air-moving device. *Note*: fan outlet area is, by convention, taken as the gross area in the outlet plane inside the casing.
- *Fan pressure* ( $p_f$ ): the difference between the stagnation pressure at the fan outlet ( $p_{sg2}$ ) and the stagnation pressure at the fan inlet ( $p_{sg1}$ ) given by the equation:

$$p_f = p_{sg2} - p_{sg1} \quad (2.21)$$

*Note*: when the Mach number is less than 0.15, it is possible to use the relationship:

$$p_f = p_{tf} = p_{t2} - p_{t1} \quad (2.22)$$

where  $p_{tf}$  is the fan total pressure.

*Note*: it is possible to refer the fan pressure to the installation category A, B, C or D (see below).

- *Stagnation pressure at a point* ( $p_{sg}$ ): pressure that would be measured at a point in a flowing gas if it were brought to rest via an isentropic process.

*Note*:  $Ma$  is the Mach number at this point; for Mach numbers less than 0.122 obtained for standard air with duct velocities less than  $40 \text{ m}\cdot\text{s}^{-1}$ , the stagnation pressure is virtually the same as the total pressure.

- *Dynamic pressure at the fan outlet* ( $p_{d2}$ ): conventional dynamic pressure at the fan outlet calculated from the mass flow rate ( $q_m$ ), the average gas density at the outlet and the fan outlet area:

$$p_{d2} = \rho_2 \frac{v_{m2}^2}{2} = \frac{1}{2\rho_2} \left( \frac{q_m}{A_2} \right)^2 \quad (2.23)$$

- *Fan static pressure* ( $p_{sf}$ ): this is defined as the fan pressure minus the fan dynamic pressure corrected by the Mach factor ( $f_{M2}$ ) as given by the following equation:

$$p_{sf} = p_{sg2} - p_{d2} f_{M2} - p_{sg1} = p_2 - p_{sg1} \quad (2.24)$$

*Note*: it is possible to refer the fan static pressure to the installation category A, B, C or D (see below).

- *Inlet volume flow rate*: the methods of flow measurement in this International Standard lead to a determination of the mass flow rate ( $q_m$ ). In the absence of leakage,  $q_m$  is constant throughout the airway system. The inlet volume flow rate can be expressed as the volume flow rate under inlet stagnation conditions, i.e.:

$$q_{Vsg1} = \frac{q_m}{\rho_{sg1}} \quad (2.25)$$

where:

$$\rho_{sg1} = \frac{p_{sg1}}{R_w \Theta_{sg1}} \quad (2.26)$$

where  $\Theta$  is absolute temperature.

- *Fan air power* ( $P_u$ ): the product of the inlet volume flow rate ( $q_{Vsg1}$ ), the compressibility coefficient ( $k_p$ ) and the fan pressure ( $p_f$ ) given by the following equation:

$$P_u = q_m W_m = q_{Vsg1} p_f k_p \quad (2.27)$$

where  $W_m$  is fan (static) work per unit mass.

*Note*: it is possible to refer the fan air power to the installation category A, B, C or D (see below); fan air power is expressed in watts when  $q_m$  is in  $\text{kg}\cdot\text{s}^{-1}$  and  $W_m$  is in  $\text{J}\cdot\text{kg}^{-1}$ ; fan air power is expressed in watts when  $q_{Vsg1}$  is in  $\text{m}^3\cdot\text{s}^{-1}$  and  $p_f$  is in Pa.

- *Fan static air power* ( $P_{us}$ ): the product of the inlet volume flow rate ( $q_{Vsg1}$ ), the compressibility coefficient ( $k_{ps}$ ) and the fan static pressure ( $p_{sf}$ );  $k_{ps}$  is calculated using  $r = p_2/p_{sg1}$ :

$$P_{us} = q_m W_m = q_{Vsg1} k_{ps} p_s \quad (2.28)$$

*Note*: it is possible to refer the fan static air power to the installation category A, B, C or D (see below); the fan static air power is expressed in watts when  $q_m$  is in  $\text{kg}\cdot\text{s}^{-1}$  and  $W_m$  is in  $\text{J}\cdot\text{kg}^{-1}$ .

- *Impeller power* ( $P_r$ ): the mechanical power supplied to the fan impeller, expressed in watts.
- *Fan shaft power* ( $P_a$ ): the mechanical power supplied to the fan shaft, expressed in watts.
- *Motor output power* ( $P_o$ ): the shaft power output of the motor or other prime mover, expressed in watts.
- *Motor input power* ( $P_e$ ): the electrical power supplied at the terminals of an electric motor drive, expressed in watts.
- *Fan impeller efficiency* ( $\eta_r$ ): this is defined as fan air power ( $P_u$ ) divided by the impeller power ( $P_r$ ) as follows:

$$\eta_r = \frac{P_u}{P_r} \quad (2.29)$$

*Note*: it is possible to refer the fan impeller efficiency to the installation category A, B, C or D (see below); fan impeller efficiency may be expressed either as a proportion of unity or as a percentage.

- *Fan impeller static efficiency* ( $\eta_{sr}$ ): this is defined as the fan static power divided by the impeller power, given by the equation:

$$\eta_{sr} = \frac{P_{us}}{P_r} \quad (2.30)$$

*Note:* it is possible to refer the fan impeller static efficiency to the installation category A, B, C or D (see below); fan impeller static efficiency may be expressed as a proportion of unity or as a percentage.

- *Fan shaft efficiency* ( $\eta_a$ ): this is defined as the fan air power divided by the fan shaft power given by the equation:

$$\eta_a = \frac{P_u}{P_a} \quad (2.31)$$

*Note:* fan shaft power includes bearing losses, while fan impeller power does not; it is possible to refer the fan shaft efficiency to the installation category A, B, C or D (see below); fan shaft efficiency may be expressed as a proportion of unity or as a percentage.

- *Fan motor shaft efficiency* ( $\eta_o$ ): this is defined as the fan air power  $P_u$  divided by the motor output power  $P_o$  as given by the equation:

$$\eta_o = \frac{P_u}{P_o} \quad (2.32)$$

*Note:* it is possible to refer the fan motor shaft efficiency to the installation category A, B, C or D (see below); fan motor shaft efficiency may be expressed as a proportion of unity or as a percentage.

#### 2.6.1.4 Fan installation category

According to BS EN ISO 5801: 2008: *Industrial fans. Performance testing using standardized airways* (BSI, 2008c), fans should be tested using a method that is to some extent representative of their intended installation type. The standard contains extensive definitions of the various test ductwork arrangements, and the difference in performance levels achieved can be considerable, and should be included in any assessment of fan suitability.

The four categories of installation are as follows:

- *category A:* free inlet, free outlet
- *category B:* free inlet, ducted outlet
- *category C:* ducted inlet, free outlet
- *category D:* ducted inlet, ducted outlet.

In the above classification, the terms should be taken to have the following meanings. Free inlet or outlet signifies that the air enters or leaves the fan directly from or into the unobstructed free atmosphere. Ducted inlet or outlet signifies that the air enters or leaves the fan through a duct directly connected to the fan inlet or outlet respectively.

#### 2.6.1.5 Fan efficiency

The various definitions of impeller efficiency given in the section on terminology (section 2.6.1.3), demonstrate that

it is always important to identify the precise scope of the term being considered. This has become a pertinent issue, as the need to identify, quantify and verify products in terms of their energy efficiency has become very important. The Ecodesign of Energy-using Products (EuP) Directive 2005/32/EC (EC, 2005) was recast as the ErP (Ecodesign of Energy-related Products) Directive 2009/125/EC (EC, 2009), expanding its scope from products that require energy to perform their primary function to include products that influence energy use. The European government has sought to apply energy-labelling schemes (Energy Labelling Directive 92/75/EEC (EC, 1992)) to a wider variety of products, and fans are now included in this exercise.

Because of the wide variety of fan types and their specific operating characteristics, there has been a great deal of work necessary to establish fan product groups and then to determine appropriate efficiency measures and levels for each type. The approach that has been adopted is to consider each fan type when operating at its peak efficiency point. (On a fan performance curve, there is one operating point that corresponds to the intended design conditions — for all other duty points the fan efficiency levels are not optimised.)

There are also issues of physical scale to be considered, as impeller details such as blade thickness and running clearances do necessarily scale with the principal dimensions of the impeller. This generally means that larger impellers are more efficient.

The result of this exercise has been to establish a range of fan/motor efficiency grades (FMEG) appropriate to each fan type, which are related to the fan input power (BSI, 2015c). The grades are applicable to fans with input powers in the range 0.125 kW to 500 kW. The minimum efficiency target when plotted against fan input power is constructed such that two curves are defined for the ranges 0.125–10 kW and >10–500 kW. Depending on the fan type and the appropriate installation category, efficiency grades may be based on static or total pressures. The FMEG came into effect in the EU from 2013.

An example efficiency curve set is illustrated in Figure 2.38.

The work has led to the publication of BS EN ISO 12759: 2015: *Fans. Efficiency classification for fans* (BSI, 2015c), which specifies:

‘requirements for classification of fan efficiency for all fan types driven by motors with an electrical input power range from 0.125 kW to 500 kW. It is applicable to (bare shaft and driven) fans, as well as fans integrated into products. Fans integrated into products can be measured as stand-alone fans.’

#### 2.6.1.6 The fan laws

For a given system in which *the total pressure loss is proportional to the square of the volume flow*, the performance of a given fan at any changed speed is obtained by applying the following three rules (the air density is considered unchanged throughout).

- *Rule 1:* The inlet volume varies directly as the fan speed.

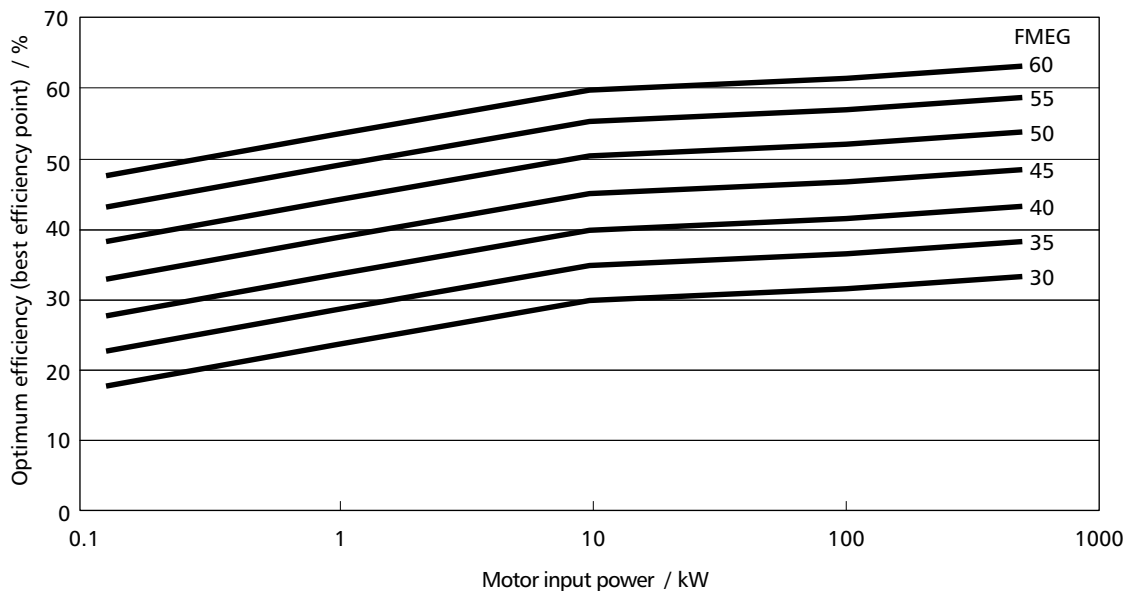

Figure 2.38 Efficiency curves for different fan/motor efficiency grades

- **Rule 2:** The fan total pressure and the fan static pressure vary as the square of the fan speed.
- **Rule 3:** The air power (total or static) and impeller power vary as the cube of the fan speed.

It should be noted that the pressure loss characteristics of several common system element types (e.g. filters, heat exchangers) do not conform to this pattern. Where such elements represent a significant proportion of the overall system resistance, use of these calculations can lead to inaccurate results.

For changes in density the following rule is applied.

- **Rule 4:** The fan total pressure, the fan static pressure and the fan power all vary directly as the mass per unit volume of the air, which in turn varies directly as the barometric pressure and inversely as the absolute temperature.

For geometrically similar airways and fans operating at constant speed and efficiency the performance is obtained by applying the following three rules (the air density is considered unchanged throughout).

- **Rule 5:** The inlet flow rate varies as the cube of the fan size.
- **Rule 6:** The fan total pressure and the fan static pressure vary as the square of the fan size.
- **Rule 7:** The air power (total or static) and impeller power vary as the fifth power of the fan size.

## 2.6.2 Air control units

### 2.6.2.1 General

Fans consume a large proportion of the total energy in mechanically ventilated buildings. A high priority should therefore be given to achieving energy-efficient fan operation. Fan volumes and pressure drops should be minimised by good design. Benchmarks for fan volumes and pressure drops are provided in CIBSE Guide F (2012).

The two approaches used to regulate the amount of energy used by fans (within the EU), have their basis in the Energy Performance in Buildings Directive (2002/91/EC) (EC, 2002) and the EuP Directive 2009/125/EC (EC, 2009).

The specific fan power (SFP) is a measure of ventilation system performance that unifies the various elements of system design and has been widely adopted in regulations. It integrates the effects of active components such as fans and AHUs, and the passive (in airflow terms) elements such as filters and ducting.

The calculation methods and uses of SFP in ventilation system design and validation are extensively covered in European standards, for example BS EN 13779: 2007: *Ventilation for non-residential buildings. Performance requirements for ventilation and room-conditioning systems* (BSI, 2007a).

In its simplest form, the SFP is the result of dividing the total input power to the ventilation system (i.e. including the loads due to controls and ancillary items) by the delivered air volume flow rate and may be considered at the unit, zone or building level.

Consideration should be given to over-sizing parts of the system to reduce pressure drops, for example by increasing the AHU cross-sectional area, as components such as heat recovery devices, filters and cooling coils are likely to be responsible for the majority of the losses.

Equipment and ductwork dimensional selections may be optimised for both whole-life cost and minimum energy use, with the resulting designs differing principally in terms of capital costs. Selection should favour the more efficient fan types and try to ensure that the fans will be operating at peak efficiency.

In ventilation systems for spaces where occupancy levels or type of use varies, efficient means of volume flow rate control should be incorporated to meet varying levels of demand. This may be at the dictates of temperature, pressure or air-quality sensors. Flow control may be achieved by a number of means including:

- on/off, multi-speed or variable speed operation

- varying the blade pitch (during operation) for axial fans
- inlet guide vanes.

These types of demand-controlled ventilation can have a very significant effect on the energy required to operate the system — in terms of both fan power and the heating and/or cooling loads. There are additional benefits in terms of reduction in system noise levels, maintenance requirements and improvements in overall system longevity.

Control is particularly needed when various areas to be air conditioned have differing heat gain patterns with respect to time; these can be met from a central plant in which either the temperature or volume (or both) of the air supplied to each area is varied to meet the particular requirements of the area. Such temperature or volume control may be carried out in ductwork serving a number of rooms or zones, or it may be carried out in the terminal units feeding individual rooms.

### 2.6.2.2 Volume flow control

#### *Fan speed control*

Of the methods mentioned, fan speed control is the most widely adopted, and today's ventilation systems have the advantage of the availability of very effective motor control technologies.

Two control families tend to dominate fan applications. First, speed control by variable frequency device (inverter) applied to essentially standard three-phase AC induction motors (suitably rated and constructed). These devices allow a speed control range of approximately 30 to 100 per cent (over-speed operation is also possible where sufficient motor capacity is available) and offer a variety of interface options for building management system (BMS) and other control system integration.

The second and, more recently, popular speed control type is referred to as 'EC' technology in reference to the electronic commutation applied to a high efficiency permanent magnet DC motor. Power supply conversion is generally provided on the motor itself, allowing direct connection to the AC mains supply. Again, a range of interface options is available.

AC induction motor designs have reached good levels of efficiency, particularly in larger sizes, and European legislation (IEC, 2014) for minimum motor efficiency levels extends down to approximately 80 per cent at 0.75 kW. The best EC-type motors are capable of reaching these efficiency levels in motors with output ratings down to approximately 200 W.

It is important for the system designer to understand that control elements (both electrical and mechanical types) have an inherent power conversion efficiency that is less than unity and that their use may also have a detrimental effect on the base motor efficiency.

These effects need to be assessed and compared with the potential energy savings with full knowledge of the modes of system operation.

#### *Mechanical volume controller*

This is a device that is self-actuating and capable of automatically maintaining a constant pre-set volume through it, provided that the pressure drop across it is above a minimum of about 120 Pa and below a maximum of about 250 Pa. As the supply air pressure increases, most devices of this type tend to close progressively by means of a flexible curtain or solid damper — a multi-orifice plate fixed across the complete airway of the unit. As such a unit achieves volume reduction by reducing the airway, there is a tendency to generate noise, particularly when working at high air pressures. For this reason, the volume controller is generally supplied in an acoustically treated terminal unit. It is factory pre-set to pass a specific volume and, when installed, will automatically give a pre-balanced air distribution system up to and including the terminal unit. It can be adjusted on-site, if desired.

#### *Pressure regulating valve*

This is an assembly consisting of one or two rows of shaped blades, the size of which changes when volume adjustment is required. Because of the particular blade shape, the device gives volume adjustment up to pressure drops of about 630 Pa without generating excessive noise.

The majority of dampers are set on-site, but they can be controlled from a static pressure-sensing element. Such units are generally supplied as a separate component for direct installation in the ductwork and not as part of a terminal unit.

#### *Damper control*

A damper is normally of the butterfly or multi-leaf type and capable of controlling the volume, providing the pressure drop across the damper does not exceed about 40 Pa. If the pressure drop is higher, there will be a tendency to generate excessive noise. Normally the damper is supplied as a separate component for direct installation in the ductwork and not as part of a terminal unit. Final adjustment is carried out manually on-site.

Dampers, while essential for airflow balancing in branched systems, waste fan energy and should not generally be used for primary air volume control. See GIR 41: *Variable Flow Control* (Action Energy, 1996) for further information on volume control.

### 2.6.2.3 Control of temperature

The control of temperature may be achieved by:

- *blending*: two separate airstreams, one warm and one cool, are supplied to a zone and mixed in a terminal unit to produce a supply air temperature that offsets the zone cooling or heating loads
- *reheat*: controlled reheat of a pre-conditioned, low temperature air supply by means of hot water, steam or electric coils, may be used to give a resultant supply air temperature that will satisfy the zone requirement.

## 2.6.3 Mixing boxes

A mixing box is a plenum in which recirculated and fresh air are mixed before entering an AHU. It may be part of the ductwork installation, a builder's work chamber or a standard module attached to packaged plant.

Mixing boxes must be designed to provide sufficient mixing so that freezing outside air does not stratify below warm recirculation air on entering the filters. If in doubt, a frost coil at the air intake should be provided. Motorised dampers should be located and set to promote mixing of the airstreams. Parallel blade dampers may assist mixing. Air blenders/baffles can also be used. To improve the range ability of a motorised control damper, the face velocity should be increased to 5–6 m·s<sup>-1</sup> by adjusting the duct size or by blanking off an appropriate area of the duct at the damper. Damper quality is critical; play in linkages and pivots should be minimal and leakage on shut-off should be less than 0.02.

The use of high velocities and the other methods mentioned to promote improved mixing does have consequences in terms of system operating power and of noise generation.

## 2.6.4 Air terminal devices: diffusers and terminals

### 2.6.4.1 Introduction

An air terminal device is needed to ensure the correct discharge of air from a ventilation system into the ventilated space. Air can be supplied to the space in a number of ways (HEVAC, 2015), the principal division being between diffusers and perpendicular jets. Airflow patterns for both types are strongly dependent upon the presence or absence of the Coanda effect (see 'Coanda effect' in section 2.4.3.5). Table 2.34 summarises the types of air terminal devices and provides information on typical face velocities (based on any local control devices being fully open) and noise levels.

The location of terminal devices is also an important consideration. A floor-based supply is usually selected if raised floors are in place as might be common for IT systems. Floor-based systems allow the ceiling mass to be exposed. They may however restrict the furniture layout unless any under-floor units or distribution grilles are designed for easy relocation. Access for maintenance is, in theory, easy. Displacement system diffusers are normally floor based or floor mounted. Alternatively, diffusers may be ceiling based. This allows greater flexibility of furniture layout and also allows heat to be more efficiently extracted from light fittings. Supply terminals may also be incorporated into wall (high or low level), desktop, seat back or under seats. Further guidance can be obtained from HEVAC (2015). Conventional mixing systems are typically ceiling based.

Diffusers may be radial, part-radial or linear and normally utilise the Coanda effect and or/swirl to reduce the risk of excessive room air movement. A perpendicular jet is formed by discharging air through grilles, louvres, nozzles or any opening that allows perpendicular flow. Direction and spread adjustment can be provided using blades and/or swivel adjustment.

### 2.6.4.2 Terminal and diffuser types

Types vary according to need, and it is important to select the correct component. Common types are described in more detail below (REHVA, 2003; Jackman, 1990).

#### *Pure displacement terminals*

Pure displacement terminals aim to get air into the room with a minimum of eddies, room air mixing and temperature pick-up before it reaches the occupants. Hence there is a very small temperature difference between the supply air and that of the occupied zone.

#### *Induction-type diffusers*

Induction-type diffusers are intended to promote various levels of eddy mixing of the room air at the diffuser face. This allows lower supply air temperatures and hence marginally greater displacement cooling capacity. They have a larger approach temperature, generally require some mechanical cooling and impart a higher turbulent intensity with potential discomfort. Induction type diffusers for displacement ventilation require a substantial diffuser open area to obtain low velocities. Without this the discharge, velocity will be too high to support displacement ventilation (see section 2.2.8.2).

#### *Swirl-type diffusers*

Swirl type diffusers introduce air into a space with a swirling rotational discharge. This results in a rapid induction of room air into the primary air stream causing a quicker reduction of primary air velocity and temperature differential than in the case of conventional square or circular diffusers.

## 2.6.5 Ventilation air intake and discharge points

Outdoor air is drawn into a mechanical ventilation system through an air intake and discharged into the atmosphere from the ventilation system through a discharge terminal.

Each intake and discharge point should be protected from the weather by louvres, cowls or similar devices. Any space behind or under louvres or cowls should be 'tanked' and drained if there is a possibility of penetration by, and accumulation of, rain or snow that could stagnate and give rise to unpleasant odours within the building. Bird screens and insert mesh should be used to prevent entry by birds or other large objects. Intake points should be situated to minimise pollution from potential sources (existing and planned) including:

- traffic
- boiler flues and exhausts from standby generators (or combined heat and power engines)
- cooling towers and other heat rejection plant
- vents from plumbing, oil storage tanks etc.
- ventilation exhausts from fume cupboards, kitchens, toilets, car parks, print rooms
- stagnant water (e.g. on flat roofs)

- roosting ledges for birds (droppings can be a source of biological contamination)
- gardens or areas of vegetation (sources of fungal spores or pollen)
- areas where leaves or other litter might accumulate
- radon gas.

Because traffic is generally a ground-level pollutant, there is normally a reduction in pollutant concentration with height, so that concentrations are lower at roof level. Vehicle loading bays can be subject to traffic pollution.

Whilst wet cooling towers give rise to the greatest health concern because of the potential risk of legionella, other heat rejection equipment can also affect system performance by elevating the temperature of the intake air and increasing the cooling demand on the system.

Locating system discharge and intake points close together facilitates the use of some heat-recovery strategies. However, it will also increase the risk of 'short circuiting'. Even extract systems from 'normal' occupied areas will contain pollutants generated by internal sources. These may not represent a health hazard but may still result in an odour nuisance if recirculated. The more remote the intake from the discharge point, the less the risk of short circuiting. Locating the intake and discharge on different façades can also help to reduce the risk. However, wind forces on the two fan systems (which will be balanced for openings on the same façade) may affect fan performance and cause flow instabilities, particularly where fan pressures are low. The influence of wind pressures can be reduced by:

- positioning openings within a zone of minimal pressure fluctuation
- providing balanced openings that face in two or more opposite directions or an omni-directional roof-mounted cowl.

**Table 2.34** Types of air terminal device

Type	Application	Location	Core velocity / m·s <sup>-1</sup>		Description and remarks
			Quiet	Commer- cially quiet	
1. Perforated or stamped lattice	Supply, extract, transfer	Ceiling, side wall, floor	Up to 3	Up to 6	Simple form of grille with small free area. Alternatively can be used as supply diffuser with high air entrainment allowing large quantities to be diffused. For low-level 'laminar flow' panels to give displacement ventilation, a velocity of 0.25 m·s <sup>-1</sup> is used.
2. Aerofoil blades (one row adjustable)	Supply, extract	Ceiling, side wall, desk top	4	8	Frequently used grille with large free area. Directional control in one plane only for supply applications.
3. Aerofoil blades (two rows adjustable)	Supply	Side wall	4	8	As type 2 but with directional control in two planes.
4. Fixed blade	Supply, extract		4	8	Robust grille with limited free area. Some directional control possible using profiled blades.
5. Non-vision	Extract, transfer	Side wall	3	8	Low free area. Designed to prevent through vision.
6. 'Egg crate'	Extract	Ceiling, side wall	4	8	Generally largest free area grille available.
7. Fixed geometry diffusers	Supply, extract	Ceiling, floor, desk top	4	8	Radial discharge diffusers offer good air entrainment allowing diffusion of large air quantities. Square or rectangular diffusers can provide 1-, 2- or 3-way diffusion. Angled blades can be used to apply twisting motion to supply air.
8. Adjustable diffusers	Supply	Ceiling	4	6	As type 7 but offers horizontal or vertical discharge. Can be thermostatically controlled.
9. Slot and discharge, linear diffusers	Supply, extract	Ceiling, side wall, desk top, under window	4	8	Offers vertical or horizontal single or multiple slots. Care must be taken with design of plenum box. Desk top units may incorporate induction of room air.
10. Air handling luminaires	Supply, extract	Ceiling	4	8	As type 9 but single slot only. Normally used in conjunction with extract through luminaire.
11. Ventilated ceiling nozzle	Supply, extract		—	—	Void above ceiling is pressurised to introduce air at low velocity through many single holes or through porous panels. Air entrainment is restricted and natural air currents may affect room air distribution.
12. Nozzles, drum and punkah louvres	Supply	Ceiling, side wall, under window, seat back	—	—	Adjustable type can be rotating drum or swivelling ball, with or without jet for long throws and personal air supply or 'spot' cooling. Fixed multiple nozzles are used for high-induction applications. Velocities depend on throw, noise and induction requirements.

Measures that should be considered to minimise re-entry from contaminated sources include (ASHRAE, 2009):

- grouping exhaust to increase plume rise due to the greater momentum of the combined exhaust
- placing inlets on the roof where wind pressures will not vary greatly with direction to ensure greater stability
- avoiding locating exhaust outlets within enclosures or architectural screens that may hold contaminants within areas of flow recirculation
- discharging exhausts vertically
- locating wall exhausts on the upper third of a façade and intakes on the lower third to take advantage of normal wind separation on a building façade (although consideration should be given to flow recirculation that can occur on a leeward façade)
- avoiding locating inlets and exhausts near edges of walls or roofs due to pressure fluctuations.

Toxic and hazardous exhaust must not be discharged in a manner that will result in environmental pollution. The local authority environmental health officer should be consulted to ensure that the proposed discharges will be acceptable. European Directive 80/779/EEC (EC, 1980) gives mandatory air-quality standards for smoke and sulphur dioxide (see also section 2.2.2). A vertical discharge stack, capable of imparting a high efflux velocity to the exhaust, may be required. If so, provision must be made for handling rainwater and avoiding corrosion. Industrial processes resulting in polluting emissions to air, water or land come under the requirements of the Environmental Protection Act (HMSO, 1990). CIBSE Guide A (2015a) provides guideline values for pollutants. Reference should also be made to CIBSE TM21: *Minimising pollution at air intakes* (1999) for more detailed guidance on pollution sources and assessment methods.

## 2.6.6 Process exhaust hoods

### 2.6.6.1 General

Exhaust hoods are required to collect stale or contaminated air from processes for safe discharge into the atmosphere.

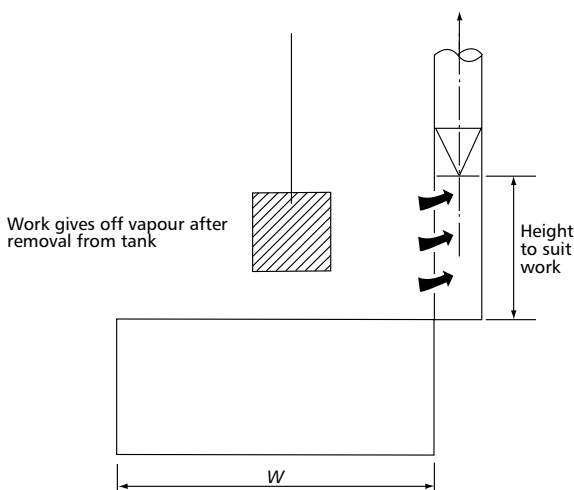

Figure 2.39 Open surface tank with drying facility, single side exhaust

In the case of chemical or biological contamination, cleaning and filtration of the exhaust will be necessary.

Typical examples of extract hood are illustrated in Table 2.35 below. For each hood the table also gives the equations for air volume flow rates through overhead canopies for both cold and hot processes (Stewart, 1985). Appropriate control velocities and convective heat transfer rates are given in Tables 2.36 and 2.37 respectively.

Table 2.38 shows the effects of adjacent surfaces on the basic form of hoods and canopies. However, specific processes may require other hood arrangements not shown in either Table 2.35 or 2.38. A publication by the American Conference of Government Industrial Hygienists (ACGIH, 2013) provides a wide range of empirically based design data sheets for many common industrial processes, which should always be consulted before proceeding with the design of a local exhaust system.

The size, aspect ratio, position and number of openings used depend upon:

- the size and nature of the source (opening must overhang source if possible)
- the dynamics and rate of evolution of contaminant
- the access needs and position of the operator
- the prevailing room air currents (side baffles should be provided if possible).

### 2.6.6.2 Overhead canopies

Overhead canopies are only appropriate for hot processes that cannot be kept covered and must not be used if the operator is likely to lean over the process or if strong cross draughts are likely to occur. Baffle plates can be incorporated into larger hoods to ensure an even velocity across the opening, whilst very large hoods should be sectioned, each section having its own off-take.

### 2.6.6.3 Lateral exhaust

For processes in which the emission momentum is small or tends to carry the pollutant horizontally away from the source, horizontal slots or hoods at the edge of a work surface or tank may be used. Slots may be arranged one above the other (see Figure 2.39) or facing each other along

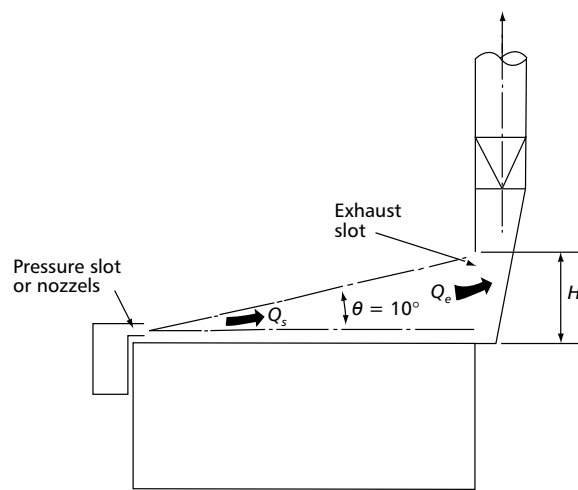
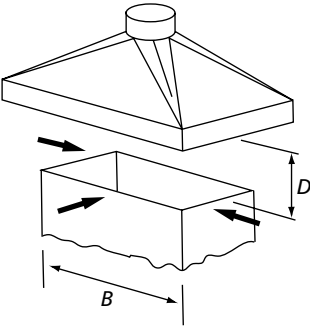
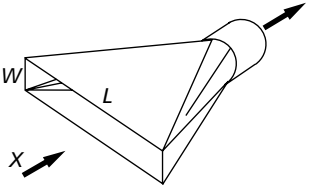
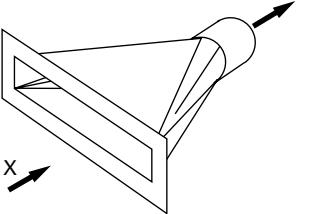
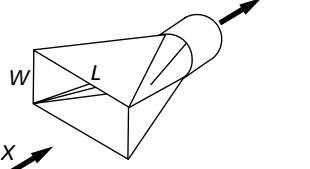
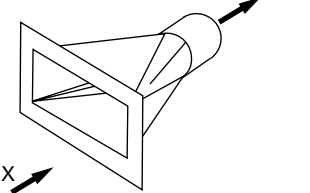

Figure 2.40 Push-pull hood

**Table 2.35** Air volume flow equations for hoods and canopies

Type of opening	Equation	Notes
<p>Canopy</p> 	<p>Cold source:</p> $Q = 1.4 P D v$	<p>If <math>D &gt; 0.3 B</math>, use equation for hot source. Canopy should overhang tank by <math>0.4 D</math> on each side.</p>
	<p>Hot source, exposed horizontal surface:</p> $Q = 0.038 A_s \sqrt[3]{h D} + 0.5 (A - A_s)$	<p><math>Q</math> is progressively underestimated as <math>D</math> increases above 1 m.</p> <p>Canopy should overhang tank by <math>0.4 D</math> on each side</p>
	<p>Hot source, exposed sides and top:</p> $Q = 0.038 A_s \sqrt[3]{(h A_t D) / A_s} + 0.5 (A - A_s)$	<p><math>Q</math> is progressively underestimated as <math>D</math> increases above 1 m. Canopy should overhang tank by <math>0.4 D</math> on each side</p>
<p>Plain slot</p> 	$Q = L v \left( 4 X \sqrt{X/W} + W \right)$	<p>Aspect ratio <math>R</math> should be not less than 10</p>
<p>Flanged slot</p> 	$Q = 0.75 L v \left( 4 X \sqrt{X/W} + W \right)$	<p>Aspect ratio <math>R</math> should be not less than 10.</p> <p>If <math>x &gt; 0.75 W</math>, use equation for plain slot</p>
<p>Plain opening</p> 	$Q = v \left( 10 \sqrt{R} X^2 + A \right)$	<p>Aspect ratio <math>R</math> should not exceed 5; equation may be used for <math>R &gt; 5</math> but with loss of accuracy</p>
<p>Flanged opening</p> 	$Q = 0.75 v \left( 10 \sqrt{R} X^2 + A \right)$	<p>Aspect ratio <math>R</math> should not exceed 5; equation may be used for <math>R &gt; 5</math> but with loss of accuracy</p> <p>If <math>x &gt; 0.75 W</math>, use equation for plain opening</p>

**Symbols:**

$A$  = area of hood/opening ( $m^2$ )

$A_s$  = horizontal surface area of source ( $m^2$ )

$A_t$  = total exposed heated surface area of source ( $m^2$ )

$B$  = breadth of source (m)

$D$  = height above source (m)

$L$  = length of hood/opening (m)

$P$  = perimeter of source (m)

$Q$  = volume flow rate ( $m^3 \cdot s^{-1}$ )

$R$  = aspect ratio ( $L/W$ )

$W$  = width of hood/opening (m)

$X$  = distance from source (m)

$h$  = rate of convective heat transfer ( $W \cdot m^{-2}$ )

$v$  = control velocity ( $m \cdot s^{-1}$ )

opposite long edges, depending upon the vertical distance of the source above the rim of the tank. If the most remote part of the source is less than 0.5 m from the slot, a single exhaust slot along the longer edge is adequate, otherwise two slots, on opposite sides of the source, are required.

#### 2.6.6.4 Jet-assisted hoods

Jet-assisted hoods are non-enclosing hoods combined with compact, linear or radial jets. They are used to separate contaminated zones from relatively clean zones in working spaces. They prevent contaminated air from moving into clean zones by creating positive static pressures, typically in the form of an air curtain.

#### 2.6.6.5 Push-pull hoods

For sources larger than 1 m across, a push-pull hood arrangement should be used (see Figure 2.40) in which a slot or row of nozzles is used to blow air across the source. Design data for the hood illustrated in Figure 2.40 are given below.

Exhaust air quantity:

$$Q_e = (0.5 \text{ to } 0.75) \times A \quad (2.33)$$

where  $Q_e$  is the exhaust airflow rate ( $\text{m}^3\text{-s}^{-1}$ ) and  $A$  is the area of open surface ( $\text{m}^2$ ).

The value of the numerical factor depends on the temperature of the liquid, presence of cross-draughts, agitation of liquid etc.

Supply air quantity:

$$Q_s = \frac{Q_e}{w \times E} \quad (2.34)$$

where  $Q_s$  is the supply airflow rate ( $\text{m}^3\text{-s}^{-1}$ ),  $w$  is the throw length (m) and  $E$  is the entrainment factor (see Table 2.39).

Height of exhaust opening:

$$H = 0.18 w \quad (2.35)$$

where  $H$  is the height (m) of the exhaust opening.

Width of supply opening:

size for a supply velocity of 5–10  $\text{m}\cdot\text{s}^{-1}$ .

The input air volume is usually about 10 per cent of the exhaust volume and the input air should be tempered to avoid frost damage. The source must not be placed in the input air path since this could result in deflection of the contaminant into the workspace. If necessary, baffles or screens should be used to deflect cross draughts.

#### 2.6.6.6 Equipment selection principles and integration

Industrial extract equipment may be selected to:

- conform with emissions standards; industrial processes resulting in polluting emissions to air,

water or land come under the requirements of the Environmental Protection Act 1990 (HMSO, 1990)

- prevent re-entrainment where they may become a health or safety hazard in the workplace
- reclaim usable materials
- permit cleaned air to be re-circulated
- prevent physical damage to adjacent properties
- protect neighbours from contaminants.

Circular ductwork is normally preferred, as it offers a more uniform air velocity to resist the settling of material and can withstand the higher pressures normally found in exhaust systems. Design velocities can be higher than the minimum transport velocity but should never be significantly lower. Fans (or other air-moving devices) and duct materials and construction should be suitable for the temperatures, abrasion and corrosion likely to be encountered. Fans should normally be located downstream of the air cleaner to reduce possible abrasions and create a negative pressure in the air cleaner so leakage will be inward. However, in some instances the fan may be located upstream from the cleaner to help remove dust.

Exhaust stacks must be designed and located to prevent the re-entrainment of discharged air into supply system inlets (see section 2.6.5). Toxic and hazardous exhaust must not be discharged in a manner that will result in environmental pollution and the local authority environmental health officer should be consulted to ensure that the proposed discharges will be acceptable.

### 2.6.7 Duct equipment

#### 2.6.7.1 General

Ducting is generally available in rectangular, circular and flat oval sections, although other sections may be made for special situations. The majority of rectangular ductwork is made to order and available in any reasonable dimensions. Ductwork with less than 0.0225  $\text{m}^2$  cross-sectional area (e.g. 150 mm  $\times$  150 mm) will generally be more economic if made from circular section.

The designer should consider the full range of sections available and combine them to suit the specific location. Recommended sizes for rectangular, circular and flat oval ductwork are given in Appendix 2.A1.

#### 2.6.7.2 Types of duct

##### *Rectangular ducting*

Rectangular ducting is most common for low-pressure systems because:

- it is readily adapted to fit into the space available
- it can be readily joined to such component items as heating and cooling coils and filters
- branch connections are made more easily.

For overall economy and performance, the aspect ratio should be close to 1:1 since high aspect ratios increase the pressure loss, the heat gains/losses and the overall costs.

**Table 2.36** Control velocities for hoods

Condition	Example	Control velocity / m·s <sup>-1</sup>
Released with practically no velocity into quiet air	Evaporation from tanks, degreasing etc.	0.25–0.5
Released at low velocity into moderately still air	Spray booths, intermittent container filling, low speed conveyor transfers, welding, plating	0.5–1.0
Active generation into zone of rapid air motion	Spray painting in shallow booths, conveyor loading	1.0–2.5
Released at high initial velocity into zone of very rapid air motion	Grinding, abrasive blasting	2.5–10

Note: the higher values apply if (a) small hoods handling low volumes are used, (b) hoods are subject to draughts, (c) the airborne contaminant is hazardous, or (d) hoods are in frequent use.

**Table 2.37** Convective heat transfer rates for horizontal surfaces

Surface temperature / °C	Rate of heat transfer / W·m <sup>-2</sup>
100	580
200	1700
300	3060
400	4600
500	6600

**Table 2.38** Effect of side walls and adjacent surfaces

Type of opening	Baffle	Effect
Canopy, cold source	Side walls	Reduces effective perimeter, hence flow rate Q is reduced
Canopy, hot source	Side walls	Reduces cross draughts but minimal effect on flow rate Q
Plain slot	Long side on flat surface	$Q = L v \left( X \sqrt{2X/W} + W \right)$
Plain opening	Long surface on flat surface	For $R \leq 2$ : $Q = v \left( 5 \sqrt{(2/R)} X^2 + A \right)$
		For $2 < R \leq 5$ : $Q = v \left( 5 \sqrt{(R/2)} X^2 + A \right)$
Flanged slot or opening	Long side (not flanged) on flat surface	For $X > 0.75$ , calculate flow rate Q for plain arrangement and multiply by 0.75 W

Symbols:

A = area of hood/opening (m <sup>2</sup> )	v = control velocity (m·s <sup>-1</sup> )
L = length of hood/opening (m)	W = width of hood/opening (m)
Q = volume flow rate (m <sup>3</sup> ·s <sup>-1</sup> )	X = distance from source (m)
R = aspect ratio (= L/W)	

However, ducts with a 1:1 aspect ratio require a deep service area and are therefore rarely used in ceiling zones due to space limitations.

Rectangular ducting should not be the first choice for high-pressure systems, as it requires strengthening of the flat sides and needs to be sealed to make it suitable for this application.

### Circular ducting

Machine-formed, spirally wound ducting and a standard range of pressed and fabricated fittings makes circular ducting more economical, particularly in low-pressure systems having a relatively small proportion of fittings. It is likely to be easier to install, particularly for the main runs of ductwork.

**Table 2.39** Entrainment factors for push-pull hoods

Throw length / m	Entrainment factor
0–2.5	6.6
2.5–5.0	4.6
5.0–7.5	3.3
>7.5	2.3

Circular ducting is preferable for high-pressure systems and for systems operating at high negative pressures, due to its high inherent stiffness. Additional stiffening rings may be necessary at high negative pressure.

Pressed and fabricated fittings can be made of metal or plastic and fitted with push fit gasketed connectors for simple fitting and good airtightness.

### Flat oval ducting

Flat oval ducting provides an alternative to circular ducting principally where there is a limitation on one of the dimensions in the space available for the duct run (e.g. depth of ceiling space). It combines the advantages of circular and rectangular ductwork because it can fit in spaces where there is insufficient room for circular ducting and can be joined using the techniques for circular duct assembly. Flat oval ducting has considerably less flat surface that is susceptible to vibration and requires less reinforcement than the corresponding size of rectangular duct. Flat oval duct is suitable for both positive and negative pressure applications within the limits defined in DW/144: *Specification for Sheet Metal Ductwork* (BESA, 2013a).

### Other sections

Other sections may be used, such as triangular sections to pass through roof trusses. Such sections present difficulties in the provision of fittings and connections to standard plant items and are likely to be more expensive than traditional sections.

## 2.6.7.3 Bend and duct fitting components

### Background

In normal circumstances, the flow of air in ducts is turbulent, with the flow generally in the direction of the duct axis. Eddies and secondary motions will result in energy dissipation due to internal fluid friction. Streamlines will not be parallel to the duct centre-line. In unobstructed straight ducts, eddies give rise to only relatively small

transverse components of the duct velocity and the flow velocities are symmetrical about the duct axis.

Disturbance to the flow arising from obstructions, duct fittings or other components has two major effects.

- The eddies can be significantly larger in size and their velocities much higher.
- The flow velocities across the duct become asymmetrical, i.e. much higher velocities can occur in part of the duct section, whilst in other parts even reverse flow may occur.

From the point of view of duct design, the important aspects of the effects of disturbance to airflow are:

- increased pressure loss due to creation of eddies
- increased pressure loss as high-velocity air mixes with low-velocity air
- noise generated by the interaction on eddies with the inner surfaces of the ducts.

### Bends

Figure 2.41 illustrates common bend types; their influence on the airflow is described below. Bends may be characterised as ‘hard’ or ‘soft’ according to whether the change of direction is in the plane of the longer or shorter side of the cross section, respectively (see Figure 2.42).

#### Radiused bends

The air will flow to the outer surface causing high velocities at discharge on the outside with much lower velocities on the inside. In addition, the centrifugal effect will cause a higher static pressure at the outer surface, leading to some transverse flow towards the inner surface, and hence producing a spiral motion at the outlet. If the bend is too tight (i.e.  $r/w < 1$ ), flow will readily separate from the inside surface with subsequent eddying and increased pressure loss. In practice, radiused bends should have an  $r/w$  value of 1.5; for low pressure-loss situations  $r/w$  should be increased to 2. They should have a downstream straight duct of at least five equivalent diameters to allow the flow to stabilise again. As a general rule, the formation of an offset in a duct layout is better achieved using two angled bends ( $< 90^\circ$ ) rather than two right-angled bends.

(Note: in this Guide,  $r$  is taken as the mean radius of the bend to the centre-line of the duct; DW/144: *Specification for Sheet Metal Ductwork* (BESA, 2013a) relates  $r$  to the throat radius of the duct.)

#### Splitter bends

These are tight radiused bends that use internal splitters to improve the airflow (see Figure 2.43). Standard settings for splitters are given in Table 2.40, which is taken from BESA (2013a). The flow in the air passages is as described for the radiused bend, but because multiple streams emerge at discharge, the outlet velocity profile will be more uniform than for a plain radiused bend. Hence the minimum straight length of downstream duct may be reduced to about four equivalent lengths.

#### Mitred elbows (with turning vanes)

Rectangular duct bends with either dimension greater than 200 mm should have properly designed turning vanes. The angle of the turning vane should be the same as that of the bend. Information on the structural requirements of turning vanes is given in DW/144: *Specification for Sheet Metal Ductwork* (BESA, 2013a). The advantage of this type of bend is that it should not significantly distort the velocity profile, so that other duct fittings or components can be placed closer to the outlet, provided the inlet conditions to the bend are uniform. If the flow is not uniform at the inlet, this non-uniformity may persist downstream of the bend.

Optimum design of turning vanes, with careful positioning, should provide a bend with less resistance to airflow than a good design of radiused bend, but this may not be achieved in practice. This is because the inside and outside corners of the bend are usually not rounded, and internal and side fixings provide some obstructions. The pressure losses may then be a little higher than those in a good design of radiused bend, particularly in the case of small duct sizes. Eddies will be formed where air separates from the outside surface of a turning vane causing this type of bend to generate more noise than radiused and splitter bends.

Research by the American Sheet Metal and Air Conditioning Contractors' Association (SMACNA, 2006) on a 600 mm square elbow with blades of 114 mm radius shows the optimum spacing to be 82 mm. When the length of the blades is greater than 900 mm, it is preferable to use double thickness turning vanes to add stiffness, but there is a penalty due to increased pressure drop.

#### Mitred elbows (without vanes or splitters)

This type of bend is not recommended for bends with angles  $> 30^\circ$  because the flow becomes both distorted and very turbulent. The flow leaves the bend with higher velocities on the outside surface, and separation occurs at the inside sharp edge, leading to severe eddying. The one advantage of this eddying is that it will lead to mixing of temperature-stratified air but the pressure loss will be high, with large pressure losses resulting (see section 4.11.2.4 of CIBSE Guide C (2007)). For low-velocity systems, mitred elbows can produce useful sound attenuation due to a reflection effect. Other fittings should not be placed close to the elbow.

#### Branches

There are many designs of branches and junctions in use. The important features are that the flow should be divided (or combined) with the minimum interference and disturbance, and that changes in duct sizes should not be made at the branch but at a short distance downstream (or upstream).

Examples of good and economic branch design are shown in Figure 2.44. A good branch design cannot be effective if the flow entering the branch is not uniform across the section. For some of the BESA recommended tee designs, no experimental data are available for the pressure loss, but the designer should consider their use. Chapter 4 of CIBSE Guide C (2007) provides useful information. Note that the addition of a small shoe on the branch tee can reduce pressure loss in both the branch flow and the straight flow.

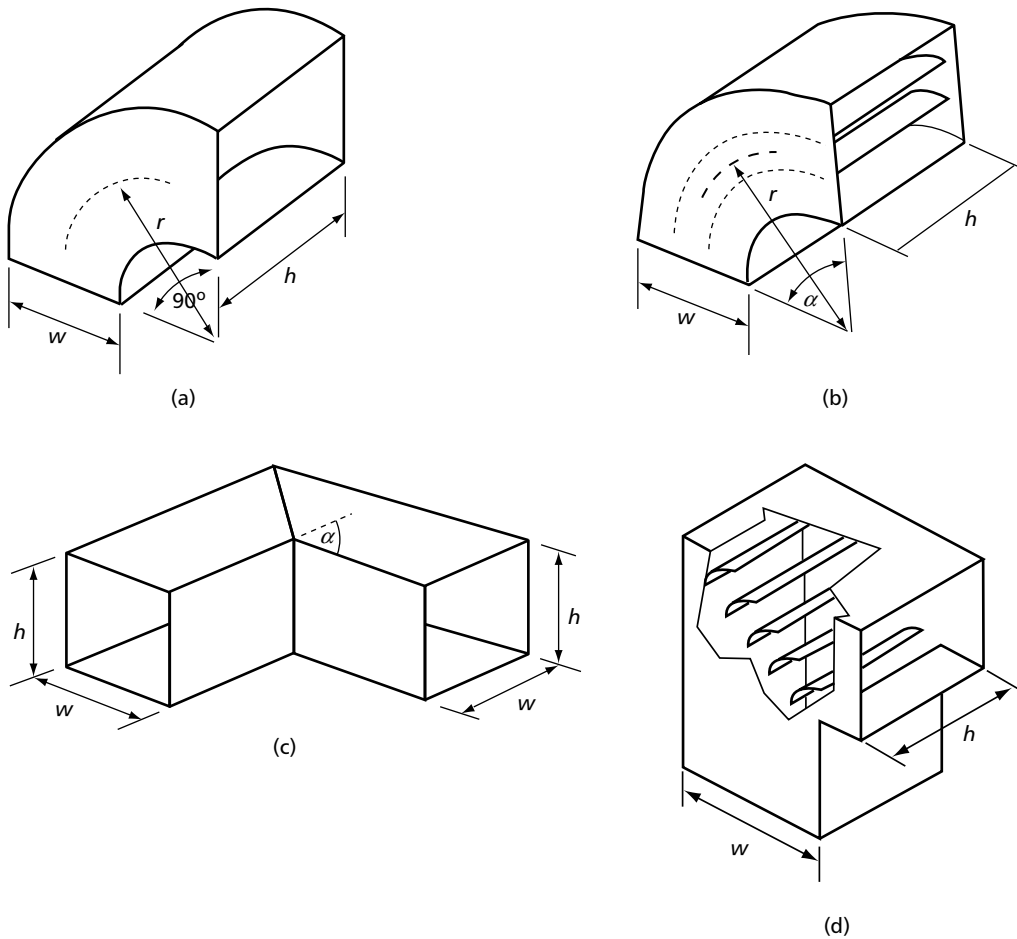

**Figure 2.41** Common types of bends: (a) 90° radius bend without vanes, rectangular, (b) short radius bend with vanes (any angle), rectangular, (c) mitred elbow without vanes (any angle), (d) 90° mitred elbow with vanes

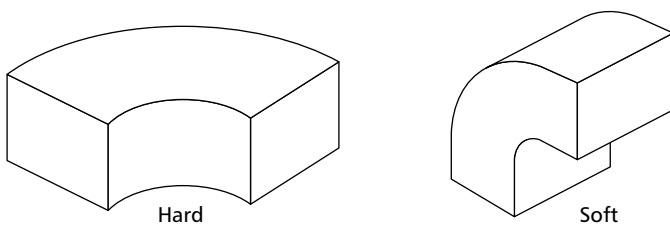

**Figure 2.42** 'Hard' and 'soft' bends

DW/144: *Specification for Sheet Metal Ductwork* (BESA, 2013a) suggests appropriate shoe dimensions for various sizes of duct.

**Change of section**

**Expansion**

A tapered expansion of a duct causes an appreciable pressure loss due to the tendency of the flow to break away from the sides and form eddies. The greater the total included angle of divergence, the greater the pressure loss, especially for large changes in area.

The cheapest form of taper for rectangular ductwork is to maintain the same plane for three sides and incline the fourth side only (see Figure 2.45). In any diverging section, when the plane of any side changes by more than 22.5°, DW/144: *Specification for Sheet Metal Ductwork* (BESA, 2013a) recommends the inclusion of splitter vanes, which should bisect the angle between any side and the duct centre-line (see Figure 2.46). However, it is not clear by how much the friction pressure drop is reduced by the

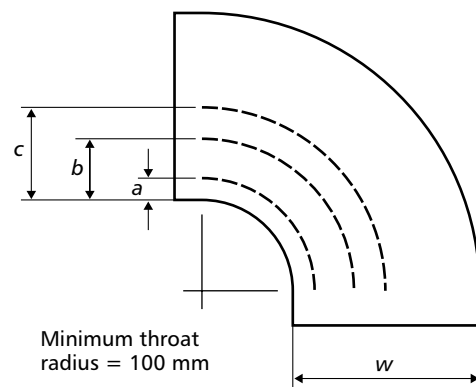

**Figure 2.43** Short radius bend with splitters; position of splitters (reproduced from DW/144: *Specification for Sheet Metal Ductwork* (BESA, 2013a) by permission of BESA)

**Table 2.40** Short radius bends with splitters; position of splitters (BESA, 2013a)

Dimension $w$ / mm	Number of splitters	Splitter position		
		A	B	C
400–800	1	$w/3$	—	—
800–1600	2	$w/4$	$w/2$	—
1600–2000	3	$w/8$	$w/3$	$w/2$

Note: splitters not required for bend angles less than 45°

introduction of such vanes. Certainly the inclusion of splitters would not seem worthwhile when the change in section  $(A_2/A_1) > 4$ . Further information can be found in CIBSE Guide C, chapter 4 (2001).

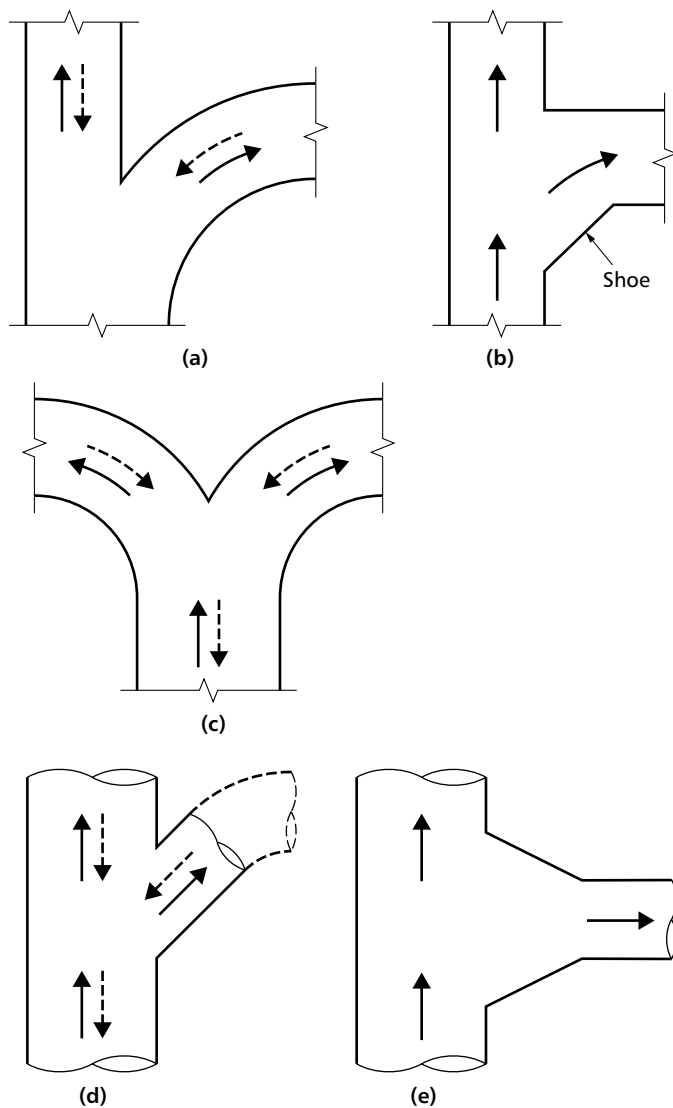

**Figure 2.44** Examples of good duct design; (a) 90° swept branch, rectangular, (b) 90° branch tee with shoe, rectangular, (c) 90° radiused twin bend, rectangular, (d) 45° branch tee, circular, (e) 90° conical branch tee, circular

### Contraction

Relatively little pressure drop is caused by a contraction. The designer should not feel constrained in choosing the taper angle for a contraction. No splitter vanes are needed for a contraction.

### Other fittings

As a general rule, fittings should avoid abrupt changes in direction and sharp edges that cause the flow to separate and form eddies, which in turn increase pressure loss and noise generation. A fitting such as a damper can create vortices, which will result in a greater pressure drop than normal in a subsequent downstream fitting. Separation between the fittings by a minimum length of 5 equivalent diameters is recommended.

In the case of bends in rectangular ductwork, the combination of two bends in close proximity can give a lower pressure drop than two that are far apart. Further information can be found in CIBSE Guide C, chapter 4 (2007). This is not the case for two segmented circular ducts in close proximity, but the effect of close coupling is not significant.

## 2.6.7.4 Duct support and fixing components

### General

Supports are an essential part of the ductwork system and their supply and installation are normally the responsibility of the ductwork contractor. The choice between available methods of fixing will depend on the type of building structure and on any limitations imposed by the structural design. Unless the designer has specified the requirements in detail, the load to be carried will be understood to be limited to the ductwork and its associated thermal and/or acoustic insulation. However, where the duct is large enough to allow human access for cleaning, the duct and its supports should be sufficiently strong to withstand the additional load and the type and location of access components should allow the person carrying out the cleaning to enter and exit the duct. The range of supports available includes an increasing range of proprietary types.

With a proprietary device, unless the designer has specified the requirements in detail, it will be the responsibility of the ductwork installer to ensure that it meets the requirements, with a sufficient margin of overload, and that it is installed in accordance with the manufacturers' recommendations.

### Fixing to building structure

The fixing to the building structure should be of a strength and durability compatible with those of the ductwork support attached to it. A fixing to concrete or brickwork must be made in such a way that it cannot loosen or pull out through normal stressing or through normal changes in the building structure.

### Horizontal ductwork

The hanger is normally mild steel plain rod or studding or flat strap, pre-treated by hot-dip galvanising, sherardising, electro-deposited zinc plating or other acceptable anticorrosion treatment. Other materials, such as multi-stranded wire, may also be acceptable. Provided the integrity of the ductwork is maintained, hangers may be attached to the corners of either the flanges or stiffeners, as an alternative to the use of a bottom bearer. Details of the construction of supports are given in DW/144: *Specification for Sheet Metal Ductwork* (BESA, 2013a).

Where horizontal ductwork passes through a compartment boundary such as a wall, fire dampers should be used to maintain fire integrity

### Vertical ducts

The design of supports for vertical ducts is dictated by site conditions and they are often located to coincide with the individual floor slabs. The designer must specify the particular requirements if the spacing exceeds four m. Vertical ducts should be supported from the stiffening angle or the angle frame or by separate supporting angles fixed to the duct.

Where vertical ductwork passes through a compartment boundary such as a floor, fire dampers should be used to maintain fire integrity.

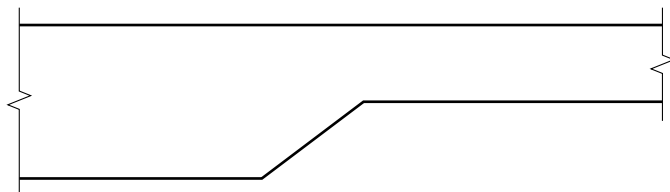

Figure 2.45 Change of section for a rectangular duct; one side only inclined

The support bearer, which, depending on duct/structural opening size, could be either channel or angle section, may be utilised in any of the following arrangements:

- Fixed directly to duct skin with sealed fixings (flat face only of either rectangular or flat oval ductwork).
- Supporting the underside of a flat bar clip in halves (circular or flat oval ductwork).
- Supporting the underside of either the stiffening frame or the flanged joint of any duct section.
- Supporting either a stiffening frame or a flanged joint below using drop rods/studs.

*Insulated ducts with vapour sealing*

Vapour sealing may be required where the temperature of the air within the duct can fall low enough to promote condensation on the exterior surface of the duct. This can cause moisture penetration through the thermal insulation.

In this case, the most important requirement is to limit penetration of the seal by the support. The extent of any vapour sealing of ductwork thermal insulation, and the method to be used, must be clearly specified in advance by the designer.

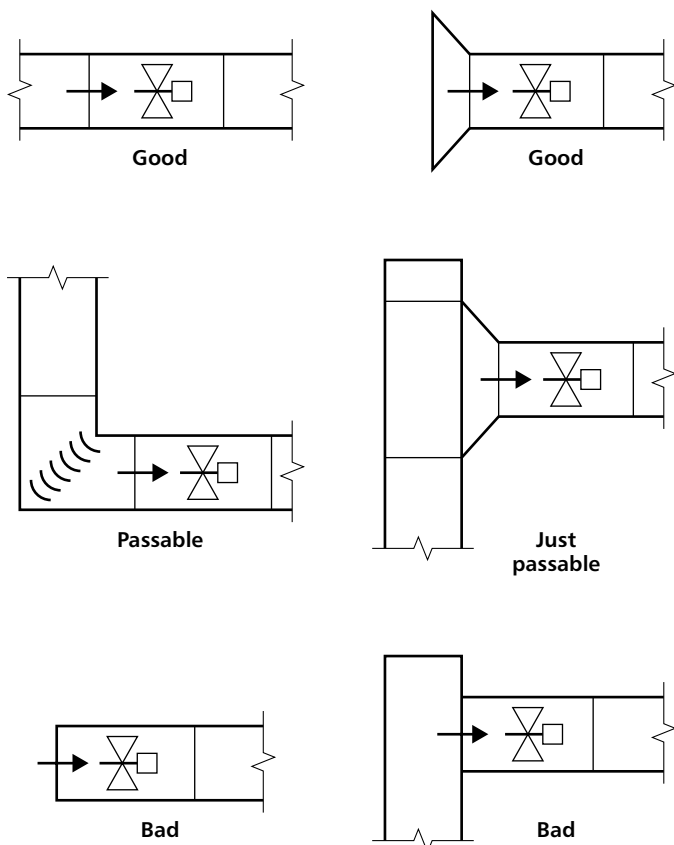

Figure 2.47 Outlet connections to centrifugal fans

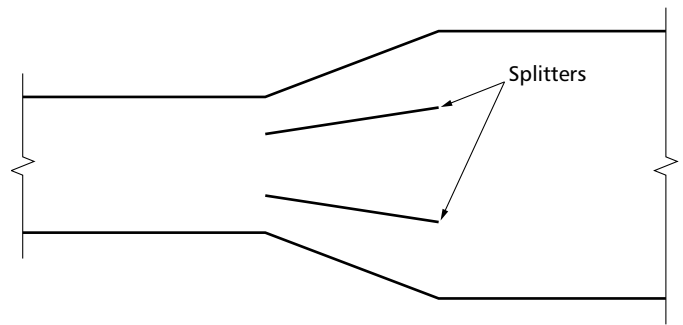

Figure 2.46 Change of section for a rectangular duct with splitters

*Heat transfer*

It is not normally necessary to make special arrangements for the limitation of heat transfer via the duct supports. However, there may be special cases where the temperature difference justifies a heat barrier to conserve heat or to prevent condensation. Such requirements must be specified by the designer.

*Fire-resisting ductwork*

Ductwork supports illustrated in DW/144: *Specification for Sheet Metal Ductwork* (BESA, 2013a) cannot be used on fire-rated ductwork systems. Oversizing can be an acceptable method of achieving fire rating of supports.

Fire-resisting ductwork may be required to meet the requirements of either European or British standards. Further comprehensive information may be found in the *Fire Rated and Smoke Outlet Ductwork* ('the ASFP Blue Book') (ASFP, 2000). Additional information may also be found there for smoke control ductwork.

**2.6.8 Ductwork connections**

**2.6.8.1 Fan connections**

The fan performance figures given by manufacturers in their catalogue data are based on tests carried out under ideal conditions, which include long uniform ducts on the fan inlet/outlet. These standard test conditions are unlikely to occur in practice. An objective of good ductwork design should therefore be to ensure that, as far as practicable, the fan performance will not be de-rated by the system. Ensuring that the fan inlet flow conditions comprise uniform axial flow velocities with low levels of turbulence can help to achieve this.

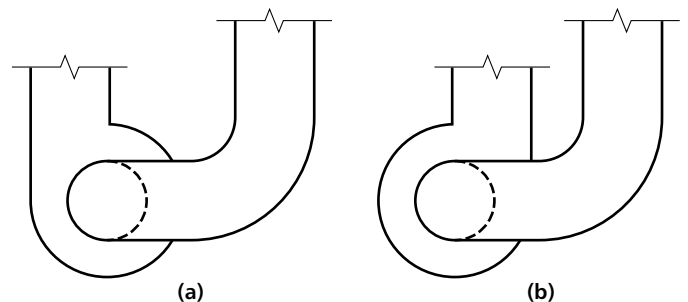

Figure 2.48 Centrifugal fan, swirl to impeller rotation: (a) swirl in same direction as impeller, (b) swirl in contrary direction to impeller

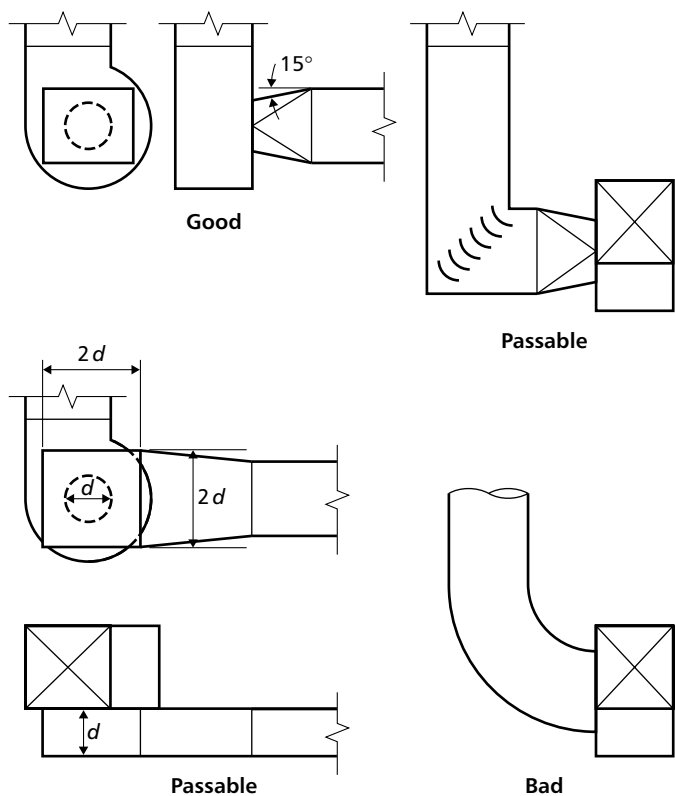

Figure 2.49 Centrifugal fans; inlet connections

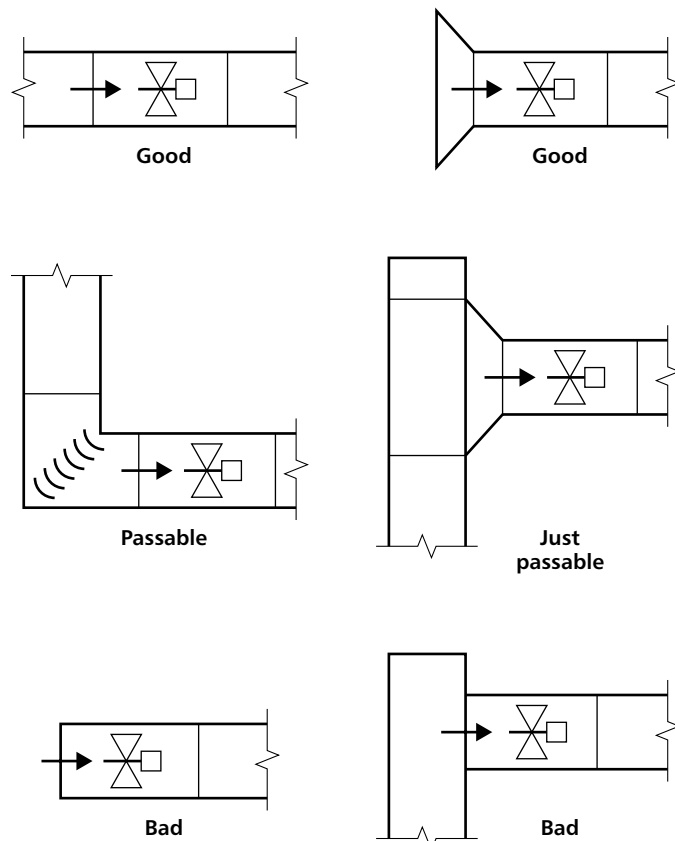

Figure 2.50 Axial fans; inlet connections

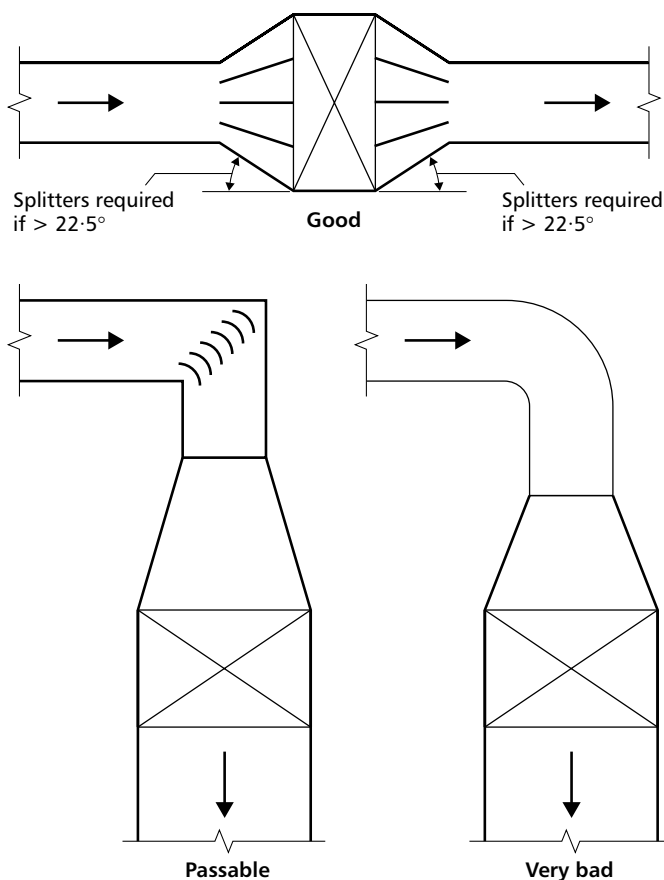

Figure 2.51 Plant connections

Where the outlet duct is larger than the fan discharge connections, there should be a gradual transition as illustrated in Figure 2.47 with a following section of straight duct having a length equivalent to three duct diameters. Figure 2.48 also gives examples of good and bad centrifugal fan outlet connections, which apply equally to axial flow fans.

The design of the fan inlet connection must be carefully considered to avoid swirl in the airstream. When the air spins in the same direction as the impeller, the performance and power consumption of the fan are reduced. When the air spins in the opposite direction to the impeller, the power consumption and noise will increase with hardly any pressure increase. Airstream swirl is usually induced by large variations across the fan inlet eye caused by the air passing round a tight bend immediately before the eye. The two forms of connection to centrifugal fans likely to cause swirl are shown in Figure 2.47.

For any condition in which a centrifugal fan is located within a free inlet the clear distance between the suction opening and the nearest wall should not be less than the diameter of the inlet. If two fans with free inlets are positioned within the same chamber their adjacent suction openings should be at least 1.5 diameters apart. Examples of good and bad practice in duct inlet connections to centrifugal fans are shown in Figure 2.48 and to axial fans in Figure 2.50.

2.6.8.2 Plant connections

Airflow across air treatment components such as filters, heat exchangers and humidifiers will be influenced by the pattern of the approaching airstream and, if unsatisfactory conditions are created, the performance of the components

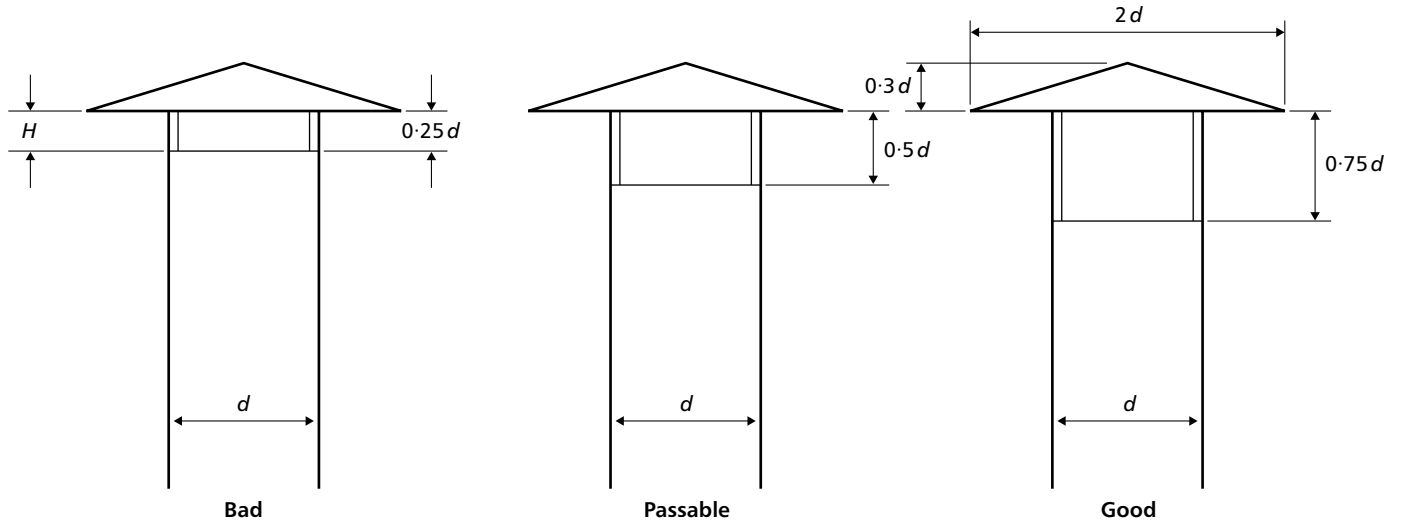

Figure 2.52 Discharge cowls; good and bad design

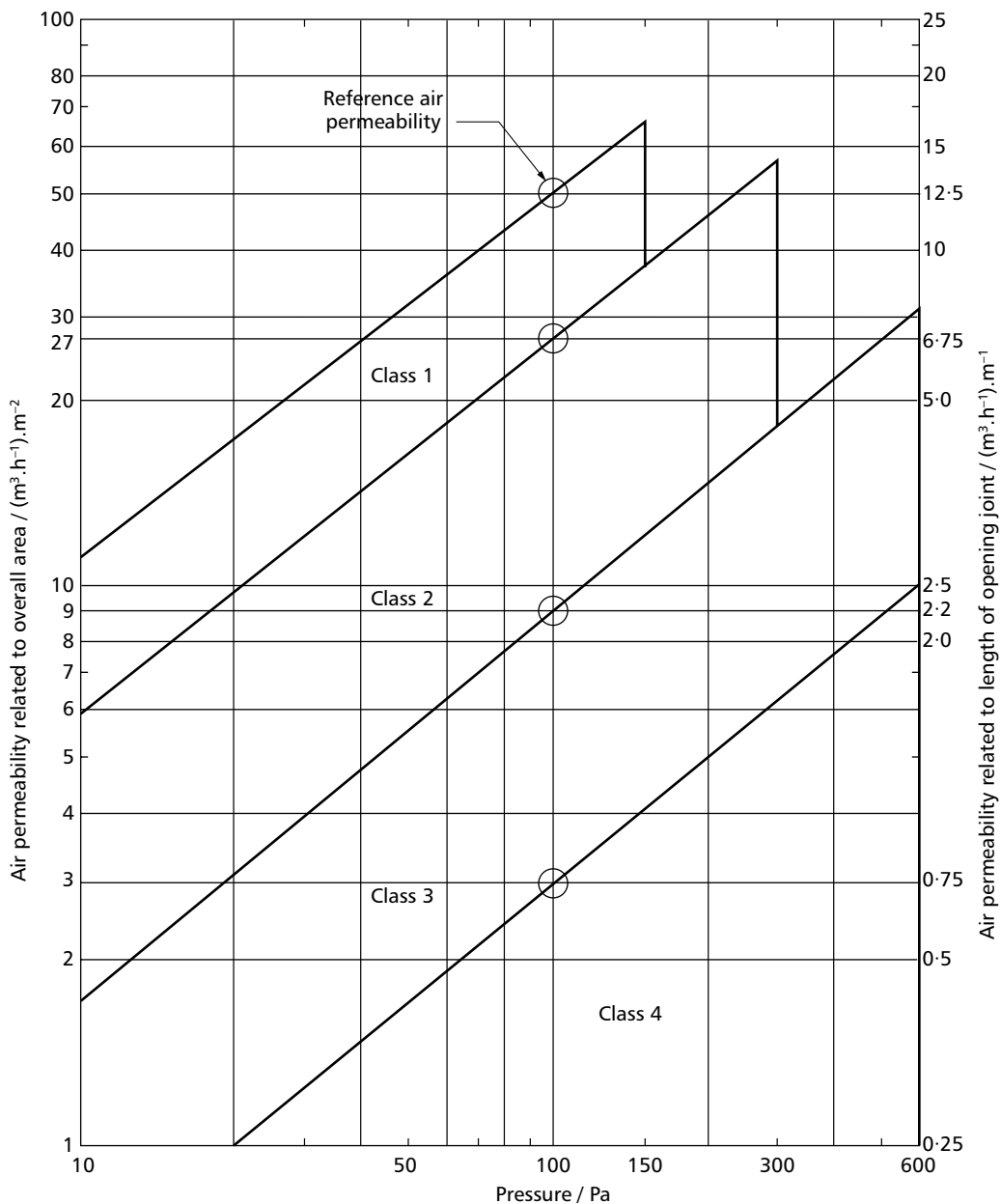

Figure 2.53 Classification of doors and windows by air permeability (reproduced from BS EN 12207: 2000: *Windows and Doors. Air permeability. Classification* (BSI, 2000) by permission of the British Standards Institution)

This publication is supplied by CIBSE for the sole use of the person making the download. The content remains the copyright of CIBSE.

will be reduced. Examples of good and bad practice are shown in Figures 2.51 and 2.52 below.

### 2.6.8.3 External louvres and cowl connections

Recommendations on the clearance that should be provided between a cowl and an external vertical duct opening are illustrated in Figure 2.52 (see also sections 4.11.2.31–4.11.2.35 of CIBSE Guide C (2007)). Where adequate clearance cannot be provided, fitting an inverted cone deflector under the cowl can reduce the resistance.

## 2.6.9 Natural ventilation equipment

### 2.6.9.1 Openable window design

BS EN 12207: 2000: *Windows and doors. Air permeability. Classification* (BSI, 2000) classifies window and door performance according to their permeability (see Table 2.41 below). Reference air permeabilities are recorded for each class of window related to the permeability of both the overall area and of the opening joint. These are defined at a test pressure of 100 Pa. BS EN 12207: 2000 (BSI, 2000) describes how limits can be defined for other test pressures and how windows are subsequently classified according to the relationship between the two permeability assessments.

Figure 2.53 shows the upper limits of each class, which are derived from the reference air permeabilities at 100 Pa related to the area and length of opening joint, see Table 2.41.

General information on window design and selection is available from other CIBSE/SLL publications such as SLL LG10: *Daylighting — A guide for designers* (SLL, 2015) and CIBSE AM10: *Natural ventilation in non-domestic buildings* (2005). There are a number of important criteria, which are outlined in the following sections.

#### Ventilation capacity

The ventilation capacity is the amount of air that will flow through a given window area of different designs. It depends on the ratio of the effective open area to the façade area of the window unit. Ventilation capacity will be maximised by increasing the vertical separation and magnitude of those open areas. This will in turn depend on the way the window opens (i.e. side, top/bottom, centre pivot, sliding etc.), and the distribution of the open area over the vertical height of the window. Figure 2.54 shows the open areas for a horizontal centre pivot window compared with a side-hung window. A typical pressure gradient caused by inside–outside temperature differences is also shown. The centre pivot window has a much higher ventilation capacity because the open area is concentrated at regions of high pressure difference. In contrast, much of the open area of side-hung windows is in a region of small pressure difference.

#### Adjustability

Good control at small openings is particularly important for winter comfort. The flow characteristic is influenced by the mode of opening the window and factors such as the

**Table 2.41** Reference air permeabilities at 100 Pa and maximum test pressures related to overall area and length of opening joint

Class	Reference air permeability at 100 Pa and maximum test pressure			
	Related to overall area		Related to length of opening joint	
	Permeability / (m <sup>3</sup> ·h <sup>-1</sup> )·m <sup>-2</sup>	Max. test pressure / Pa	Permeability / (m <sup>3</sup> ·h <sup>-1</sup> )·m <sup>-1</sup>	Maximum test pressure / Pa
0*	—	—	—	—
1	50	150	12.50	150
2	27	300	6.75	300
3	9	600	2.25	600
4	3	600	0.75	600

\* Not tested

shape and thickness of the window frame. Figure 2.55 illustrates that the effective open area of a window may not increase very rapidly until the opening angle is quite large.

#### Impact on comfort

The position of the room air inlet will have an effect on comfort factors such as draughts. Air entering the space at the occupied level can improve comfort in summer, when the air movement will provide a cooling benefit. In winter when the entering air is much colder, the same opening may result in discomfort from draughts. Consequently, separate winter openings may be preferred (either separate high-level windows or trickle ventilators). To avoid high summer ventilation rates (causing papers to be disturbed), the height of that part of the window where air enters the space should be above desk level.

#### Thermal contact

In strategies utilising night cooling and thermal capacity, the ventilation air needs to be able to make good thermal contact with the fabric in order to effect good heat transfer.

#### Security

The implications of open windows, particularly in night ventilation mode, need to be considered. Some window designs can be lockable in a part-open position, which allows adequate night ventilation rates but minimises the risk of intruders gaining access to the building.

#### Integration with solar control strategies (particularly blinds)

The blind and window opening may interact in a number of ways including:

- the movement of the window may be restricted by an independent internal (or external) blind; this is mainly a problem for pivoting windows
- with pivoting windows and mid-pane blinds, there is the impact on shading performance when the angle of the blind louvres to the incident radiation changes as the window is opened
- the effect of the blind in providing a resistance to airflow; the blind elements (unless they are mid-pane) will provide an obstruction to the free area of

the opening (this is independent of window type, see Pitts and Georgiadis (1994)).

*Window specification*

Information on the performance characteristics of various window types (see Figure 2.56) is given below. The effect of these different characteristics should be assessed with reference to the criteria listed above.

- *Horizontal pivot windows:* these have a high ventilation capacity because large open areas are created at a separation equivalent to the window height. With single-sided ventilation, air will enter at the lower level and exit via the top of the window. An opening of 22° is usually considered the norm for ‘fully open’; for example for a typical 1200 mm wide by 1600 mm high window this results in an effective open area of 0.66 m<sup>2</sup>. They are easily adjustable to provide control of the ventilation rate. Maximising the height of the top of the window in the room will help exhaust warmer air at ceiling level when operating in single-sided ventilation mode. Glazing at high level will also promote good levels of natural light deep into the space. When operating in wind-driven cross-ventilation mode, air will enter at the top and bottom of the window. The air entering through the top gap will be directed upward and this can improve thermal contact with exposed ceilings for effective night ventilation. Solar radiation striking the opaque surfaces of the wall or the ground adjacent to the façade can generate rising convection currents. These can be deflected into the room if the outward projection of the window extends beyond the window reveal.
- *Vertical pivot windows:* because the opening is distributed uniformly over their height, these windows have a lower ventilation capacity. For the same 22° opening, the effective open area is reduced by 40 per cent relative to the horizontal pivot. Vertical pivot windows can act as a form of ‘wind scoop’ for wind directions parallel to the face of the building. Because they have a large vertical opening, they are more likely to allow rain into the building. Carefully designed weather stripping is required for both horizontal and vertical centre pivot windows to achieve a good performance in winter.
- *Top/bottom hung windows:* as ventilators, these are less effective still, since all the opening area is concentrated at one end of the window height. The effective open area is about 35 per cent of the horizontal pivot type. Depending on where the

opening is, the summer ventilation will either provide cooling to the occupant and poor thermal contact with the ceiling, or vice versa. Top hung windows can act as scoops for warm air rising up the outside of the building (e.g. from convection currents generated by solar gain on building surfaces).

- *Side-hung windows:* these are similar in performance terms to vertical pivot windows. Because of the greater distance from window edge to pivot (and hence greater turning moment), they are more susceptible to being blown by gusts of wind. Inward opening windows can cause clashes with furniture positions. The combination of top-hung winter ventilators and side-hung summer windows (with effective weather stripping) provides good all-round performance. The top hung winter ventilator can also provide a secure opening for summer ventilation that, in combination with the side-hung opening, will enhance stack effect.
- *Sliding windows (including sash):* depending on whether they are vertical sliding (sash) or horizontal sliding windows, these will have similar ventilation characteristics to the horizontal and vertical pivot window respectively. Sliding windows can provide good control over summer ventilation. Sash windows allow the stack effect to be controlled through adjustment of the opening size at both the top and bottom of the window. However, ensuring a good seal in the closed position requires particular attention. This is important in terms of reducing draughts and energy losses in winter. Recent designs have significantly improved the performance of sliding windows in this respect. The design of sash windows needs to be such as to facilitate easy opening of the upper sash.
- *Tilting top vents:* these provide smaller opening areas than the other systems, because the opening portion

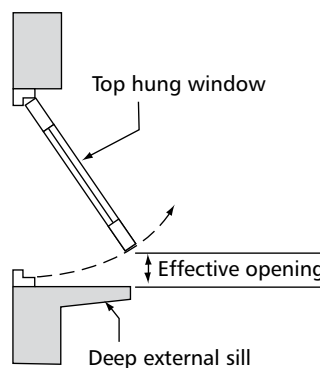

Figure 2.55 Effect of a sill on the relative open area of a window

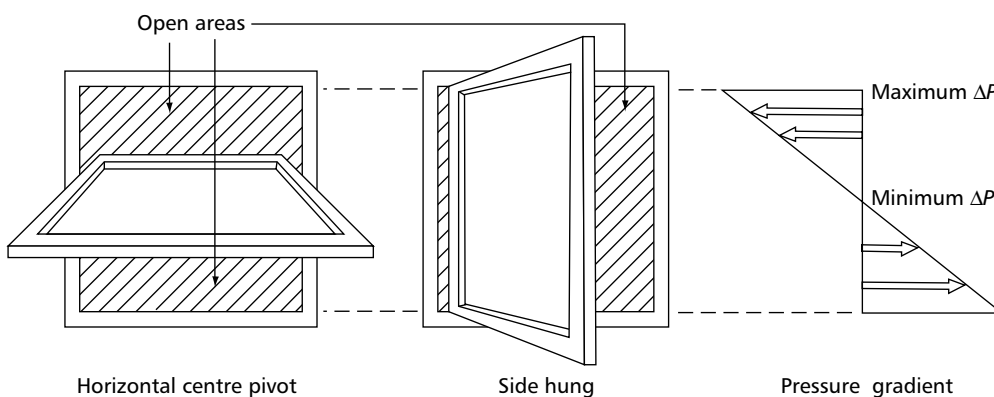

Figure 2.54 Ventilation capacity of different window configurations

occupies only a proportion of the window height. However they can provide good draught-free ventilation, especially in cross-ventilation mode. If the vent is bottom hung and opening inwards (the 'hopper' window), the natural flow pattern may encourage good thermal contact with the ceiling. However, care must be taken to protect the opening from driving rain.

- *Tilt and turn windows*: these are a combination unit offering bottom- and side-hung options (although the side-hung mode is mainly intended for cleaning purposes). A study of several buildings by Willis *et al.* (1995) suggests that the tilt setting provides too much ventilation in winter and insufficient ventilation in summer. The turn mode can cause clashes with furniture.

Whereas windows perform many functions, sections 2.6.9.2 to 2.6.9.8 describe openings in the façade whose sole purpose is to provide ventilation. Note that any such devices should offer a very low resistance to airflow, as the driving forces for natural ventilation may only be in the region of 10 Pa. Further guidance on product development and natural ventilation design tools is available from BRE (1999c).

### 2.6.9.2 Air bricks and trickle ventilators

Air bricks incorporate no provision for control of infiltration rate. Automatic ventilators, which provide nominally constant infiltration under variable wind velocities, should be considered as an alternative. The concept of 'build tight, ventilate right' is increasingly recognised as the basis of good design for ventilation. This relies upon an airtight fabric and the provision of a means of controlled background ventilation. In a naturally ventilated building this is often provided by trickle ventilators with higher rates of ventilation provided by other means such as the window or specific controlled damper devices.

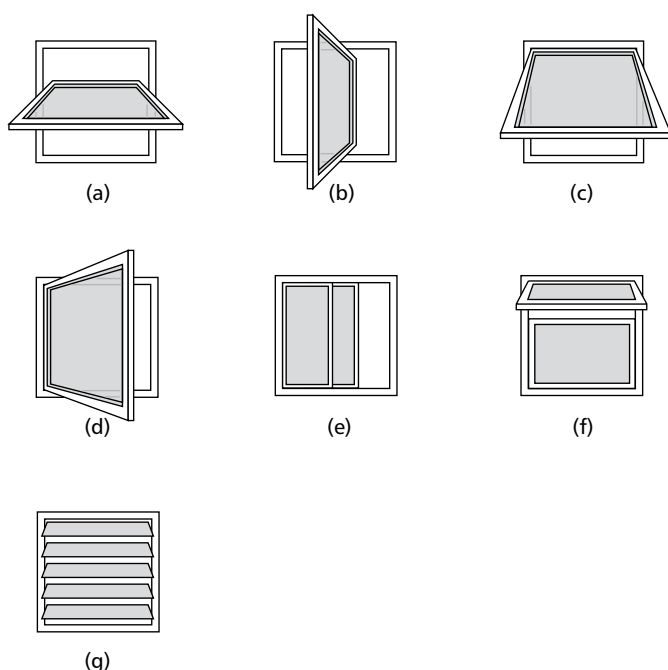

**Figure 2.56** Window types: (a) horizontal pivot, (b) vertical pivot, (c) top/bottom hung, (d) side hung, (e) sliding, (f) tilting top vent, (g) louvre

Trickle ventilators are usually designed to provide the required minimum fresh air rate, particularly in winter. For England and Wales, Part F of the Building Regulations (NBS, 2010b) should be consulted for further details of the requirements, and the *Technical Handbook* (Scottish Government, 2015) for requirements in Scotland.

Draughts, especially those occurring at ankle height, can be avoided by directing the incoming air upwards, or positioning the ventilators at high level, e.g. > 1.75 m above the floor. This allows incoming air to mix with the warmer room air before reaching floor level. Alternatively, air can enter through wall ventilators positioned behind heaters. The form of the ventilator should promote rapid mixing with the room air to minimise cold draughts. General guidance on the use of trickle ventilators has been published by BRE (1998).

Added to this is the daily 'reservoir' effect of the trickle vents that purge the room overnight and provide a room full of fresh air ready for the following day's occupants. The larger the room volume, as with the higher ceilings in naturally ventilated rooms, the longer this reservoir effect will last during the occupied period. As trickle vents are intended to promote background ventilation only, their main application is for fresh air supply in the winter months. Twenty-four-hour use of trickle ventilation can provide a reservoir of fresh air that may be sufficient to maintain air quality throughout the day. With higher pollutant loads, rapid ventilation by opening windows for short periods or by mechanical ventilation might be required. For this reason, trickle ventilators are usually used in conjunction with other types of ventilation opening.

Trickle vents can be in the window frame, part of the glazed unit or independent of the window (usually above it). Various refinements on the basic trickle ventilator are available. Acoustic trickle ventilators are available that reduce noise, but they bring a penalty of increased pressure drop.

Control options available include the following.

- *Basic (uncontrolled)*: consisting of a series of holes or slots that are covered to give protection from the weather. No control is possible, hence positioning and appropriate selection are very important.
- *Standard controllable (including 'hit and miss')*: closure may be possible through the use of a manually operated slide that covers the openings. Occupants need to understand the operation of such devices.
- *Humidity controlled*: mostly used in kitchens and bathrooms within dwellings, as the scope for use in offices is limited with moisture not being the dominant pollutant.
- *Pressure controlled*: generally used in offices; inside/outside pressure difference is one possible control strategy.
- *Pollutant (e.g. CO<sub>2</sub>, CO, smoke controlled)*: used in schools, theatres, shopping malls etc. and sometimes in dwellings. Practical use for offices is limited as, except for CO<sub>2</sub> (where considerable drift has been reported), these are not normally the dominant pollutants.

The ventilation performance of trickle ventilators is traditionally specified in terms of 'free air space' or 'open

area'. Acoustic effectiveness is considered in the light of the 'effective area' or 'equivalent area'. This is considered in detail in BRE guidance (BRE, 1998).

Effective area is also considered to be a more realistic measure of airflow performance. It is defined as the area of a single sharp-edged hole (in a thin plate) that passes the same volume airflow rate and at the same applied pressure difference as the vent being tested. It requires to be measured on an airflow test rig. Most trickle ventilators with the same equivalent area will have similar airflow performance, even though their free areas might differ. Consideration of effective area is now required in Part F of the Building Regulations (NBS, 2013b).

### 2.6.9.3 Louvres

These are usually constructed of either glass or aluminium blades. Security bars can be fitted inside the louvres and this enhances their potential application in the night ventilation mode. Versions incorporating acoustic attenuation are also available. Whilst providing good control over summer ventilation, adjustable louvres usually present the greatest crack length for a given opening. However, conventional hinged louvres are usually difficult to seal when closed, making it difficult to limit infiltration losses.

### 2.6.9.4 Roof ventilators

In combination with low-level openings in the fabric, roof ventilators can be used to take advantage of summer stack effect, particularly for tall spaces. However, they must be specified to have low crack leakage or wind-induced draughts will cause discomfort in winter.

For maximum effect the outlet should be on the ridge of a pitched roof and the cap should project sufficiently above the ridge to minimise the influence of turbulence arising from wind blowing up the slope of the roof. Natural ventilation openings should try to avoid being installed on the slope of a roof and avoid being located in high-pressure areas of the building environment, where down-draughts are likely to occur.

### 2.6.9.5 Fixed lights

Crack leakage from roof lights should not be relied upon to provide ventilation even though minor leakage may arise along the crack length of the perimeter.

### 2.6.9.6 Dampers

Dampers are usually used for applications where automatic control is required. In the context of natural ventilation, this is usually for air inlets, both side-wall mounted above and below false floor level and at main exhaust points (e.g. roof vents). Again, the key performance criterion is the ability of the damper to provide an airtight seal when closed to minimise energy losses. If effective control is required then a significant proportion of the available pressure differential must occur across the damper in order to provide control authority.

### 2.6.9.7 Dampened openings with louvres

There are dampened openings available that are fixed to the outside building façade and protected from water ingress by a suitable weather-protective louvre. Such systems take advantage of either the stack or mixed-mode principle and manufacturers have developed decorative internal cover grilles if the opening is within the occupied space and even allowed for low-pressure hot water (LPHW) coils to be used in conjunction with these to temper the incoming air for winter conditions and prevent cold slugs of air entering directly into the room.

### 2.6.9.8 Acoustic dampers with silencers

Internally where the air passes through the building exchanging from room to room or room to atrium, an acoustic damper (Figure 2.57) may be required as a control point for the design of the system. This may require additional silencers to perform to the relevant space-required noise standards but the dampers with acoustic properties should be reviewed for their initial performance.

### 2.6.9.9 Shafts and ducts

Many ventilation strategies rely on shafts to take air vertically through a building. Similarly, ducts (including floor voids) are used to provide horizontal distribution. The criteria for sizing these airways are very different to those used in sizing conventional mechanical ventilation systems in order to keep pressure drops within the range available from natural driving forces. This means that adequate space must be allowed to incorporate these larger ducts or shafts. A second crucial issue is the requirement to keep the inlet ducts clean to minimise air-quality problems. This will typically require inlet screens and access for cleaning.

By definition, shaft outlets are at high level and therefore are in a region of higher wind speed. This means that the magnitude of the wind pressure acting on the shaft is likely to be large. Wind effects will probably dominate the pressure distribution through the system except at very low wind speeds. It is therefore vital that outlets are designed to create wind pressures that reinforce the intended flow direction. Usually this means creating a negative pressure coefficient at the top of the shaft, the exception being the wind scoop.

Orme *et al.* (1994) provide information on the above roof pressure coefficients. For isolated buildings with no local flow interference, the minimum height of the stack above roof level to avoid back-draughts is given by:

$$h = a [0.5 + 0.16 (\theta - 23)] \quad (2.36)$$

where  $h$  is the height above roof level (m),  $a$  is the horizontal distance between the outlet and the highest point of the roof (m) and  $\theta$  is the pitch of the roof (degrees).

For roof pitches of less than 23°, the height of the outlet must be at least 0.5 m above the roof level. These simplified relationships represent a minimum stack height; greater heights may well provide higher suction pressures. This can be beneficial since it is possible to generate a suction greater than that generated on an opening on the leeward vertical face of the building.

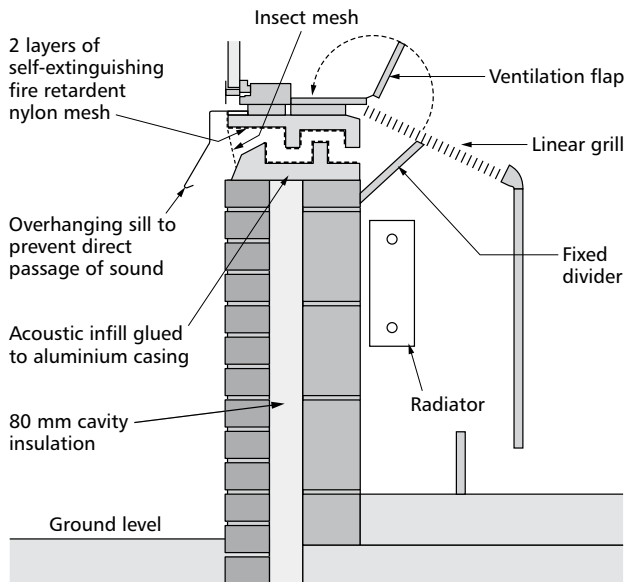

**Figure 2.57** Ventilation opening with acoustic protection, based on an illustration from BB93 (EFA, 2004)

More information on pressure coefficients over roofs is given in BS EN 1991-1-4: 2005 + A1: 2010: *Eurocode 1. Actions on structures. General actions. Wind actions* (BSI, 2005c). For complex roof profiles or where surrounding buildings or other obstructions disturb the wind, model testing would be advisable.

As well as the position of the roof outlet, the geometry of the outlet will also affect the pressure coefficient. The outlet should prevent rain entering the stack and can provide flow acceleration local to the outlet to further reduce static pressures.

#### 2.6.9.10 Transfer grilles

Transfer grilles may be required as a minimum to allow air movement across a building if cellular accommodation has been provided. The resistance of these transfer grilles must be included in the design calculation when sizing the façade unit sizes.

#### 2.6.9.11 Wind towers

Wind towers are variously referred to as windcatchers and wind scoops. These are derived from ancient Middle East 'badgir' systems in which a rectangular cross-section chimney is divided by diagonal quadrants into four ducts. Each is exposed to its own opening at the top of the chimney and to a diffuser at its base (see Figure 2.58). Depending on wind direction, positive pressure drives air through the wind-facing quadrants while suction pressure extracts air through the remaining quadrants. In desert regions this took advantage of high-level wind while minimising the risk of sand being driven into the building, as would occur through low-level openings. These devices are multi-directional and function irrespective of wind direction, as any of the four faces can allow supply air to be introduced and to pressurise the room below, with the opposite louvre face achieving a negative pressure and acting as an exhaust louvre. Various manufacturers have developed modern versions of this system. Specific manufacturers' details

should be reviewed to check performance criteria are met with this method.

In climates where the balance of driving force varies between wind and temperature, the flow patterns become complex and these devices can perform both as wind towers and chimney stacks according to the net driving force (see section 2.4.6). In terms of mathematical analysis, the opening heights, dimensions and orientation can be treated in exactly the same way as any other natural opening as described in chapter 4 of CIBSE Guide A (2015a) and section 2.4.6. Modern designs focus on reducing the aerodynamic resistance and pressure drops across components. In critical cases, performance data should be independently evaluated by laboratory testing. Flow resistance usually restricts the depth of penetration to two stories. As with chimneys and atria, they can be used to assist in deep-plan natural ventilation.

External roof-mounted terminals have been developed to take advantage of the wind-tower principle and allow a constant airflow relating to wind-driven forces. These terminals take the form of an exposed, roof-mounted, four-sided louvre screen with appropriate weathering properties and suitable roof section. The internal section of the louvre is split into four separate sections across the corners of the terminal to allow wind to penetrate at least one side of the face of the terminal positively and allow air to enter the building and pressurise the room below positively. This creates a negative pressure on the opposite side of the terminal, allowing exhaust warmer air to be evacuated and replaced with the fresh air supplied. These terminals are multi-directional.

#### 2.6.9.12 'Passive' stacks

Stack ventilation can be enhanced by using passive stacks (see Figure 2.59). These are vertical ducts that are typically 100–150 mm in diameter. The lower end terminates in the ventilated space at or close to ceiling level. The upper end penetrates the roof and is ideally located in the wind-

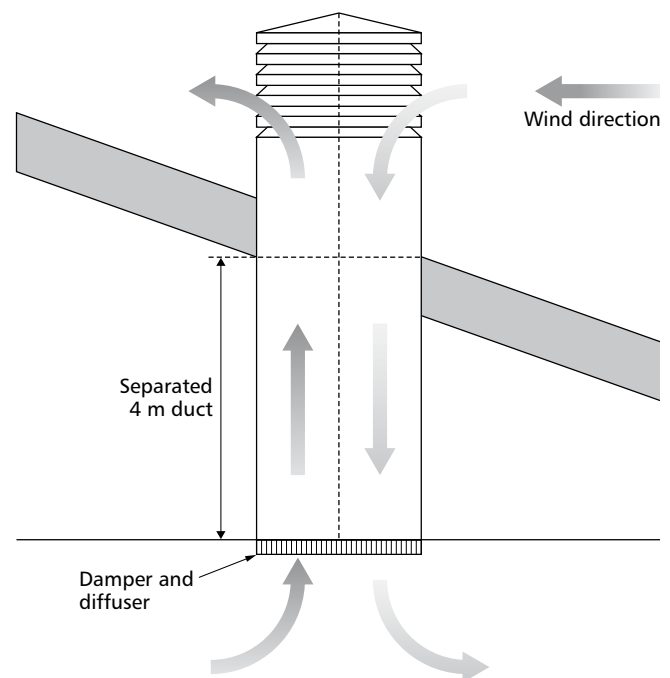

**Figure 2.58** A roof mounted wind tower, reproduced from AM10: *Natural ventilation in non-domestic buildings* (CIBSE, 2005)

generated suction region so that ventilation can be driven by both wind and stack-driving forces. Make-up air is provided by trickle ventilators. The essential requirement is for the air in the chimney to be warmer than the ambient air. In dwellings, stacks are placed in 'wet' rooms and 'dry' air is drawn from the living and bedrooms.

Standard passive stack ventilation (PSV) systems have a simple inlet grille to the duct. Humidity-sensitive vents are available that can provide increased flows when humidity is high. Acoustic treatment may be required to reduce ingress of external noise. Fire dampers are required where ducts pass through a fire-separating floor.

For guidance on sizes and available products, manufacturers will be able to advise on the maximum and minimum duct sizes to handle the required airflow through the stack or chimney. Manufacturers can calculate driving forces and select suitable equipment to achieve the desired results and prove this system will be able to cope with the required specification.

It is possible to enhance the stack pressures by means of absorbing solar gain (the so-called 'solar chimney') introduced via glazed elements. Location of the solar stack on the sunny side of the building in order to capture the solar radiation will generally result in cooler air being drawn in from the opposite shaded side. Solar performance requires careful thermal analysis because it relies on a rapid rate of heat transfer from the solar heated components to the raising ventilation airstream.

Care should be taken to ensure that there is a net heat gain into the chimney during cooler weather, i.e. the solar gain must be greater than the conduction loss. In cold weather, the conduction heat loss will result in low surface temperature for the glass that may be sufficient to generate down-draughts inhibiting the reverse of the general upward flow through the chimney. The wind-driving pressures can be enhanced by careful design of the roof profile and/or the chimney outlet configuration.

As a means of providing adequate ventilation on very hot and still days, consideration should be given to installing

extract fans in the stack to pull air through the building. However, the fan should not provide a significant resistance to flow when the chimney is operating in natural draught mode and noise should be carefully considered (see section 2.3.2.4).

The analysis on stack ventilation often makes the presumption that the air in the stack is at building temperature and outside air is at a lower temperature. A steady reverse-flow pattern, with outdoor airflow down the stack, is possible if the stack was to assume the outdoor rather than indoor temperature. This can occur, for example, if the building has been allowed to cool during unoccupied periods (e.g. weekends or over night). Reverse flow should be avoided in cold weather but it can be used to advantage at night in the warmer seasons where free cooling may be available due to the night-time drop in temperature. This allows air to be drawn into the building at lower than occupant comfort temperatures thus allowing the building to cool significantly prior to the next day's expected elevated temperatures. More technical information on reverse flow in stacks is published by Li (2002).

## 2.7 Commissioning, operation and maintenance

### 2.7.1 Testing and commissioning

#### 2.7.1.1 Introduction

All ventilation systems and associated ductwork systems should be tested and commissioned, and those of significant size (e.g. with a fan capacity above  $1 \text{ m}^3\text{-s}^{-1}$ ) should also be leak tested. The needs of on-site regulation should be planned and provided for in the design stage, otherwise balancing the system within acceptable limits may not be possible. The designer must accept the implications of the commissioning procedures to which the air distribution system will be subjected. Inadequate commissioning will

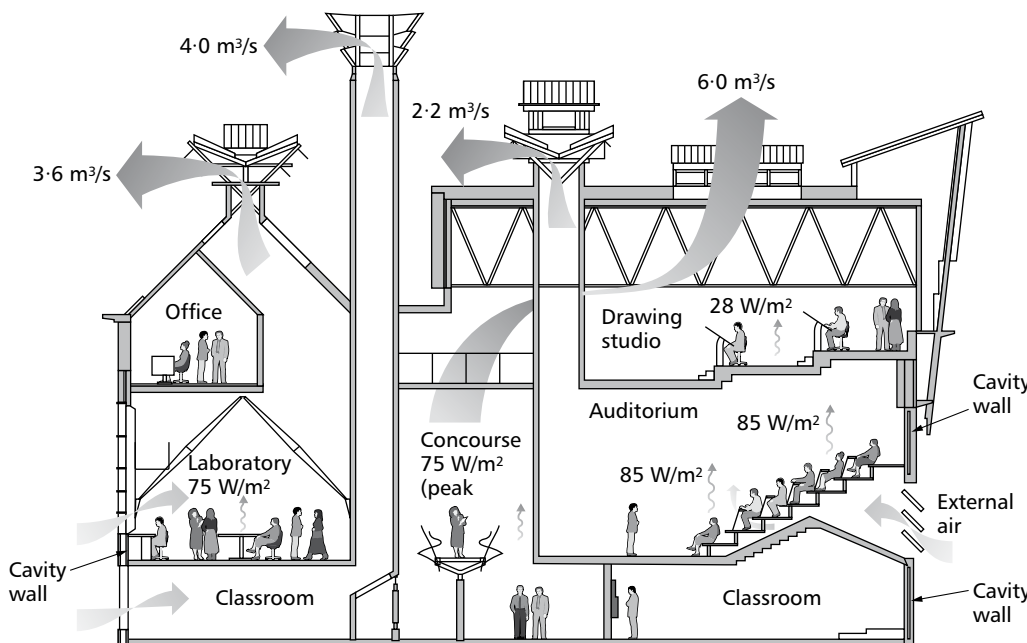

**Figure 2.59** An example of a design using a passive stack system to enhance natural ventilation; Queens Building, de Montfort University (reproduced courtesy of Short Ford Architects)

result in poor environmental performance, energy wastage, draughts and noise. The designer's objectives must be to design an air distribution system where arrangements of ductwork and the selection and disposition of the components, particularly the means of air regulation, will promote a balanced and stable airflow. In the UK commissioning is explicitly included in the Building Regulations.

The measuring, regulating and apportioning of airflow in a distribution system are a means to an end. The objective is to ensure that the performance of the commissioned installation is adequate to maintain the specified environmental conditions of the space with optimum efficiency.

Procedures for commissioning air-handling systems are given in CIBSE Commissioning Code A: *Air distribution systems* (2006b) and BSRIA AG 3/89.3: *Commissioning Air Systems* (2001). Table 2.42 shows a summary of the flow-measuring techniques recommended by BSRIA for various ducts and terminals.

Before system regulation starts, the building needs to be complete, with windows and doors open or shut according to their normal state. The air distribution system needs to be complete, with leakage testing satisfactorily concluded. A reasonable standard of system cleanliness should be achieved before system start up.

Each system should be considered on its own merits and a detailed commissioning method statement produced and agreed prior to commissioning. It is important that the designer provides full information on all relevant aspects of the design, particularly VAV systems, in sufficient detail for the commissioning specialist to produce a comprehensive method statement. The commissioning specialist should review the recommendations of the equipment suppliers with regard to the inclusion of their equipment in the commissioning process for the air distribution system.

Successful commissioning and building operation depends on the following design considerations.

- Avoid long duct runs, since these can create balancing difficulties in commissioning.
- The use of variable speed fans allows rapid matching of fan duties during commissioning.
- Ensure there are sufficient dampers and access panels to reduce commissioning time.
- The setting of the automatic control system should be finalised by the controls specialist in liaison with the commissioning specialist.

### 2.7.1.2 Legislation

CIBSE Commissioning Code M: *Commissioning management* (2003) provides an overview of the management arrangements for commissioning required to ensure compliance with Parts F (NBS, 2013b) and L (NBS, 2013a) of the Building Regulations. Steps include:

- design for commissioning
- co-ordination of the commissioning process
- installation quality assurance
- pre-commissioning
- preparation

- commissioning
- confirming compliance
- certification
- building log book (CIBSE TM31: *Building log book toolkit* (2006c))
- system handover.

Building Regulation 38 (TSO, 2010) requires the handing over of all design, installation positioning and maintenance information for any and all fire safety items.

### 2.7.1.3 Design provisions to facilitate commissioning

#### Introduction

Consideration should be given to access for commissioning, inspection, maintenance and cleaning. Openings need to be safe and have sealed panels/covers designed so that they can be easily removed and refixed. Multiple setscrews are not recommended, and self-piercing screws are not acceptable as a method of fixing. Safety restraints should be connected to access panels located in riser ducts.

A sufficiently large area, free of services and other obstructions, is needed around panels and covers to allow them to be removed.

An access panel is required to be adjacent to items of in-line equipment that require either regular servicing or intermittent access. The openings need to be sized as a minimum to allow hand and/or arm access. The designer should specify the size and location of the panels where larger dimensions are required. In these cases the panels should not exceed 450 mm × 450 mm. It may be more practicable to use removable duct sections or flexible ducts/connections.

An inspection panel should be provided adjacent to items of in-line equipment that need only visual inspection of internal elements from outside the ductwork. Such inspection openings should have a minimum size of 100 mm × 100 mm for rectangular ducts and 100 mm diameter for circular ducts.

It will be the responsibility of the insulation contractor to 'dress' the insulation to the edges of the access openings without impeding the functionality of the panel, cover or door.

#### Provision of access panels

Access panels should be provided for the inspection and servicing of plant and equipment; Table 2.45 provides guidance. However, the ductwork system designer may choose to demonstrate that adequate provision has been made for access, such as by reference to a ductwork cleaning specialist.

In addition, the following should be noted.

- Fire/smoke dampers: panels should be located to give access to both the blades and the fusible links. On multiple assembly units it may be necessary to provide more than one panel; the need for such access may be determined by the external access

**Table 2.42** Flow measurement techniques (reproduced from BSRIA AG 3/89.3: *Commissioning Air Systems* (2001) by permission of the BSRIA)

Position	Measurement technique	Instruments
Main duct (total flow at fan)	* Velocity traverse in duct	Pitot tube with micromanometer
	† Wilson flow grid	Micromanometer
Branch ducts	* Velocity traverse in duct	Pitot tube with manometer
Terminal connecting ducts	* Velocity traverse or single point reading in duct	Pitot tube with micromanometer or mini-rotating vane anemometer where velocity < 4 m·s <sup>-1</sup>
Grilles	* Velocity traverse across face	Rotating vane anemometer
	* Hood	Rotating vane anemometer or integral hood assembly
Ceiling diffusers	* Flow hood	Rotating vane anemometer or integral hood assembly
	* Velocity in connecting duct	Pitot tube/manometer or mini-rotating vane anemometer
	* Static pressure in connecting duct	Diaphragm pressure gauge or pitot tube
Slots and linear diffusers	† Average peripheral velocity and area	Mini-rotating vane anemometer or thermal anemometer
	* Face velocity (for slots of equal width and same louvre setting)	Mini-rotating vane anemometer or thermal anemometer
	* Flow hood	Rotating vane anemometer or integral hood assembly
Perforated ceiling	† Velocity in connecting duct	Pitot tube/manometer or mini-rotating vane anemometer
	* Velocity in connecting duct to ceiling void	Pitot tube/manometer or mini-rotating vane anemometer
Perforated panel diffuser	* Velocity in connecting duct	Pitot tube/manometer or mini-rotating vane anemometer
	* Flow hood	Rotating vane anemometer or integral hood assembly
	† Face velocity (no deflection)	Rotating vane anemometer or integral hood assembly
Decorative terminals	* Velocity in connecting duct	Pitot tube/manometer or mini-rotating vane anemometer
Induction units	* Static pressure in nozzle plenum	Diaphragm pressure gauge
High velocity nozzles	* Jet velocity	Pitot tube/manometer or mini-rotating vane anemometer
	* Static pressure in connecting duct; previous calibration or maker's data	Diaphragm pressure gauge
Fan coil units	* Velocity in connecting duct	Pitot tube/manometer or mini-rotating vane anemometer
Extract openings (grilles)	* Face velocity	Pitot tube/manometer or electronic hood
Slots, perforated panels, decorative openings	* Velocity in connecting duct	Pitot tube/manometer or mini-rotating vane anemometer
Combined lighting units, adjustable exhaust valves	* Manufacturer's recommended technique	Pitot tube/manometer or mini-rotating vane anemometer
	* Velocity in connecting duct	

Note: \* indicates preferred measuring technique for stated location

† indicates second choice (i.e. more difficult to use in practice or subject to a greater possibility of error)

conditions and the internal reach to the blades and their fusible links.

- Heating/cooling coils and in-duct fans/devices: the panel should be located on the air entry side i.e. upstream.
- Filters: panel should be located in the air entry side i.e. upstream (note: dimensions of access may need to be changed to suit filter elements of the front withdrawal type).
- Inspection covers: inspection covers should be provided adjacent to regulating dampers where either the control linkage is mounted internally within the airstream or if a multi-bladed unit is an integral part of the ductwork run. It is not necessary to provide inspection covers adjacent to either single blade regulating dampers or flanged damper units.
- Hand holes: hand holes to permit proper jointing of duct sections should be provided at the

manufacturers' discretion but kept to a minimum and made as small as practicable. The hand-hole cover should be sealed and securely fastened.

Cleaning of ductwork must be taken into account in the design and installation stages by ensuring adequate and safe provision is made for access.

Filter removal and replacement must be considered by ensuring sufficient space and means of access is provided.

#### *Good ductwork design*

The duct sizing procedure (see section 2.3.5) should take into account the requirements of system balancing. The position and number of regulating dampers included in the design should be sufficient for this purpose.

**Table 2.43** Information to be provided in schematic drawings

Items of system	Information to be provided
Fans	Fan total pressure Volume flow rates Motor current
Plant items	Type and identification numbers from equipment schedules Volume flow rates Pressure losses Dry-bulb temperatures Wet-bulb temperatures Humidity
Dampers (including motorised) and fire dampers	Identification numbers from equipment schedules Location Volume flow rates
Main and branch ducts	Location Dimensions Volume flow rates
Terminals	Identification numbers from equipment schedules Location Dimensions Volume flow rates and velocities Operating pressures
Test holes and access panels	Location
Controllers	Set points

**Notes:**

- (1) Fan total pressure is the difference between the total pressure (static pressure + velocity pressure) at the fan outlet and the total pressure at the fan inlet.
- (2) Where volume flow rates are variable, maximum and minimum values should be provided.

**Communication**

The designer should pass on the design intent to the commissioning engineer by indicating which parts of the system are high, medium and low pressure, and by providing:

- relevant parts of the specification
- schematic drawings as listed in Table 2.43 (see also Figure 2.60 below, which shows a basic schematic for system regulation including damper positions)
- equipment schedules
- controller and regulator schedule
- fan performance curves
- wiring diagrams for electrical equipment, including interlock details
- manufacturers' operating and maintenance instructions.

The information listed above should also be included in the building's log book.

**Provision and siting of volume control dampers**

*Note:* it is important to have a means of recording the positions of volume control dampers that have been set during commissioning; spray paint over the quadrant is effective for smaller sizes of dampers.

**Low- and medium-pressure systems**

Manually operated balancing dampers are generally needed:

- (a) in the main duct downstream of the fan
- (b) in the branch or zone ducts
- (c) in sub-ducts serving four or more terminals
- (d) at terminals not covered by (c) above.

Dampers integral with terminals should only be used for final trimming of air volumes, or noise and air distribution problems may result. Dampers should not be used for primary duty control

**High-pressure systems**

Where pressure reduction in a high-pressure system is essential, it is recommended that:

- throttling dampers should not be used in high-pressure and high-velocity sections because of duct leakage and noise problems; if this cannot be avoided then additional attenuators and external sound barrier mats may be needed at the damper and downstream to limit noise break-out
- orifice plates or proprietary pressure-reducing valves should be used as first choice in main branches
- where dampers are required they should be confined to areas of relatively low duct velocities; iris type in circular ducts, streamlined blade construction in rectangular ducts.

**Variable volume systems**

Rather than using throttling dampers in the main duct, system static pressure control in VAV systems should be effected by:

- variable speed motors on the fan(s) or
- inlet guide vanes with centrifugal fans or
- variable pitch blades on axial-flow fans.

**Motorised dampers**

Motorised dampers for throttling airflow should be opposed-blade type opening through a full 90°; for mixing purposes they should be parallel-blade type opening only through 60°.

Throttling dampers should be sized to have an authority of 5–8 per cent of the fan total pressure. Mixing dampers should be sized to have a face velocity of 4–10 m·s<sup>-1</sup>. To obtain maximum benefit from outside air cooling, fresh air/

recirculation air dampers must have a good shut off; this means they should:

- be rigid with accurate square connections
- be provided with end and edge seals of flexible material
- not be distorted during fitting.

**2.7.1.4 Instrument connections**

Instrument connections should be provided at locations determined during the design process.

*Openings required for other purposes*

It is the designer’s responsibility to specify the location and size of any openings required other than those covered in this section. In the case of hinged access doors it is the designer’s responsibility to indicate on the drawings the location and size of hinged access doors required, ensuring that there is an area free of services and other obstructions to enable the door to be satisfactorily opened. Unless otherwise specified by the designer, openings should not be larger than 1350 mm high and 500 mm wide. Doors should open against the air pressure. Both the opening in the duct and the access door itself need to be adequately reinforced to prevent distortion. A suitable sealing gasket should be provided, together with sufficient clamping type latches to ensure an airtight seal between the door and the duct.

For safety reasons, the manufacturer should incorporate means to prevent personnel being trapped inside the duct, for example by providing access doors with operating handles both inside and outside the duct.

**2.7.1.5 Test holes**

*General*

Except in special circumstances, it is not usual practice to install airflow measuring devices permanently in air ducts. The normal procedure is to make velocity traverses across the duct at appropriate locations using a pitot tube. The small test holes for using a pitot tube are usually made by the commissioning specialist.

Test holes for in-duct measurement are needed on the main duct following the air-handling plant. The basic locations for siting test holes for flow measurement are shown in Figure 2.61 as ‘principal measuring points’. If there is insufficient space, an alternative is to provide test holes in principal branches so that the total flow from the fan can be obtained by summation. These points are shown in Figure 2.61 as ‘secondary measuring points’.

Test holes for in-duct airflow measurement are required:

- on both sides of the fans and heating and cooling coils (for pressure drop measurement)
- in the main ducts

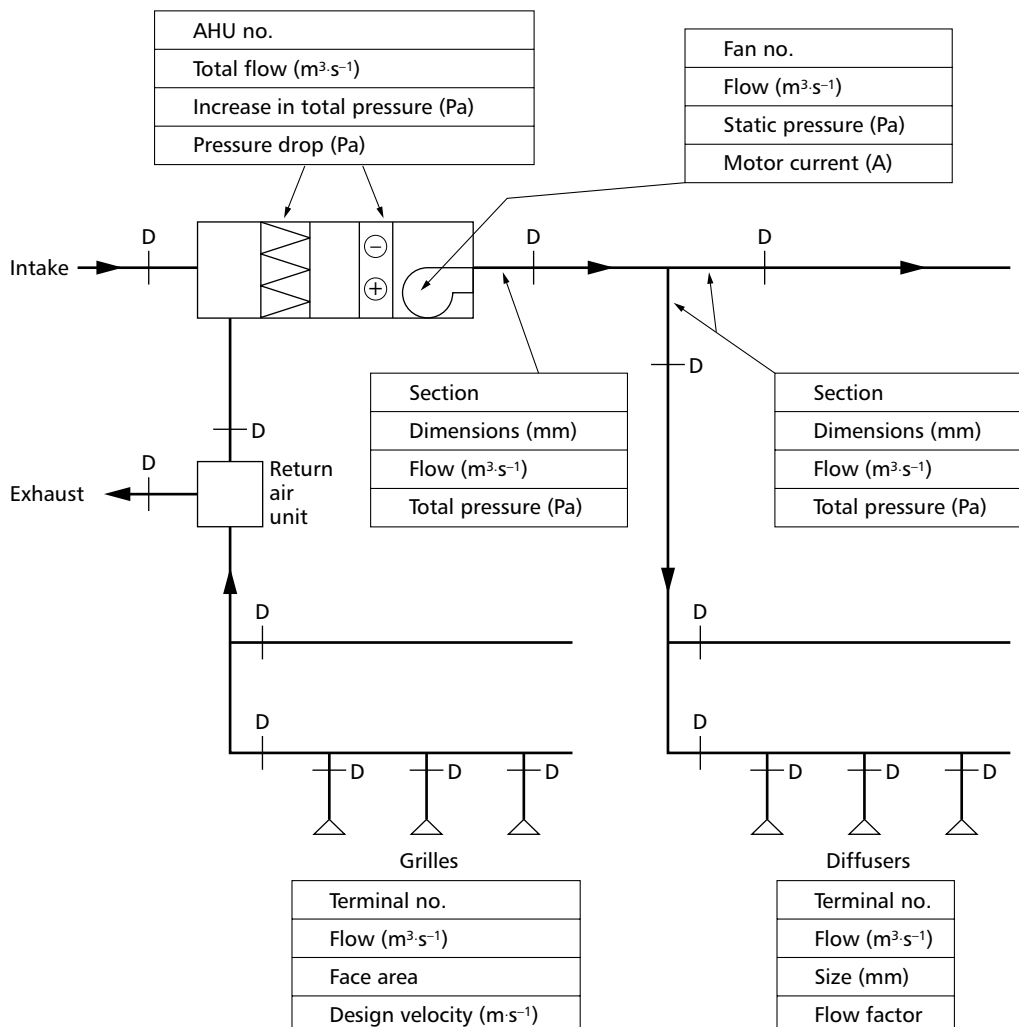

**Figure 2.60** Basic schematic for system regulation showing damper positions (reproduced from BSRIA AG 3/89.3: *Commissioning Air Systems* (2001) by permission of BSRIA)

- in all branches
- in centrifugal fan drive guards opposite the end of the fan spindle, for speed measurements.

The number and spacing of holes at a particular location are given in BSRIA AG 3/89.3: *Commissioning Air Systems* (2001); these recommendations are summarised in Table 2.44 and Figure 2.62.

The location chosen for the measurement point should be:

- at least 1.5 duct diameters upstream of sources of turbulence such as dampers and bends; if this is not possible then well downstream of these sources
- where there is enough space around the duct to insert the pitot tube and take readings
- where the duct has a constant cross-sectional area.

Minimum distances of test holes from sources of turbulence are given in Figure 2.62.

#### Test hole specification

The main test hole locations are shown in Figure 2.61. Usually the installer will not have drilled the test holes, this being left to the commissioning specialist. However, the designer and the installer should have taken account of the location of test holes to ensure access. It is sometimes appropriate to use re-sealable test holes, included in the ductwork prior to installation.

Figure 2.62 shows the minimum distance of test holes from sources of turbulence. Figure 2.63 gives the dimensions of a standard test hole for a pitot tube for in-duct measurement.

For rectangular ducts, the number of test holes depends on the duct dimensions. For circular ducts, a single test hole is required for ducts less than 150 mm in diameter, and two holes spaced at 90° are required for larger ducts. The appropriate position, number and spacing of test holes are given in BSRIA AG 3/89.3: *Commissioning Air Systems* (2001).

#### 2.7.1.6 Cleanliness of new ductwork and components

The designer should specify the requirements for:

- cleanliness levels for ductwork leaving the factory
- protection during transit
- protection during site storage
- protection of ductwork risers
- inspection and cleaning during installation and before handover.

TR/19: *Guide to Good Practice: Internal Cleanliness of Ventilation Systems* (BESA, 2013c) provides for three grades of pre-commission cleanliness. The designer should determine which is appropriate for the specific installation and state this in the design specification.

In manufacturing ducts, attention should be paid to the grease used in production. The ductwork should leave the factory as clean and dry as possible. Any remaining grease film is a potential base for microbial growth.

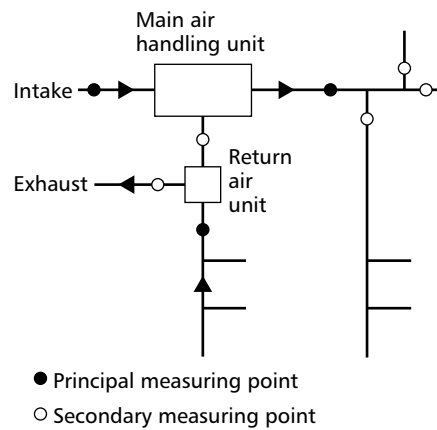

Figure 2.61 Basic test hole positions for flow measurement in duct systems (reproduced from BSRIA AG 3/89.3: *Commissioning Air Systems* (2001) by permission of BSRIA)

The whole ductwork installation should be inspected and, where necessary, cleaned before handover. The preferred cleaning method should be specified in the handover documents, including guidelines on access to all points to be cleaned.

During installation the installer should ensure that dust and debris are prevented from entering the ductwork system to ensure that the installation is clean prior to commissioning. The commissioning process should include an inspection of ductwork cleanliness. Where this is not the case, it may be necessary to employ a specialist ductwork cleaning company. The commissioning should not commence until cleanliness has been inspected and certified. The installation should be in a clean state at handover.

Inspection of the ventilation system will usually start with a visual check of the outside air intake, which can be a source of pollution and contamination. A smoke test can quickly determine if outside air is entering the system. Further items to check will be dampers, protective devices against weather, insect and rodents, the hygiene of coils, fans and insulation, the presence of water and condition of condensate drain pans and humidifier reservoirs.

Checking the need for cleaning should be done periodically. Eurovent includes recommendations on indoor air quality (IAQ) (Eurovent, 1999).

## 2.7.2 Maintenance and cleaning

### 2.7.2.1 Introduction

Over time, the performance of ventilation systems will deteriorate. The designer should be aware that the air distribution system may become a major odour source. It is possible, with regular cleaning and maintenance, to eliminate nearly all the odour emissions from the system, in both new and renovated buildings.

Components will need regular servicing and replacement to prevent failure. In addition, contaminants such as bacteria, fungal spores, skin scales, dust and moisture could contaminate the ductwork and clog filters. Regular maintenance and cleaning are therefore needed to ensure the correct and efficient operation of the ventilation system.

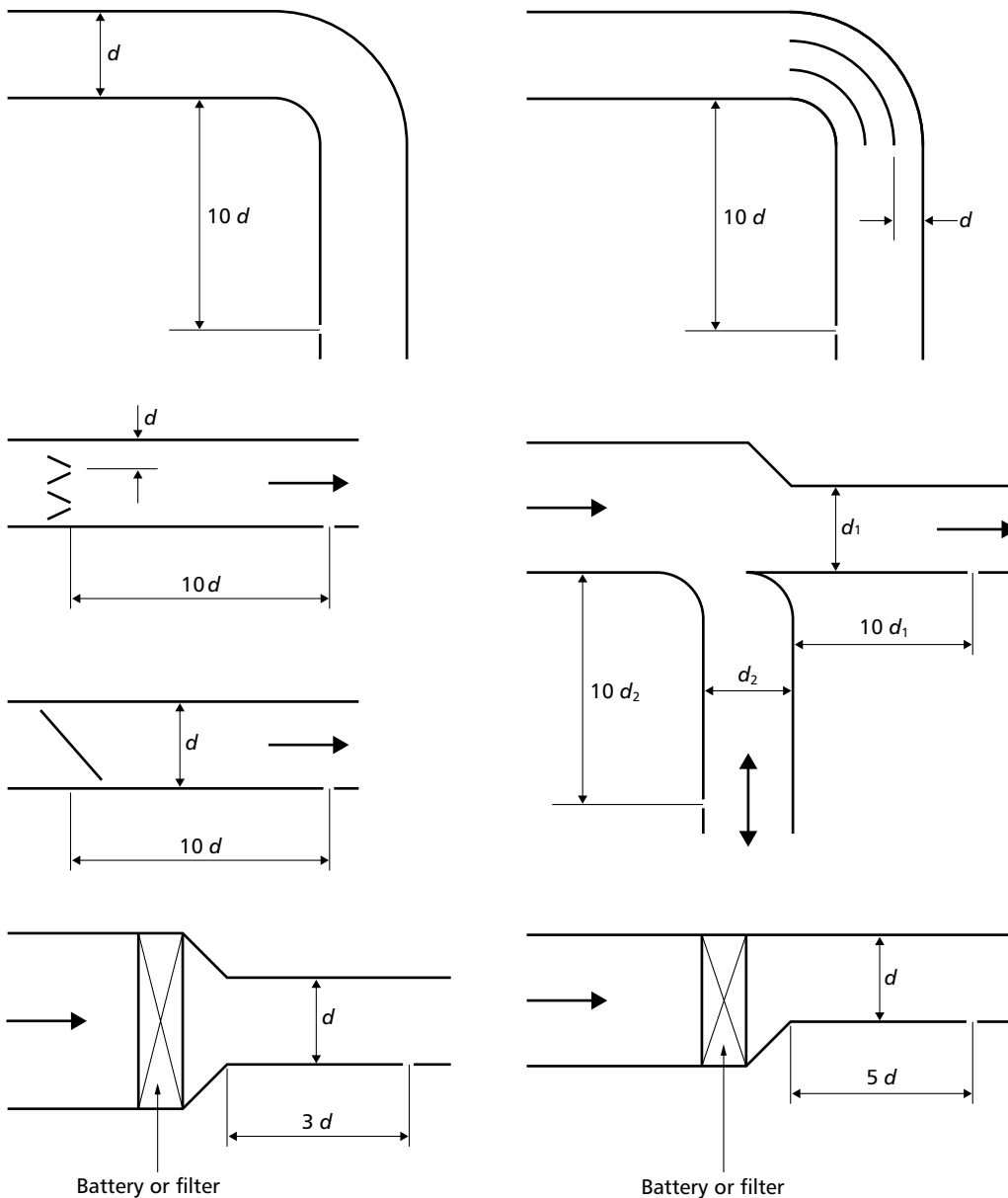
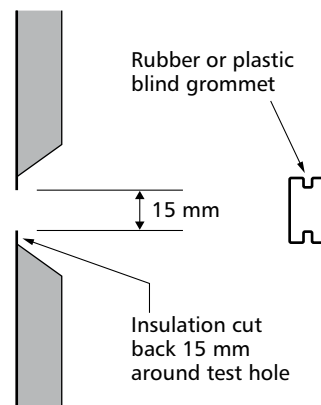

**Figure 2.62** Minimum distance of test holes from sources of turbulence (reproduced from BSRIA AG 3/89.3: *Commissioning Air Systems* (2001) by permission of BSRIA)

**Table 2.44** Test hole positions; special requirements for the measurement of total airflow from the fan (reproduced from BSRIA AG 3/89.3: *Commissioning Air Systems* (2001) by permission of BSRIA)

Type of fan	Position of test holes*	
	Upstream	Downstream
Centrifugal	4 d	10 d
Axial:		
— single stage	4 d	Not advised
— single stage with guide vanes	4 d	10 d
— two-stage, contra-rotating	4 d	10 d

\* d = diameter (equivalent diameter for non-circular ducts) of duct following the fan



**Figure 2.63** Dimensions of standard test holes (reproduced from BSRIA AG 3/89.3: *Commissioning Air Systems* (2001) by permission of BSRIA)

Steps include:

- repeating commissioning exercises
- cleaning
- scheduled replacement of components (filter etc.)
- identifying and rectifying faults.

### 2.7.2.2 Legislation

The EU Workplace Directive has been implemented in the UK by the Workplace (Health, Safety and Welfare) Regulations (HMSO, 1992). The Health and Safety Commission's Approved Code of Practice and guidance L24 (HSE, 1994) states that: 'Mechanical ventilation

systems (including air-conditioning systems) should be regularly and properly cleaned, tested and maintained to ensure that they are kept cleaned and free from anything which may contaminate the air.' This has applied to all workplaces since January 1996. Additionally, provision for access space for maintenance of the ventilation systems will need to be considered at the design stage. Inspection requirements are also enshrined in the European Energy Performance of Buildings Directive (EPBD) (EU, 2010).

The Regulatory Reform (Fire Safety) Order 2005 (TSO, 2005) requires a responsible person to implement risk assessments on all areas for fire. In addition, they should maintain all fire safety installations and keep records about all such items.) See also Building Regulation 38 (TSO, 2010).

### 2.7.2.3 Maintenance

#### Cleaning

Ventilation components and ductwork systems should be clean on completion (see also BS EN 15780: 2011: *Ventilation for buildings. Ductwork. Cleanliness of ventilation systems* (BSI, 2011b)). TR/19: *Guide to Good Practice* (BESA, 2013c) says that where specific verifiable levels of internal cleanliness are required it will be the responsibility of the designer to specify the inclusion of a specialist cleaning contractor.

During use over a number of years, a slow build-up of deposits can occur, particularly at points where the air velocity reduces. More rapid build-up of dirt will result when filters are faulty or damaged, poorly installed or badly maintained.

See 'Testing, commissioning, cleaning and maintenance' in section 2.3.5.2 for information on ductwork cleaning methods.

Special requirements apply to cleaning and maintenance of ductwork in applications such as food preparation (see DW/171: *Standard for Kitchen Ventilation Systems* (HVCA, 2000)), process industries and plant rooms. Detailed maintenance requirements for ductwork are set out in SFG20: *Standard Maintenance Specification for Building Services* (BESA, 2012).

When undertaking maintenance work within ducts, it is essential that sensor probes are withdrawn to protect them from being damaged.

**Table 2.45** Requirements for access to duct-mounted components

Component	Location of access opening(s)
Dampers	Both sides
Fire dampers	One side
Heating/cooling coils	Both sides
Circular sound attenuators	One side
Rectangular sound attenuators	Both sides
Filter sections	Both sides
In-duct fans	Both sides
Airflow control device	Both sides

#### Design for cleaning

To enable cleaning to be carried out safely and efficiently, it is important that the air distribution system is designed and installed so that all internal surfaces and components can be accessed.

A comprehensive standard for access installation is provided by BS EN 12097: 2006: *Ventilation for buildings. Requirements for ductwork components to facilitate maintenance of ductwork systems* (BSI, 2006b).

Components (for example dampers, sensors, airflow measuring devices) should be installed so that they can be cleaned in situ or removed for cleaning. If removal is not possible, service access should be provided according to Table 2.45. Access should be provided that is not obstructed by suspended ceilings, electric cables, lighting, pipes or other ducts.

Abrupt bends, area reductions and sharp objects, such as projecting screws, inside duct joints should be avoided to prevent injury to maintenance and cleaning personnel. Stiffeners and other equipment inside the ductwork should not obstruct the cleaning process. Access doors and covers should be easy to open and be constructed and installed to match the type and location of any thermal, acoustic or fire insulation.

A ductwork component that can be dismantled for cleaning can also be regarded as an access door on condition that its dimensions are in accordance with Table 2.46 or sufficient for the specified and documented cleaning method. Access to duct-mounted components should be provided in accordance with Table 2.45, unless the component is easily removable for cleaning or can be cleaned through the ductwork without obstructions.

The location of and distance between openings depends on the quality of supply-and-extract air and also on the defined or available cleaning method. Unless the cleaning method is known or can be fixed at the design stage, the distance between the openings should not exceed 10 m or not be more than two  $\geq 45^\circ$  bends.

Designers should take specialist advice and stipulate their requirements for the periodic internal cleaning and maintenance of ductwork.

**Table 2.46** Openings for ducts; recommended minimum dimensions

Duct type and size	Access opening size	
	A/mm	B/mm
Circular ducts (diam. $d$ /mm):		
— $200 < d \leq 315$	300	100
— $315 < d \leq 500$	400	200
— $500 < d$	500	400
— inspection opening	600	500
Rectangular (side length $s$ /mm):		
— $s < 200$	300	100
— $200 < s \leq 500$	400	200
— $s > 500$	500	400
— inspection opening	600	500

### *Air quality and health issues*

The air quality within a building is influenced by contaminants in the form of particles and gases that are generated within the building envelope and those brought in from outdoors. Contaminant particles may enter the building with the outdoor air. These can include carbon produced by combustion and vehicles, and particles of biological origin. Contaminant gases produced within a building include the volatile organic compounds (VOCs) emitted by some construction materials, fabrics and adhesives, and fumes emitted by photocopiers and laser printers. Gases admitted from outdoors include vehicle exhaust gases. Biological agents such as bacteria, fungal spores and pollen grains can enter the building from outside. Particles generated indoors can include human skin scales, bacteria, viruses and fungi, faecal matter from the house dust mite, textile fibres, building materials and paper dust. Settled deposits in ductwork may cause contamination of air supply by release of chemicals such as odorous VOCs, produced either microbiologically or chemically.

Designers do not normally consider the health effects of microbes in ductwork systems, since their focus is the attainment of specified operating conditions, generally for comfort purposes. It is important to be aware of the potential health issues arising from microbial material in ductwork. There are currently no environmental health criteria setting safe microbial exposure. Possible harmful health effects on the occupants of buildings from microbial growth within the fabric include allergies, infection and toxicosis. Further information about these is provided in CIBSE TM26: *Hygienic maintenance of office ventilation ductwork* (2000b).

Ultraviolet (UV) light can be very effective in deactivating pathogens and other airborne bacteria, viruses and moulds. Where a high-quality air supply is required, such as in health-care facilities and situations where there is a high occupation density, UV lamps can be installed in the ductwork. Medium-pressure lamps, e.g. 3.5 kW and 300 mm in length, run very hot and must be switched off when the fan is not operating. Provision of UV lamps will also have implications for maintenance.

### *New ductwork construction*

According to BS EN 15780: 2011 (BSI, 2011b), in the handover documents the cleanliness quality class, cleanliness criteria and measurement methods should be specified; recommendations for cleaning methods and guidelines for reaching the points to be cleaned should also be given.

The design information should give consideration to the expected cleaning method. Where the system has been designed to be cleaned by wet cleaning methods, warnings regarding conditions and restrictions of use should be given. For example, wet methods are applicable only where ducts are sufficiently moisture-tight, internal surfaces are smooth and slope and drainage arrangements have been provided so that fluid and contaminant can be evacuated.

A sufficient number of access doors should be provided in the ductwork. Special care should be taken regarding obstacles to cleaning, such as dampers, sound attenuators etc., which are mounted in the ducts. In many cases,

additional access doors are needed after or before such obstacles, which then can be cleaned carefully. Requirements for location of and distance between access doors are presented in BS EN 12097: 2006: *Ventilation for buildings. Requirements for ductwork components to facilitate maintenance of ductwork systems* (BSI, 2006b) and BS EN 13779: 2007: *Ventilation for non-residential buildings. Performance requirements for ventilation and room-conditioning systems* (BSI, 2007a). Note that it is important that access panels should themselves be reasonably accessible for future maintenance operations.

### *Cleanliness quality classification*

The designer should specify the requirements for the cleanliness quality class to be achieved (see Table 2.47).

The cleanliness quality classification allows the specifier to set measurable maximum acceptable dust accumulation levels, as benchmarks for acceptance.

Annex F of BS EN 15780: 2011: *Ventilation for buildings. Ductwork. Cleanliness of ventilation systems* (BSI, 2011b) provides further guidance on protection, delivery and installation procedures.

### *Existing ductwork*

The normal operation of ductwork systems will introduce dirt both from the external air brought into the system and from re-circulated air containing dust and other particles. The filtration system (where provided) should be designed to remove dirt and dust. However, the level of filtration, the standard of filter medium used and the adequacy of seals and fittings around the filtration equipment can all lead to increased levels of dust and dirt. These in turn can have an effect on plant performance such as reducing the efficiency of the fan and heat transfer equipment. The function of the air movement system and the cleanliness quality class of the building and installation can determine the requirements for cleaning. Certain process applications, for example food and pharmaceuticals, are likely to have considerably higher standards of ductwork cleanliness than those serving a warehouse.

BS EN 15780: 2011: *Ventilation for buildings. Ductwork. Cleanliness of ventilation systems* (BSI, 2011b) provides benchmark measurement levels to define acceptable cleanliness levels for each of the three cleanliness classes and for supply, recirculation and extract.

### *Dust deposition in ductwork*

Dust will generally be deposited mainly over the lower surfaces of air distribution ducts, with the deposition increasing with distance from the AHU. There may be additional deposition where the local flow of air is slowed. This will happen at points where there is a resistance to the flow of air including the filters, heating and cooling coils, corner vanes and changes in the direction of ducting, changes in cross-sectional area and at surface imperfections and jointing cracks between duct sections. Once it is deposited, a physical disturbance or a change in the flow speed would be required to re-entrain significant amounts of the dust into the air.

**Table 2.47** Typical applications of cleanliness quality classes (reproduced from Table A1 of BS EN 15780: 2011: *Ventilation for buildings* (BSI, 2011b) by permission of the British Standards Institution)

Quality class	Typical examples
Low	Rooms with only intermittent occupancy, e.g. storage rooms, technical rooms
Medium	Offices, hotels, restaurants, schools, theatres, residential homes, shopping areas, exhibition buildings, sport buildings, general areas in hospitals
High	General working areas in industries, laboratories, treatment areas in hospitals, high-quality offices

### Moisture

It is important to take precautions to avoid the generation or ingress of moisture, as the presence of moisture or free water droplets on the surfaces of ducts is well known as a potential cause of microbial contamination. This is normally avoided by the system design and control, but unwanted moisture can arise under some circumstances, for example:

- where the metal duct surface temperature falls below the dew-point of the air flowing through it
- downstream of cooling coils operated below the dew-point (a spray eliminator is usually installed downstream of cooling coils used for dehumidification, but 'normal' cooling coils may also operate unintentionally under these conditions)
- where there is a leak of water from a heating or cooling coil or from water pipework outside the air duct
- as a (temporary) residue from any wet cleaning process
- by ingress of rain water.

See section 2.7.2.5 for cleaning methods.

### Fire-resisting products

All fire-resisting products and smoke control items need to be checked regularly and records maintained—see Appendix V and Appendix W of BS 9999: 2008: *Code of practice for fire safety in the design, management and use of buildings* (BSI, 2008a) and the requirements of the RRF50 (TSO, 2005).

#### 2.7.2.4 Inspection for cleaning

Inspection of the ventilation system will usually start with a visual check of the outside air intake, which can be a source of pollution and contamination. A smoke test can quickly determine if outside air is entering the system. Further items to check will be dampers, protective devices against weather, insect and rodents, the hygiene of coils, fans and insulation, the presence of water and condition of condensate drain pans and humidifier reservoirs.

Checking the need for cleaning should be done periodically. Eurovent includes recommendations on indoor air quality (IAQ) (Eurovent, 1999).

Figure 2.64 provides a schematic flowchart for procedures to maintain cleanliness of ventilation systems.

Local exhaust ventilation may be intended to control substances hazardous to health, including biological agents. The Health and Safety Executive (HSE) recommends examination and testing of such systems at least every 14 months and more frequently for certain processes (HSE, 1998).

Ventilation ductwork may be inspected optically using visual inspection instruments (e.g. borescopes) or by remote control inspection vehicles using closed-circuit television (CCTV) to record the internal condition of the ducts. Visual inspection (e.g. video) should be combined with quantitative methods of measuring dirt or microorganisms.

Special attention should be given to the cleanliness of:

- air filters
- sound attenuators
- humidifiers
- components for measurement or control.

The condition of all these items is generally a good indicator of the need for cleaning. It is recommended to start inspection from these components. After cleaning, all these components should be inspected to ensure that no damage has occurred and the cleanliness and functionality are as intended.

The need for cleaning following an inspection of the ductwork will depend on the level of dirt identified at the inspection and the particular requirements of the building, including the specific operations undertaken within the facility. Some buildings will be more sensitive to a build up of dirt and dust in the ductwork and are likely to need a more frequent inspection regime and subsequent cleaning.

Checking the results of cleaning should be combined with checking the functions of the system after cleaning, and readjustments made where required.

In order to maintain ductwork hygiene, both the supply and re-circulated airstreams should be clean (see TR/19: *Guide to Good Practice* (BESA, 2013c)). Access must be available for cleaning to minimise the build up of microbial growth on ductwork, fan blades or coils (see CIBSE TM26: *Hygienic maintenance of office ventilation ductwork* (2000b)); the latter can result in loss of performance. There is also a need for regular inspections. To minimise pressure drops caused by filtration, the airflow entering a filter should be uniform, requiring the filter surface to be as large as possible. A manometer should be installed across each filter bank to ascertain when filters need changing and access doors should be provided for ease of filter replacement.

#### 2.7.2.5 Cleaning methods

There are several methods by which cleaning contractors can remove dust, debris and other surface contaminants:

- vacuum
- steam
- compressed air
- rotary brush.

Cleaning methods are more fully described in TR/19: *Guide to Good Practice* (BESA, 2013c) and BSRIA Technical Note

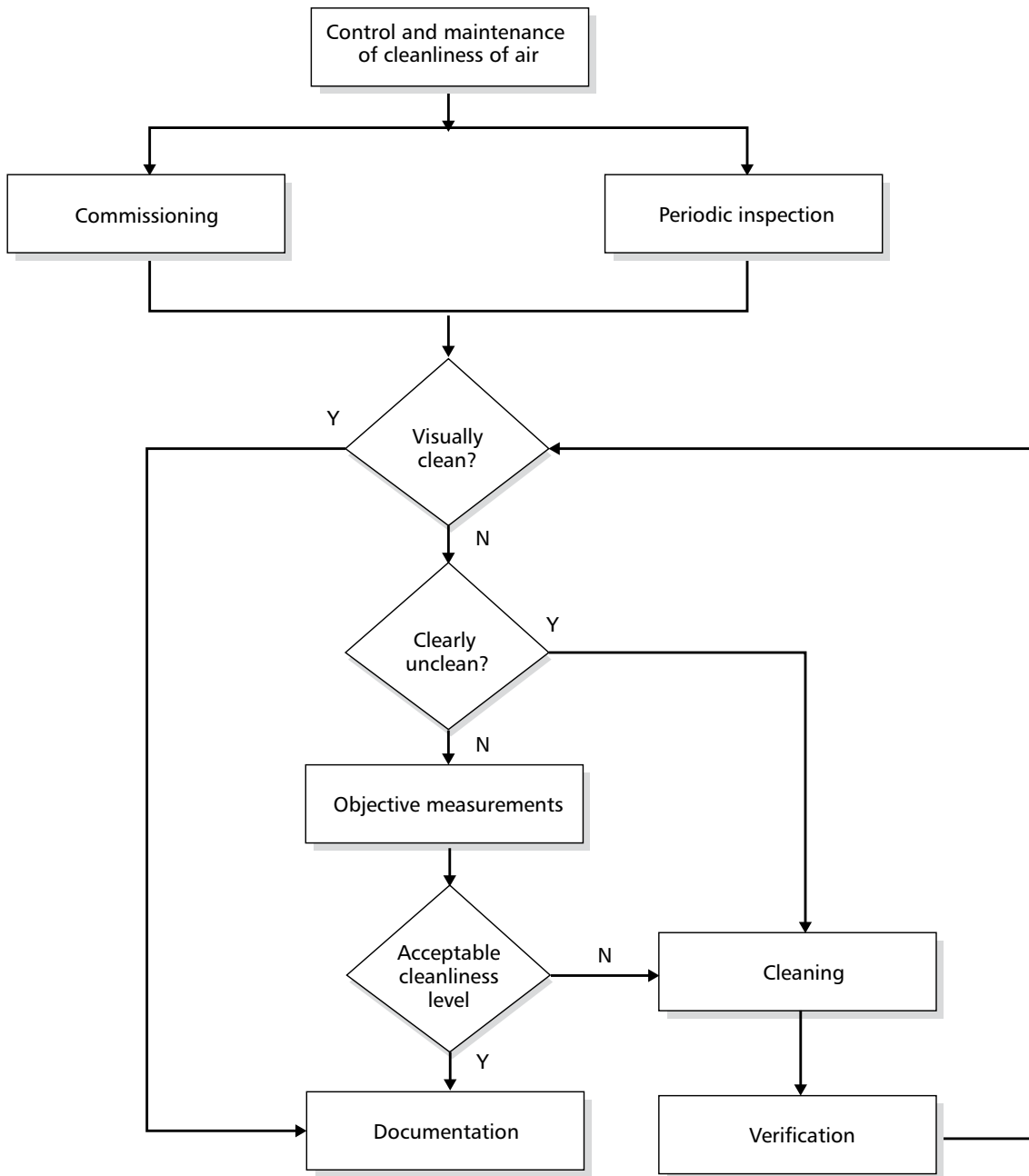

**Figure 2.64** Schematic flowchart for procedures to maintain cleanliness of ventilation system (reproduced from BS EN 15780: 2011: *Ventilation for buildings* (BSI, 2011b) by permission of the British Standards Institution)

TN 18/92: *Ventilation System Hygiene: A Review* (1996). Methods will vary according to the air distribution system. On the basis that the contaminants are dry, dry methods of cleaning are adequate for supply air and general extract systems. Wet methods are needed for air ducts in commercial kitchens and similar installations where extract air contains smoke, grease and other impurities.

The cleaning process involves loosening dirt adhering to ductwork surfaces and its subsequent removal. The loosening can be remotely by compressed air or rotary brushing equipment in conjunction with removal by industrial vacuum collector. Dust may alternatively be removed directly by a technician crawling along the ducts using a hand-held vacuum cleaner. When cleaning within ducts it is essential that sensor probes are withdrawn to prevent them from being damaged.

Dust resulting from cleaning, particularly that which may contain biologically active material, should be disposed of safely.

When cleaning is complete, the ductwork system may require rebalancing. Most cleaning contractors leave dampers and other control devices in their ‘as found’ positions. Based on system performance, the property operator will then need to decide whether rebalancing is required. It is recommended that a commissioning specialist be appointed to undertake this task.

## References

- Action Energy (1996) *Variable Flow Control* General Information Report GIR 41 (Garston: Action Energy)
- Action Energy (1997) *Energy-efficient Mechanical Ventilation Systems* Good Practice Guide GPG 257 (Garston: Action Energy)
- ACGIH (2013) *Industrial Ventilation: A Manual of Recommended Practice* (28th edn) (Lansing, MI: American Conference of Governmental Industrial Hygienists)
- AIVC (1990) *Fundamentals of the Multizone Air Flow Model: COMIS* AIVC TN 29 (Coventry: Air Infiltration and Ventilation Centre)
- AIVC (1994) *Air-to-air Recovery in Ventilation* AIVC TN 45 (Coventry: Air Infiltration and Ventilation Centre)
- AIVC (1996) *Guide to Ventilation* (Coventry: Air Infiltration and Ventilation Centre)
- Allard, R (2001) 'Get a whole-life' *Building* 266 (18) 69
- Andersson J, Boerstra A, Clements-Croome D, Fitzner K and Hanssen SO (2006) *Indoor Climate and Productivity in Offices: How to Integrate Productivity in Life-cycle Cost Analysis of Building Services* REHVA Technical Note 6 (Brussels: REHVA)
- ASFP (2000) *Fire Rated and Smoke Outlet Ductwork* ('The ASFP Blue Book') (Aldershot: Association for Specialist Fire Protection)
- ASFP (2010) *Fire Dampers (European Standards)* ('The ASFP Grey Book') (Aldershot: Association for Specialist Fire Protection)
- ASHRAE (2008) 'Chapter 8: Air-to-air energy recovery' in *ASHRAE Handbook: HVAC Systems and Equipment* (Atlanta, GA: ASHRAE)
- ASHRAE (2009) *ASHRAE Handbook: Fundamentals* (Atlanta, GA: ASHRAE)
- ASHRAE (2013) *Introduction to Building Information Modelling (BIM)* (Atlanta, GA: ASHRAE)
- ATTMA (2010) *Technical Standard L1 and L2: Measuring Air Permeability of Building Envelopes (L1A Dwellings and L2A Non Dwellings)* (Sheffield: Air Tightness Testing and Measurement Association)
- Awbi H (2003) *Ventilation of Buildings* (London: Spon Press)
- Baker N V and Steemers K *The LT Method 2.0: an energy design tool for non-domestic buildings* (Cambridge: Cambridge Architectural Research) (1994)
- BCO (2009) *BCO Guide to Specification* (London: British Council for Offices)
- Bennett KM (1996) *Air Filters* BSRIA Selection Guide SG7/91 (Bracknell: Building Services Research and Information Association)
- BESA (2005) *Specification for Kitchen Ventilation Systems* DW/172 (Penrith: Building Engineering Services Association)
- BESA (2010) *Guide to Good Practice for the Installation of Fire and Smoke Dampers* DW/145 (Penrith: Building Engineering Services Association)
- BESA (2012) *Standard Maintenance Specification for Building Services* SFG20 (Penrith: Building Engineering Services Association)
- BESA (2013a) *Specification for Sheet Metal Ductwork* DW/144 (Penrith: Building Engineering Services Association)
- BESA (2013b) *Guide to Good Practice: Ductwork Air Leakage Testing* DW/143 (Penrith: Building Engineering Services Association)
- BESA (2013c) *Guide to Good Practice: Internal Cleanliness of Ventilation Systems* TR/19 (Penrith: Building Engineering Services Association)
- BMI (1999) *BMI Index Special Report 281: Energy Benchmarking in the Retail Sector* (London: BMI Research)
- Bordass WT, Bromley AKR and Leaman AJ (1995) BRE Information Paper IP3/95: *Comfort, Control and Energy Efficiency in Offices* (Garston: Building Research Establishment)
- Bordass WT, Bunn R, Cohen R and Leaman AJ (1999) 'The Probe Project: technical lessons from PROBE 2' *Proc. CIBSE National Conference, Harrogate, October 1999*
- Bornehag CG, Sundell J, Hägerhed-Engman L and Sigsgaard T (2005) 'Association between ventilation rates in 390 Swedish homes and allergic symptoms in children' *Indoor Air* 15 (4) 275–280
- Braham D, Barnard N and Jaunzens D (2001) *Thermal Mass in Office Buildings* BRE Digest 454 (Garston: Building Research Establishment)
- BRE (1990) *Design Principles for Smoke Ventilation in Enclosed Shopping Centres* BRE Report BR 186 (Garston: Building Research Establishment)
- BRE (1994) *Continuous Mechanical Ventilation in Dwellings: Design, Installation and Operation* BRE Digest 398 (Garston: Building Research Establishment)
- BRE (1994) *Passive Stack Ventilation in Dwellings* BRE Information Paper IP 13/94 (Garston: Building Research Establishment)
- BRE (1998) *Trickle ventilators in offices* (Garston: Building Research Establishment)
- BRE (1999a) *Design Methodologies for Smoke and Heat Exhaust Ventilation within Atria* BRE Report BR 368 (Garston: Building Research Establishment)
- BRE (1999b) *Natural Ventilation in Atria for Environment and Smoke Control: An Introductory Guide* BRE Report BR 375 (Garston: Building Research Establishment)
- BRE (1999c) *Air distribution in naturally ventilated offices* (Garston: Building Research Establishment)
- BRE (2002) *Thermal Insulation: Avoiding Risks* BRE Report BR 262 (Garston: Building Research Establishment)
- BRE (2005) *Smoke Ventilation of Common Access Areas of Flats and Maisonettes (BD2410): Final Factual Report* BRE Project Report 213179 (Garston: Building Research Establishment)
- BREEAM (2014) *Environmental Assessment Method 2011 Scheme* (Garston: Building Research Establishment)
- BSI (1987a) BS 476-20: 1987: *Fire tests on building materials and structures. Method for determination of the fire resistance of elements of construction (general principles)* (London: British Standards Institution)
- BSI (1987b) BS 476-22: 1987: *Fire tests on building materials and structures. Method for determination of the fire resistance of non-loadbearing elements of construction* (London: British Standards Institution)
- BSI (1987c) BS 476-24: 1987, ISO 6944: 1985: *Fire tests on building materials and structures. Method for determination of the fire resistance of ventilation ducts* (London: British Standards Institution)
- BSI (1991) BS 5925: 1991: *Code of practice for ventilation principles and designing for natural ventilation* (London: British Standards Institution)
- BSI (1997a) BS 8313: 1997: *Code of practice for accommodation of building services in ducts* (London: British Standards Institution)

- BS EN ISO 12241: 1998: *Thermal insulation for building equipment and industrial installations. Calculation rules* (London: British Standards Institution) [Withdrawn]
- BSI (1999–2013) BS EN ISO 14644: *Cleanrooms and associated controlled environments* (Parts 1–12) (London: British Standards Institution)
- BSI (2000) BS EN 12207: 2000: *Windows and doors. Air permeability. Classification* (London: British Standards Institution)
- BSI (2003a) BS EN 12237: 2003: *Ventilation for buildings. Ductwork. Strength and leakage of circular sheet metal ducts* (London: British Standards Institution)
- BSI (2003b) BS EN 12101-2: 2003: *Smoke and heat control systems. Specification for natural smoke and heat exhaust ventilators* (London: British Standards Institution)
- BSI (2003c) BS EN 12792: 2003: *Ventilation for buildings. Symbols, terminology and graphical symbols* (London: British Standards Institution)
- BSI (2004) BS EN 1366-8: 2004: *Fire resistance tests for service installations. Smoke extraction ducts* (London: British Standards Institution)
- BSI (2005a) BS EN ISO 7730: 2005: *Ergonomics of the thermal environment. Analytical determination and interpretation of thermal comfort using calculation of the PMV and PPD indices and local thermal comfort criteria* (London: British Standards Institution)
- BSI (2005b) BS EN 13501-3: 2005 + A1: 2009: *Fire classification of construction products and building elements. Classification using data from fire resistance tests on products and elements used in building service installations: fire resisting ducts and fire dampers* (London: British Standards Institution)
- BSI (2005c) BS EN 1991-1-4: 2005 + A1: 2010: *Eurocode 1. Actions on structures. General actions. Wind actions* (London: British Standards Institution)
- BSI (2006a) BS EN 1507: 2006: *Ventilation for buildings. Sheet metal air ducts with rectangular section. Requirements for strength and leakage* (London: British Standards Institution)
- BSI (2006b) BS EN 12097: 2006: *Ventilation for buildings. Requirements for ductwork components to facilitate maintenance of ductwork systems* (London: British Standards Institution)
- BSI (2006c) BS EN 13053: 2006 + A1: 2011: *Ventilation for buildings. Air handling units. Rating and performance for units, components and sections* (London: British Standards Institution)
- BSI (2007a) BS EN 13779: 2007: *Ventilation for non-residential buildings. Performance requirements for ventilation and room-conditioning systems* (London: British Standards Institution)
- BSI (2007b) BS EN 15251: 2007: *Indoor environmental input parameters for design and assessment of energy performance of buildings addressing indoor air quality, thermal environment, lighting and acoustics* (London: British Standards Institution)
- BSI (2007c) BS EN 13501-4: 2007 + A1: 2009: *Fire classification of construction products and building elements. Classification using data from fire resistance tests on components of smoke control systems* (London: British Standards Institution)
- BSI (2008a) BS 9999: 2008: *Code of practice for fire safety in the design, management and use of buildings* (London: British Standards Institution)
- BSI (2008b) BS EN 1366-9: 2008: *Fire resistance tests for service installations. Single compartment smoke extraction ducts* (London: British Standards Institution)
- BSI (2008c) BS EN ISO 5801: 2008, BS 848-1: 2007: *Industrial fans. Performance testing using standardized airways* (London: British Standards Institution)
- BSI (2009a) BS EN 1822-5: 2009: *High efficiency air filters (EPA, HEPA and ULPA). Determining the efficiency of filter elements* (London: British Standards Institution)
- BSI (2009b) BS 5422: 2009: *Method for specifying thermal insulating materials for pipes, tanks, vessels, ductwork and equipment operating within the temperature range  $-40^{\circ}\text{C}$  to  $+700^{\circ}\text{C}$*  (London: British Standards Institution)
- BSI (2010a) BS 5864: 2010: *Installation and maintenance of gas-fired ducted air heaters of rated heat input not exceeding 70 kW net (2nd and 3rd family gases). Specification* (London: British Standards Institution)
- BSI (2010b) BS EN 15650: 2010: *Ventilation for buildings. Fire dampers* (London: British Standards Institution)
- BSI (2010c) BS EN ISO 13349: 2010: *Fans. Vocabulary and definitions of categories* (London: British Standards Institution)
- BSI (2011a) BS 5250: 2011: *Code of practice for control of condensation in buildings* (London: British Standards Institution)
- BSI (2011b) BS EN 15780: 2011: *Ventilation for buildings. Ductwork. Cleanliness of ventilation systems* (London: British Standards Institution)
- BSI (2012a) BS EN 779: 2012: *Particulate air filters for general ventilation. Determination of the filtration performance* (London: British Standards Institution)
- BSI (2012b) BS 5970: 2012: *Thermal insulation of pipework, ductwork, associated equipment and other industrial installations in the temperature range of  $-100^{\circ}\text{C}$  to  $+870^{\circ}\text{C}$ . Code of practice* (London: British Standards Institution)
- BSI (2012c) BS EN 1363-1: 2012: *Fire resistance tests. General requirements* (London: British Standards Institution)
- BSI (2014a) BS EN 1366-1: 2014: *Fire resistance tests for service installations. Ventilation ducts* (London: British Standards Institution)
- BSI (2014b) BS 8233: 2014: *Guidance on sound insulation and noise reduction for buildings* (London: British Standards Institution)
- BSI (2015) BS 6375-1: 2015: *Performance of windows and doors. Classification for weathertightness and guidance on selection and specification* (London: British Standards Institution)
- BSI (2015b) BS EN 12101-3: 2015: *Smoke and heat control systems. Specification for powered smoke and heat control ventilators (Fans)* (London: British Standards Institution)
- BSI (2015a) BS EN 1366-2: 2015: *Fire resistance tests for service installations. Fire dampers* (London: British Standards Institution)
- BSI (2015b) BS EN 12101-3: 2015: *Smoke and heat control systems. Specification for powered smoke and heat control ventilators (Fans)* (London: British Standards Institution)
- BSI (2015c) BS EN ISO 12759: 2015: *Fans. Efficiency classification for fans* (London: British Standards Institution)
- BSRIA (1992) *Spatial Allowances for Building Services Distribution Systems* BSRIA Technical Note TN 10/92 (Bracknell: BSRIA)
- BSRIA (1996) *Ventilation System Hygiene: A Review* Technical Note TN 18/92 (Bracknell: BSRIA)
- BSRIA (2000) *Location of Fresh Air Intakes* BSRIA TN 12/2000 (Bracknell: BSRIA)

- BSRIA (2001) *Commissioning Air Systems* BSRIA Application Guide AG 3/89.3 (Bracknell: BSRIA)
- BSRIA (2008) *Whole-Life Costing Analysis* Guide BSRIA BG5/2008 (Bracknell: BSRIA)
- BSRIA (2009a) *Building Services Job Book: A Project Framework for Engineering Services* (Bracknell: BSRIA)
- BSRIA (2009b) *Heat Recovery Systems* BSRIA HRS 1/2009 (Bracknell: BSRIA)
- BSRIA (2011) *Rules of Thumb* (5th ed.) (Bracknell: BSRIA)
- CABE (2009) *Successful School Design* (London: CABE)
- Carbon Trust (2006) *Heating, Ventilation and Air Conditioning (HVAC), Saving Energy Without Compromising Comfort* Report CTV003 (London: Carbon Trust)
- Carbon Trust (2007) *Air conditioning: maximising comfort, minimising energy* Consumption Report CTGOO5 (London: Carbon Trust)
- Carbon Trust (2012) *The Enhanced Capital Allowance Scheme for Energy-saving Technologies ECA272* (London: Carbon Trust)
- Charlesworth PS (1988) *Air Exchange Rate and Airtightness Measurement Techniques: An Application Guide* (Coventry: Air Infiltration and Ventilation Centre)
- CIBSE (1999) *Minimising pollution at air intakes* CIBSE TM21 (London: Chartered Institution of Building Services Engineers)
- CIBSE (2000a) *Mixed mode ventilation* CIBSE AM13 (London: Chartered Institution of Building Services Engineers)
- CIBSE (2000b) *Hygienic maintenance of office ventilation ductwork* CIBSE TM26 (London: Chartered Institution of Building Services Engineers)
- CIBSE (2000c) *Testing buildings for air leakage* CIBSE TM23 (London: Chartered Institution of Building Services Engineers)
- CIBSE (2002) *Improved life cycle performance of mechanical ventilation systems* CIBSE TM30 (London: Chartered Institution of Building Services Engineers)
- CIBSE (2003) *Commissioning management* CIBSE Commissioning Code M (London: Chartered Institution of Building Services Engineers)
- CIBSE (2005) *Natural ventilation in non-domestic buildings* CIBSE AM10:(London: Chartered Institution of Building Services Engineers)
- CIBSE (2006a) *Health issues in building services* CIBSE TM40 (London: Chartered Institution of Building Services Engineers)
- CIBSE (2006b) *Air Distribution Systems* Commissioning Code A (London: Chartered Institution of Building Services Engineers)
- CIBSE (2006c) *Building log book toolkit* CIBSE TM31 (London: Chartered Institution of Building Services Engineers)
- CIBSE (2007) *Reference data* CIBSE Guide C (London: Chartered Institution of Building Services Engineers)
- CIBSE (2010) *Fire engineering* CIBSE Guide E (London: Chartered Institution of Building Services Engineers)
- CIBSE (2011) *Indoor air quality and ventilation* CIBSE KS17 (London: Chartered Institution of Building Services Engineers)
- CIBSE (2012) *Energy efficiency in buildings* CIBSE Guide F (London: Chartered Institution of Building Services Engineers)
- CIBSE (2014) *Public health and plumbing engineering* CIBSE Guide G (London: Chartered Institution of Building Services Engineers)
- CIBSE (2015a) *Environmental design* CIBSE Guide A (London: Chartered Institution of Building Services Engineers)
- CIBSE (2016a) *Refrigeration and air conditioning* CIBSE Guide B3 (London: Chartered Institution of Building Services Engineers)
- CIBSE (2016b) *Applications and activities* CIBSE Guide B0 (London: Chartered Institution of Building Services Engineers)
- CIBSE (2016c) *Building performance modelling* CIBSE AM11 (London: Chartered Institution of Building Services Engineers)
- CIBSE (2016c) *Heating* CIBSE Guide B1 (London: Chartered Institution of Building Services Engineers)
- CIBSE (2016d) *Noise and vibration control for building services systems* CIBSE Guide B4 (London: Chartered Institution of Building Services Engineers)
- DEFRA (2007) *Air Quality Strategy for England, Scotland, Wales and Northern Ireland: Working Together for Clean Air* CM 4548 (London: TSO) (available at [https://www.gov.uk/government/uploads/system/uploads/attachment\\_data/file/69336/pb12654-air-quality-strategy-vol1-070712.pdf](https://www.gov.uk/government/uploads/system/uploads/attachment_data/file/69336/pb12654-air-quality-strategy-vol1-070712.pdf)) (accessed November 2015)
- DEO (1996) *Space requirements for plant access, operation and maintenance* Design and Maintenance Guide 08 (London: Ministry of Defence/Defence Estates Organisation) (available at [http://webarchive.nationalarchives.gov.uk/+http://www.defence-estates.mod.uk/publications/dmg/dmg\\_08.pdf](http://webarchive.nationalarchives.gov.uk/+http://www.defence-estates.mod.uk/publications/dmg/dmg_08.pdf)) (accessed November 2015)
- Dietz RN and Cote EA (1982) 'Air infiltration measurements in a home using a convenient perfluorocarbon tracer technique' *Environment International* 8 (1-6) 419-433
- EC (1980) 'Council Directive 80/779/EEC of 15 July 1980 on air quality limit values and guide values for sulphur dioxide and suspended particulates' *Official Journal L229* (30.8.1980) 30-48 (available at <http://eur-lex.europa.eu/legal-content/EN/TXT/?uri=celex:31980L0779>) (accessed November 2015)
- EC (1992) 'Council Directive 92/75/EEC of 22 September 1992 on the indication by labelling and standard product information of the consumption of energy and other resources by household appliance' *Official Journal L297* (13.10.1992) 16-19 (available at <http://eur-lex.europa.eu/legal-content/en/ALL/?uri=CELEX:31992L0075>) (accessed November 2015)
- EC (2002) 'Directive 2002/91/EC of the European Parliament and of the Council of 16 December 2002 on the energy performance of buildings' *Official Journal L1* (4.1.2003) 65-71 (available at <http://eur-lex.europa.eu/legal-content/EN/TXT/?uri=celex:32002L0091>) (accessed November 2015)
- EC (2005) 'Directive 2005/32/EC of the European Parliament and of the Council of 6 July 2005 establishing a framework for the setting of ecodesign requirements for energy-using products and amending Council Directive 92/42/EEC and Directives 96/57/EC and 2000/55/EC of the European Parliament and of the Council' *Official Journal L191* (22.7.2005) 29-58 (available at <http://eur-lex.europa.eu/LexUriServ/LexUriServ.do?uri=OJ:L:2005:191:0029:0058:en:PDF>) (accessed November 2015)
- EC (2008) 'Directive 2008/50/EC of the European Parliament and of the Council of 21 May 2008 on ambient air quality and cleaner air for Europe' *Official Journal L152* (11.6.2008) 1-44 (available at <http://eur-lex.europa.eu/legal-content/en/ALL/?uri=CELEX:32008L0050>) (accessed November 2015)
- EC (2009) 'Directive 2009/125/EC of the European Parliament and of the Council of 21 October 2009 establishing a framework for the setting of ecodesign requirements for energy-using products' *Official Journal L285*

- (31.10.2009) 10–35 (available at <http://eur-lex.europa.eu/legal-content/EN/ALL/?uri=CELEX:32009L0125>) (accessed November 2015)
- EFA (2004) *Acoustic design of schools — performance standards* Building Bulletin BB83 (London: Education Funding Agency) (available at <https://www.gov.uk/government/publications/bb93-acoustic-design-of-schools-performance-standards>) (accessed November 2015)
- Environmental Protection UK (2010) *Development Control: Planning For Air Quality (2010 Update)* (Brighton: Environmental Protection UK) (available at <http://www.environmental-protection.org.uk/wp-content/uploads/2013/07/EPUK-Development-Control-Planning-for-Air-Quality-2010.pdf>) (accessed November 2015)
- EU (2010) ‘Directive 2010/31/EU of the European Parliament and of the Council of 19 May 2010 on the energy performance of buildings (Recast)’ *Official Journal of the European Union* L153 (18.6.2010) 13–35 (available at <http://eur-lex.europa.eu/LexUriServ/LexUriServ.do?uri=OJ:L:2010:153:0013:0035:EN:PDF>) (accessed November 2015)
- Eurovent (1999) *Recommendation concerning indoor air quality REC 08* (Vienna: Eurovent) (available at [http://www.eurovent-association.eu/fic\\_bdd/pdf\\_en\\_fichier/REC08\\_12772792070.pdf](http://www.eurovent-association.eu/fic_bdd/pdf_en_fichier/REC08_12772792070.pdf)) (accessed November 2015)
- Evans R, Haste N, Jones A and Haryott R (1998) *The Long Term Costs of Owning and Using Buildings* (London: Royal Academy of Engineering)
- Gilbert A (1999) *Laboratory testing of air cleaners* BSRIA Specification SS 22/99: (Bracknell: BSRIA)
- Hamilton G (1986) *Selection of air-to-air heat recovery systems* BSRIA Technical Note TN11/86 (Bracknell: BSRIA)
- Hayden GW and Parsloe CJ (1996) *Value Engineering of Building Services* BSRIA Applications Guide AG15/96 (Bracknell: BSRIA)
- HEVAC (2010) *Design of Smoke Ventilation Systems for Loading Bays and Coach Parks* (Marlow: HEVAC Association)
- HEVAC (2012) *Guidance on Smoke Control to Common Escape Routes in Apartment Buildings (Flats and Maisonettes)* (Marlow: HEVAC Association)
- HEVAC (2015) *Guide to Air Distribution Technology for the Internal Environment* (Marlow: HEVAC Association)
- Hittle DC, Dolan WH, Leverenz DJ and Rundus R (1982) ‘Theory meets practice in a full-scale HVAC laboratory’ *ASHRAE Journal* 24 (11) 36
- HMRC (2012) *A General Guide to Climate Change Levy Excise Notice CCL1* (London: HM Revenue & Customs) (available at <https://www.gov.uk/government/publications/excise-notice-ccl1-a-general-guide-to-climate-change-levy/excise-notice-ccl1-a-general-guide-to-climate-change-levy>) (accessed November 2015)
- HMSO (1974) *Health and Safety at Work, etc. Act 1974* Elizabeth II Chapter 37 (London: HMSO) (available at <http://www.legislation.gov.uk/ukpga/1974/37>) (accessed November 2015)
- HMSO (1990) *Environmental Protection Act 1990* (London: HMSO) (available at <http://www.legislation.gov.uk/ukpga/1990/43>) (accessed November 2015)
- HMSO (1992) *The Workplace (Health, Safety and Welfare) Regulations 1992* Statutory Instrument 1992 No. 3004 (London: HMSO) (available at <http://www.legislation.gov.uk/uksi/1992/3004>) (accessed November 2015)
- HSE (1994) *Workplace Health, Safety and Welfare — Workplace (Health, Safety and Welfare) Regulations 1992* Approved Code of Practice and guidance L24 (Sudbury: HSE Books)
- HSE (1998) *The maintenance, examination and testing of local exhaust ventilation* HSG54 (Sudbury: HSE Books)
- HSE (2011) *EH40/2005 Workplace exposure limits* (2nd edn) (Sudbury: HSE Books) (available at <http://www.hse.gov.uk/pubns/books/eh40.htm>) (accessed November 2015)
- HVCA (2000) *Standard for Kitchen Ventilation Systems* DW/171 (London: HVCA)
- Hwang CL, Tillman FA and Lin MJ (1984) ‘Optimal design of an air jet for spot cooling’ *ASHRAE Transactions* 90 (1B) 476
- IEC (2014) IEC 60034-30-1: 2014: *Rotating electrical machines. Part 30-1: Efficiency classes of line operated AC motors (IE code)* (Geneva: International Electrotechnical Commission (IEC))
- Iqbal MA, Willson TK and Thomas RJ (1977) *Control of Noise in Ventilation Systems* (London: E & FN Spon)
- Jackman PJ (1990) *Displacement Ventilation* BSRIA TM2/90 (Bracknell: BSRIA)
- Jaggs M and Scivyer C (2011) *Airtightness in Commercial and Public Buildings* BRE Report FB35 (Bracknell: BRE Press)
- Kukadia V and Hall D (2011) *Ventilation for Healthy Buildings: Reducing the Impact of Urban Air Pollution* BRE Report FB30 (Bracknell: BRE Press)
- Li Y (2002) ‘Spurious numerical solutions in coupled natural ventilation and thermal analyses’ *International Journal of Ventilation* 1 (1) 1–12
- Liddament M (1996) *AIVC Guide to Energy Efficient Ventilation* (Coventry: Air Infiltration and Ventilation Centre)
- NBS (2013a) *Conservation of fuel and power* Building Regulations Approved Document L (4 Parts) (2013 edn) (Newcastle upon Tyne: NBS) (available at <http://www.planningportal.gov.uk/buildingregulationsapproveddocuments/partl/approved>) (accessed November 2015)
- NBS (2013b) *Ventilation* Building Regulations Approved Document F (2010 edn incorporating 2010 and 2013 amendments) (Newcastle upon Tyne: NBS) (available at <http://www.planningportal.gov.uk/buildingregulations/approveddocuments/partf>) (accessed November 2015)
- NBS (2013c) *Site preparation and resistance to contaminants and moisture* Building Regulations Approved Document C (2004 edn incorporating 2010 and 2013 amendments) (Newcastle upon Tyne: NBS) (available at <http://www.planningportal.gov.uk/buildingregulations/approveddocuments/partc/documentc>) (accessed November 2015)
- NBS (2013d) *Domestic Building Services Compliance Guide* (2013 edn) (Newcastle upon Tyne: NBS) (available at <http://www.planningportal.gov.uk/buildingregulations/approveddocuments/partl/compliance>) (accessed November 2015)
- NBS (2013e) *Non-Domestic Building Services Compliance Guide* (Newcastle upon Tyne: NBS) (available at <http://www.planningportal.gov.uk/buildingregulations/approveddocuments/partl/compliance>) (accessed November 2015)
- NBS (2013f) *Combustion appliances and fuel storage systems* Building Regulations Approved Document J (2010 edn incorporating 2010 and 2013 amendments) (Newcastle upon Tyne: NBS) (available at <http://www.planningportal.gov.uk/buildingregulations/approveddocuments/partj/approved>) (accessed November 2015)
- NBS (2013g) *Fire safety* Building Regulations Approved Document B (2 volumes) (2006 edn incorporating 2010 and 2013 amendments) (Newcastle upon Tyne: NBS) (available at <http://www.planningportal.gov.uk/buildingregulations/approveddocuments/partb/bcapproveddocumentsb>) (accessed November 2015)
- NES (1996) *National Engineering Specification Y42: Air Filtration* (Milton Keynes: Amtech)

- NHS (2009) *Saving Carbon Improving Health: The NHS Carbon Reduction Strategy* (Cambridge: National Health Service Sustainable Development Unit) (available at <http://www.sduhealth.org.uk/policy-strategy/engagement-resources/nhs-carbon-reduction-strategy-2009.aspx>) (accessed November 2015)
- NIST (2010) *CONTAM User Guide* [online] (Gaithersburg, MD: National Institute of Standards and Technology) (<http://www.bfirl.nist.gov/IAQanalysis/CONTAM/userguide.htm>) (accessed November 2015)
- Orme M, Liddament MW and Wilson A (1994) *An Analysis and Summary of the AIVC's Numerical Database* AIVC Technical Note 44 (Coventry: Air Infiltration and Ventilation Centre)
- Oughton DL and Wilson A (2015) *Faber and Kell's Heating and Air Conditioning of Buildings* (11th edn) (London: Routledge)
- Phaff H (1988) 'Measurement of low air flow rates using a simple pressure compensating meter' *Air Infiltration Review* 9 (4)
- Pike PG (1996) *Air Filters* BSRIA Application Guide AG8/97 (Bracknell: Building Services Research and Information Association)
- Pitts AC and Georgiadis S (1994) 'Ventilation air flow through window openings in combination with shading devices' *Proc. 15th AIVC Conference, Buxton, 1994*
- REHVA (2003) *Guide to Displacement Ventilation in Non-industrial Premises* (Brussels: REHVA)
- Roulet (1991) *Measurement Techniques* AIVC Tech Note (Coventry: Air Infiltration and Ventilation Centre)
- Sandberg M and Blomqvist C (1989) 'Displacement Ventilation Systems in Office Rooms.' *ASHRAE Trans.* 95(2) (Atlanta, GA: ASHRAE)
- Saxon R (1986) *Atrium Buildings: Development and Design* (London: Longman)
- Scottish Government (2015) *Technical Handbook* (2 volumes) (Edinburgh: Scottish Government Building Standards Division)
- Sherman MH and Grimsrud DT (1980) 'Measurement of infiltration using fan and pressurisation data' *Proc. AIC Conference Instrumentation and measurement techniques, 1980*
- SLL (2015) *Daylighting: a guide for designers* SLL LG10 (London: Society of Light and Lighting)
- SMACNA (2006) *HVAC Systems Duct Design* (4th ed.) (Virginia: Sheet Metal and Air Conditioning Contractors' National Association)
- Sodec F (1984) *Air Distribution Systems* Report 3554E (Aachen: Krantz GmbH)
- Stewart LJ (1985) *Design Guidelines for Exhaust Hoods* BSRIA Technical Note TN3/85 (Bracknell: BSRIA)
- Thomas R (ed.) (2005) *Environmental Design: An Introduction for Architects and Engineers* (3rd edn) (London: Taylor & Francis)
- TSO (1999) The Town and Country Planning (Environmental Impact Assessment) (England and Wales) Regulations 1999 Statutory Instrument 1999 No. 293 (as amended) (London: The Stationery Office (TSO)) (available at <http://www.legislation.gov.uk/uksi/1999/293>) (accessed November 2015)
- TSO (2005) The Regulatory Reform (Fire Safety) Order 2005 (RRFSO) Statutory Instrument 2005 No. 1541 (London: The Stationery Office (TSO)) (available at <http://www.legislation.gov.uk/uksi/2005/1541>) (accessed November 2015)
- TSO (2010) The Building Regulations 2010 Statutory Instruments No. 2214 2010 (London: The Stationery Office) (available at <http://www.legislation.gov.uk/uksi/2010/2214>) (accessed November 2015)
- TSO (2015) The Construction (Design and Management) Regulations 2015 Statutory Instruments No. 51 2015 (London: The Stationery Office (TSO)) (available at <http://www.legislation.gov.uk/uksi/2015/51>) (accessed November 2015)
- Upton S and Kukadia V (2011) *Ventilation rate measurement: New tracer gases and techniques for healthy indoor environments* BRE Information Paper IP 13/11 (Garston: Building Research Establishment)
- White MK and Stephen R (1999) *Ventilators: Ventilation and Acoustic Effectiveness* BRE Information Paper IP4/99 (Garston: BRE)
- Willis S, Fordham M and Bordass W (1995) *Avoiding or Minimising the Use of Air Conditioning* General Information Report GIR 31 (Garston: Action Energy)

## Appendix 2.A1: Recommended sizes for ductwork

Table 2.A1.1 Recommended sizes for rectangular ductwork, including equivalent diameter, hydraulic diameter, cross sectional area and perimeter (based on BS EN 1505)

Longer side / mm	Parameter*	Shorter side / mm										Parameter*					
		100	150	200	250	300	400	500	600	800	1000		1200				
150	$d_c$	134	165													$d_c$	
	$P$	0.5	0.6														$P$
	$d_h$	120.00	141.55	180.82													$d_h$
	$A$	0.015	0.0225	0.03													$A$
200	$d_c$	154	190	220													$d_c$
	$P$	0.6	0.7	0.8													$P$
	$d_h$	133.33	171.43	200.00													$d_h$
	$A$	0.02	0.03	0.04	0.05												$A$
250	$d_c$	171	212	246	275												$d_c$
	$P$	0.7	0.8	0.9	1.0												$P$
	$d_h$	142.86	187.50	222.22	250.00												$d_h$
	$A$	0.025	0.0375	0.05	0.0625	0.075											$A$
300	$d_c$	185	231	269	301	330											$d_c$
	$P$	0.8	0.9	1.0	1.1	1.2											$P$
	$d_h$	150.00	200.00	240.00	272.73	300.00											$d_h$
	$A$	0.03	0.045	0.06	0.075	0.09	0.12										$A$
400	$d_c$	211	264	308	346	387	441										$d_c$
	$P$	1.0	1.1	1.2	1.3	1.4	1.6										$P$
	$d_h$	160.00	218.18	266.67	307.69	342.86	400.00										$d_h$
	$A$	0.04	0.06	0.08	0.1	0.12	0.16	0.2									$A$
500	$d_c$	291	341	371	385	424	492	551									$d_c$
	$P$	1.3	1.4	1.5	1.6	1.6	1.8	2.0									$P$
	$d_h$	230.77	285.71	333.33	333.33	375.00	444.44	500.00									$d_h$
	$A$	0.075	0.1	0.125	0.15	0.15	0.2	0.25	0.3								$A$
600	$d_c$	316	371	419	419	462	537	603	661								$d_c$
	$P$	1.5	1.6	1.7	1.8	1.8	2.0	2.2	2.4								$P$
	$d_h$	240.00	300.00	352.94	352.94	400.00	480.00	545.45	600.00								$d_h$
	$A$		0.12	0.15	0.18	0.18	0.24	0.3	0.36	0.48							$A$
800	$d_c$	421	477	527	477	527	616	693	761	881							$d_c$
	$P$	2.0	2.1	2.2	2.1	2.2	2.4	2.6	2.8	3.2							$P$
	$d_h$	320.00	380.95	436.36	380.95	436.36	533.33	615.38	600.00	800.00							$d_h$
	$A$		0.2	0.24	0.2	0.24	0.32	0.4	0.48	0.64							$A$
1000	$d_c$	527	583	632	527	583	683	770	848	984	1101						$d_c$
	$P$	2.5	2.6	2.6	2.5	2.6	2.8	3.0	3.2	3.6	4.0						$P$
	$d_h$	400.00	461.54	480.00	400.00	461.54	571.43	666.67	750.00	888.89	1000.00						$d_h$
	$A$	0.25	0.3	0.3	0.25	0.3	0.4	0.5	0.6	0.8	1.0	1.2					$A$
1200	$d_c$	632	741	837	632	741	837	837	924	1075	1205	1322					$d_c$
	$P$	3.0	3.2	3.4	3.0	3.2	3.4	3.4	3.6	4.0	4.4	4.8					$P$
	$d_h$	480.00	600.00	705.88	480.00	600.00	705.88	800.00	800.00	960.00	1090.91	1200.00					$d_h$
	$A$	0.36	0.48	0.6	0.36	0.48	0.6	0.72	0.96	1.2	1.2	1.44					$A$

\*  $d_c$  = equivalent diameter / mm;  $P$  = perimeter / m;  $d_h$  = hydraulic diameter / mm;  $A$  = cross sectional area / m<sup>2</sup>

Table continues

**Table 2A1.1** Recommended sizes for rectangular ductwork, including equivalent diameter, hydraulic diameter, cross sectional area and perimeter (based on BS EN 1505(A1.1)) — *continued*

Longer side / mm	Shorter side / mm										Parameter*	
	100	150	200	250	300	400	500	600	800	1000		1200
1400	$d_e$	794	898	992	1118	1231	1385	1523	1612	1799	1927	$d_e$
	$P$	3.6	3.8	4.0	4.4	4.8	5.2	5.6	6.0	6.4	6.8	$P$
	$d_h$	622.22	736.84	840.00	1018.18	1166.67	1292.31	1440.00	1523	1695	1848	$d_h$
	$A$	0.56	0.7	0.84	1.112	1.44	1.92	2.56	3.36	4.32	5.44	$A$
1600	$d_e$	843	954	1054	1231	1385	1523	1612	1799	1927	$d_e$	
	$P$	4.0	4.2	4.4	4.8	5.2	5.6	6.0	6.4	6.8	$P$	
	$d_h$	640.00	761.90	872.73	1066.67	1230.77	1371.43	1523	1695	1848	$d_h$	
	$A$	0.8	0.96	1.08	1.44	1.8	2.16	2.56	3.36	4.32	5.44	$A$
1800	$d_e$	1006	1112	1231	1385	1523	1612	1799	1927	$d_e$		
	$P$	4.6	4.8	5.2	5.6	6.0	6.4	6.8	7.2	7.6	$P$	
	$d_h$	782.61	900.00	1107.69	1285.71	1440.00	1523	1695	1848	1992	$d_h$	
	$A$	0.9	1.08	1.44	1.8	2.16	2.56	3.36	4.32	5.44	$A$	
2000	$d_e$	1053	1166	1231	1385	1523	1612	1799	1927	$d_e$		
	$P$	5.0	5.2	5.6	6.0	6.4	6.8	7.2	7.6	8.0	$P$	
	$d_h$	800.00	923.08	1142.86	1333.33	1500.00	1523	1695	1848	1992	$d_h$	
	$A$	1.0	1.2	1.6	2.0	2.4	2.56	3.36	4.32	5.44	$A$	

\*  $d_e$  = equivalent diameter / mm;  $P$  = perimeter / m;  $d_h$  = hydraulic diameter / mm;  $A$  = cross sectional area / m<sup>2</sup>**Table 2.A1.2** Recommended sizes for circular ducting (based on BS EN 1506)

Diameter, $d$ / mm	Perimeter, $P$ / m	Hydraulic diameter, $d_h$ / mm	Cross sectional area, $A$ / m <sup>2</sup>
63	0.198	63	0.004
80	0.251	80	0.006
100	0.314	100	0.010
125	0.393	125	0.016
150	0.470	150	0.023
160	0.502	160	0.026
200	0.628	200	0.040
250	0.785	250	0.063
315	0.990	315	0.099
355	1.115	355	0.126
400	1.257	400	0.160
450	1.413	450	0.203
500	1.571	500	0.250
560	1.760	560	0.314
630	1.979	630	0.397
710	2.229	710	0.504
800	2.512	800	0.640
900	2.826	900	0.810
1000	3.142	1000	1.000
1120	3.517	1120	1.254
1250	3.927	1250	1.563

DW/144 provides detailed guidance on duct sizing and should be referred to. The revised DW/144 (2013) includes provision for reducing the thickness of the sheet metal used in some sizes of ductwork and supersedes previous guidance.

## References

BESA (2013) *Specification for Sheet Metal Ductwork DW/144* (Penrith: BESA)

BSI (1998) BS EN 1505: 1998 *Ventilation for buildings. Sheet metal air ducts and fittings with rectangular cross-section. Dimensions* (London: British Standards Institution)

BSI (2007) BS EN 1506 *Ventilation for buildings. Sheet metal air ducts and fittings with circular cross section. Dimensions* (London: British Standards Institution)

## Appendix 2.A2: Space allowances

### 2.A2.1 Space allowances for ductwork

Figure 2.A2.1 shows the recommended space allowances for rectangular, circular and flat oval ductwork (BSRIA, 1992). Figure 2.A2.2 shows recommended space allowances for vertical risers, both insulated and uninsulated (DEO, 1996). Access to ducts is governed by the space required to install and insulate the ductwork and this is determined by the clearance from firm objects, the jointing method, and whether or not the ducts are to be insulated after installation. See BS 8313<sup>(2.A2.3)</sup> for details.

Duct clearances can be reduced with care, providing correct jointing, insulation and maintenance of vapour barriers is achieved. Consideration should also be given to how the ductwork will be tested and, eventually, replaced. See also BSRIA Technical Note TN10/92: *Space allowances for building services distribution systems* (BSRIA, 1992).

### 2.A2.2 Ductwork access: common problems

#### 2.A2.2.1 Fire dampers

Access to fire dampers must not be obstructed by other services. Clear access must be ensured for inspection and testing. Figure 2.A2.3 illustrates two common problems.

#### 2.A2.2.2 Ceiling-mounted terminal units

A typical installation is shown in Figure 2.A2.4. The ceiling grid immediately beneath the terminal unit should be

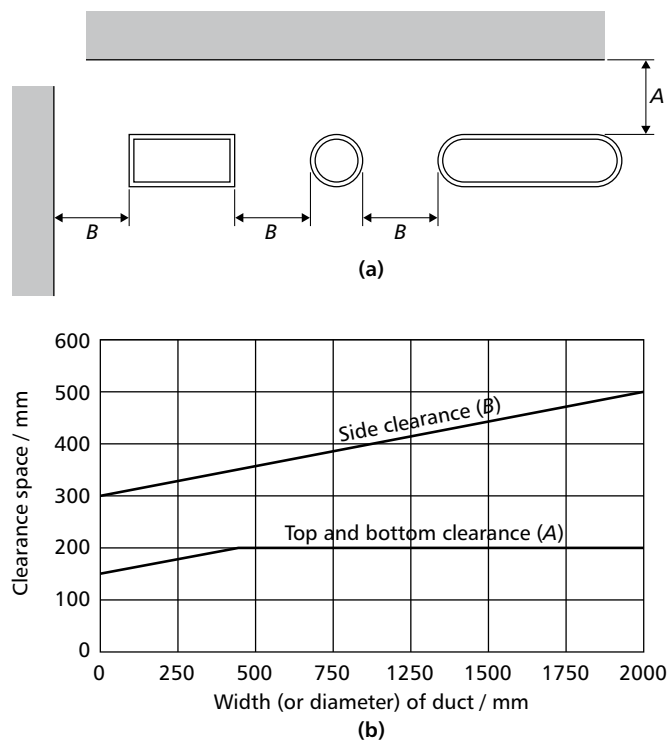

**Figure 2.A2.1** Space allowance for rectangular, circular and flat oval ductwork (a) schematic, (b) recommended clearances (reproduced from BSRIA Technical Note TN10/92 by permission of the Building Services Research and Information Association)

demountable to facilitate access for removal and replacement of filters, fans, motors or the complete unit, if necessary. Access should be provided which is at least equal to the full plan dimensions of the unit (including control and commissioning valves) plus a minimum allowance of 100 mm on all sides.

#### 2.A2.2.3 False ceilings and raised floors

Table 2.A2.1 shows typical floor-to-floor heights and the heights/depths of typical false floors/ceilings (Burberry, 1996). Figure 2.A2.5 illustrates some specific points.

## References

BSI (1997) BS 8313: 1997 *Code of practice for accommodation of building services in ducts* (London: British Standards Institution)

BSRIA (1992) *Space allowances for building services distribution systems — detail design stage* BSRIA Technical Note TN10/92 (Bracknell: Building Services Research and Information Association)

Burberry P (1996) *Architects Journal* 26 February 1986

DEO (1996) *Space requirements for plant access, operation and maintenance* Defence Estates Organisation (Works) Design and Maintenance Guide 08 (London: The Stationery Office)

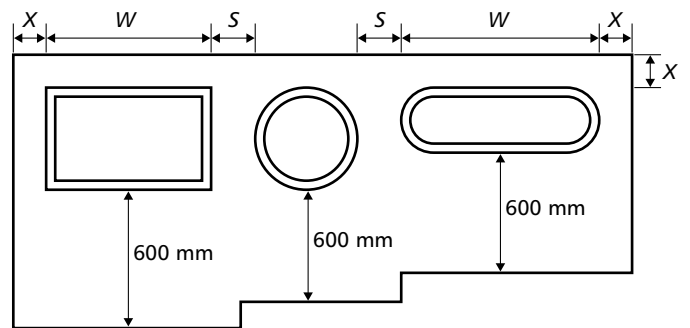

If  $W$  less than or equal to 1000 mm:  $X = 200$  mm,  $S = 400$  mm  
 If  $W$  greater than 1000 mm:  $X = 400$  mm,  $S = 600$  mm

(a) Insulated ducts

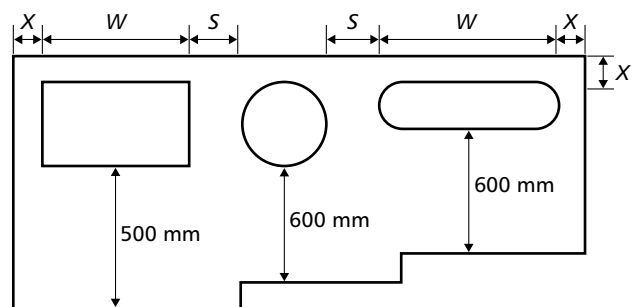

If  $W$  less than or equal to 1000 mm:  $X = 100$  mm,  $S = 300$  mm  
 If  $W$  greater than 1000 mm:  $X = 300$  mm,  $S = 400$  mm

(b) Uninsulated ducts

**Figure 2.A2.2** Space allowance for rectangular, circular and flat oval ductwork; (a) insulated, (b) uninsulated (reproduced from MoD Design and Maintenance Guide 08; © Crown copyright material is reproduced with the permission of the Controller of HMSO and Queen's Printer for Scotland)

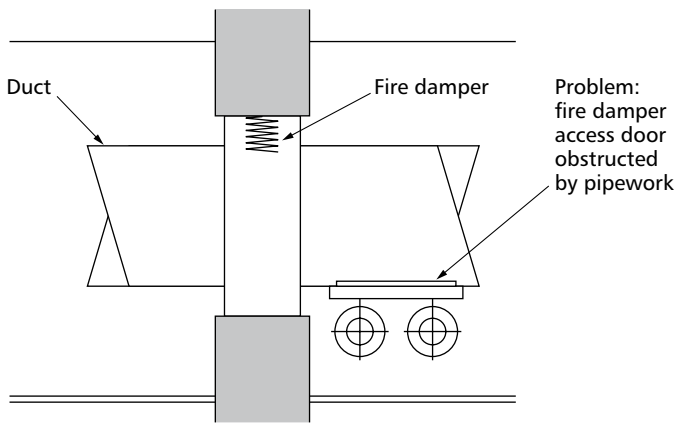

**Figure 2.A2.3** Common problems with access to fire dampers (reproduced from MoD Design and Maintenance Guide 08; © Crown copyright material is reproduced with the permission of the Controller of HMSO and Queen’s Printer for Scotland)

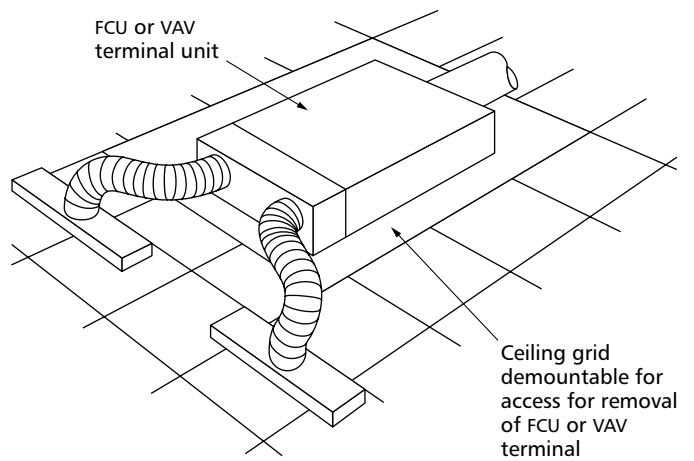
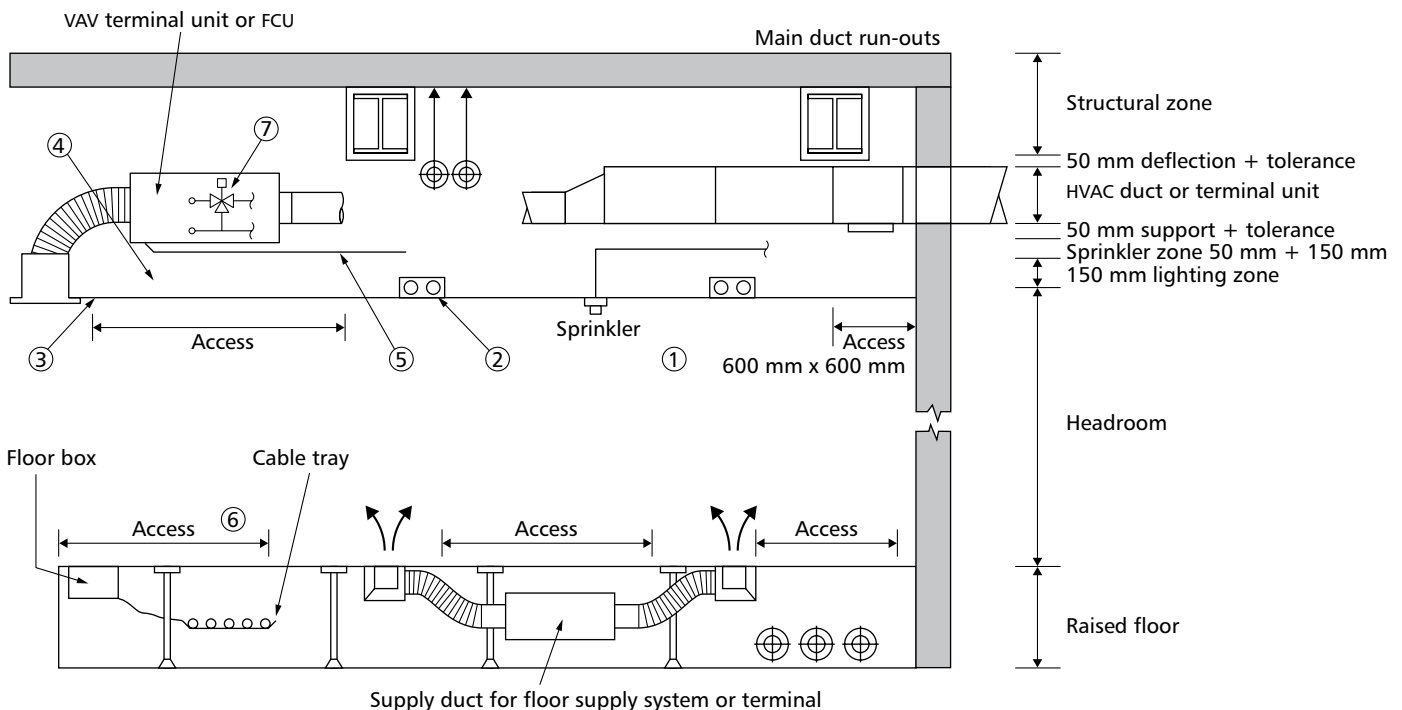

**Figure 2.A2.4** Typical ceiling-mounted terminal unit (reproduced from MoD Design and Maintenance Guide 08; © Crown copyright material is reproduced with the permission of the Controller of HMSO and Queen’s Printer for Scotland)

**Table 2.A2.1** Typical floor-to-floor heights and heights/depths of typical false floors/ceilings (Burberry, 1996) for offices

Office type	Typical floor-to-floor height / m	Typical false ceiling height / m	Typical false floor depth* / m
Average quality office, refurbished office; average requirements for IT and engineering services	3.6–3.8	0.5–0.6	—
High quality office, minimal perimeter systems; above average requirements for IT and engineering services	3.9–4.2	0.8–1.0	0.4–0.6

\* Option to reduce false ceiling height



- ① Ensure clear access to all fire dampers for inspection and testing
- ② Clearance of 1.5 times the luminaire depth to facilitate removal of the fitting
- ③ Demountable ceiling grid to permit access to the ceiling mounted terminal unit and removal
- ④ Clear access to the terminal unit for removal of the recirculation air filter (FCUs), cleaning of coil and condensate tray
- ⑤ Additional vertical space to be allowed for condensate drains and their fall (FCUs)
- ⑥ Access to raised floor shown for the situation where all floor tiles may not be removable
- ⑦ Provision should be made for permanent access to all commissioning and control valves

**Figure 2.A2.5** False ceilings and raised floors (reproduced from MoD Design and Maintenance Guide 08; © Crown copyright material is reproduced with the permission of the Controller of HMSO and Queen’s Printer for Scotland)

## Appendix 2.A3: Maximum permissible air leakage rates

BESA specification DW/144 (2013)w Table 22 provides maximum permissible air leakage rates. Figure 207 in DW/144 shows the permitted leakage at various pressures.

### Reference

BESA (2013) *Specification for Sheet Metal Ductwork* DW/144 (Penrith: BESA)

## Appendix 2.A4: Methods of fire protection

The following information is taken from BESA specification DW/144 (2013), which should be referred to for further information.

### 2.A4.1 Protection using fire dampers

The fire is isolated in the compartment of origin by the automatic or manual actuation of closures within the system. Fire dampers should, therefore, be sited at the point of penetration of a compartment wall or floor, or at the point of penetration of the enclosure of a protected escape route.

Fire dampers should be framed in such a way as to allow for thermal expansion in the event of fire, and the design must provide for the protection of any packing material included.

Standard types of fire dampers and frames are described in section 22 of DW/144.

### 2.A4.2 Protection using fire resisting enclosures

Where a building services shaft is provided through which the ventilation ductwork passes, and if the shaft is constructed to the highest standard of fire resistance of the structure which it penetrates, it forms a compartment known as a 'protected shaft'. This allows a complicated multiplicity of services to be transferred together through a shaft transversing a number of compartments and reaching remote parts of the building, without requiring further internal divisions along its length. The provision of fire dampers is then required only at points where the ventilation duct leaves the confines of the protected shaft. However, if there is only one ventilation duct and there are no other services within the protected shaft, between the fire compartment and the outside of the building, no fire dampers will be required.

### 2.A4.3 Protection using fire resisting ductwork

In this method of fire protection, the ductwork itself forms a protected shaft. The fire resistance may be achieved by the ductwork material itself, or through the application of a protective material. This is provided that the ductwork has been tested and/or assessed to BS 476: Part 24 (1987) with a fire resistance, when tested from either side, that should not be less than the fire resistance required for the elements of construction in the area through which it passes. It should also be noted that the fire resisting ductwork must be

supported with suitably sized and designed hangers, which reflect the reduction in tensile strength of steel in a fire condition, i.e.:

- fire resisting ductwork rated at 60 minutes (945 °C): tensile strength is reduced from 430 N·mm<sup>-2</sup> to 15 N·mm<sup>-2</sup>
- fire resisting ductwork rated at 120 minutes (1049 °C): tensile strength is reduced to 10 N·mm<sup>-2</sup>
- fire resisting ductwork rated at 240 minutes (1153 °C): tensile strength is reduced to 6 N·mm<sup>-2</sup>.

Where the fire resisting ductwork passes through a fire compartment wall or floor, a penetration seal must be provided which has been tested and/or assessed with the ductwork to BS 476: Part 24, to the same fire rating as the compartment wall through which the fire resisting ductwork passes. It should also be noted that where the fire resisting ductwork passes through the fire compartment wall or floor, the ductwork itself must be stiffened to prevent deformation of the duct in a fire to:

- maintain the cross-sectional area of the duct
- ensure that the fire rated penetration seal around the duct is not compromised.

### References

BESA (2013) *Specification for Sheet Metal Ductwork* DW/144 (Penrith: BESA)

BSI (1987) BS 476: *Fire tests on building materials and structures*; Part 24: 1987: *Method for determination of the fire resistance of ventilation ducts* (British Standards Institution) (1987)

## Appendix 2.A5: Example calculations

### 2.A5.1 Ductwork sizing and pressure drop calculations

Ductwork sizing is so inter-related to pressure drop that the two calculations must be handled together, as will be seen in the following worked example. The ductwork sizing example is in four parts, as follows:

- The first part leads through the ductwork with explanations of the reasons for the first choice of size for each section of ductwork. Some of the sizes could or should be changed later in the light of subsequent calculations. The simple example, see Figure 2.A5.1, is designed to incorporate several different components and illustrate the consequences and choices which can be made. Only the supply ductwork is shown.
- The second part includes the calculations of pressure drop, using data contained in CIBSE Guide C (2007), section 4. A separate but similar calculation would be required for the return ductwork.
- Amendment of some duct sizes in the light of the pressure drop calculations.
- Consideration of the outdoor air supply duct.

#### 2.A5.1.1 System design data

Figure 2.A5.1 illustrates a simple supply system to a suite of six private offices, each requiring  $0.2 \text{ m}^3\text{s}^{-1}$  of air. The main ductwork will be in the ceiling void of the corridors. Branches will be in ceiling voids within the offices. Outdoor air will constitute 40% of the total air being treated in the

air handling unit (AHU). The main air supply has a winter design temperature of  $30 \text{ }^\circ\text{C}$ .

For initial estimates only, the discharge diffusers will be assumed to give a pressure drop of 20 Pa for a flow of  $0.2 \text{ m}^3\text{s}^{-1}$ .

It is anticipated that the interior of the building will have a positive pressure of 15 Pa to allow exhaust air to be extracted naturally.

#### 2.A5.1.2 Preliminary sizing and explanation

From CIBSE Guide C<sup>(A6.1)</sup>, Appendix 4.A1, properties of air are as follows:

- at  $10 \text{ }^\circ\text{C}$ :  $\rho = 1.24 \text{ kg}\cdot\text{m}^{-3}$ ;  $\eta = 17.63 \times 10^{-6} \text{ kg}\cdot\text{m}^{-1}\cdot\text{s}^{-1}$ ;  $c_p = 1.011 \text{ kJ}\cdot\text{kg}^{-1}\cdot\text{K}^{-1}$
- at  $30 \text{ }^\circ\text{C}$ :  $\rho = 1.16 \text{ kg}\cdot\text{m}^{-3}$ ;  $\eta = 18.55 \times 10^{-6} \text{ kg}\cdot\text{m}^{-1}\cdot\text{s}^{-1}$ ;  $c_p = 1.030 \text{ kJ}\cdot\text{kg}^{-1}\cdot\text{K}^{-1}$ .

The minimum size of ductwork is constrained by acoustic considerations which limit air speeds. Otherwise life cycle costing should be the important factor. Thus, the limiting air velocities used as a starting point for duct sizing are as follows:

- *at external louvres*: air velocity,  $c = 2.5 \text{ m}\cdot\text{s}^{-1}$  (from CIBSE Guide C, Table 4.12)
- *in the AHU*: air velocity,  $c = 2 \text{ m}\cdot\text{s}^{-1}$  (face velocity; see Table 2.16)
- *in main duct*: air velocity,  $c = 6 \text{ m}\cdot\text{s}^{-1}$  (Table 2.16)

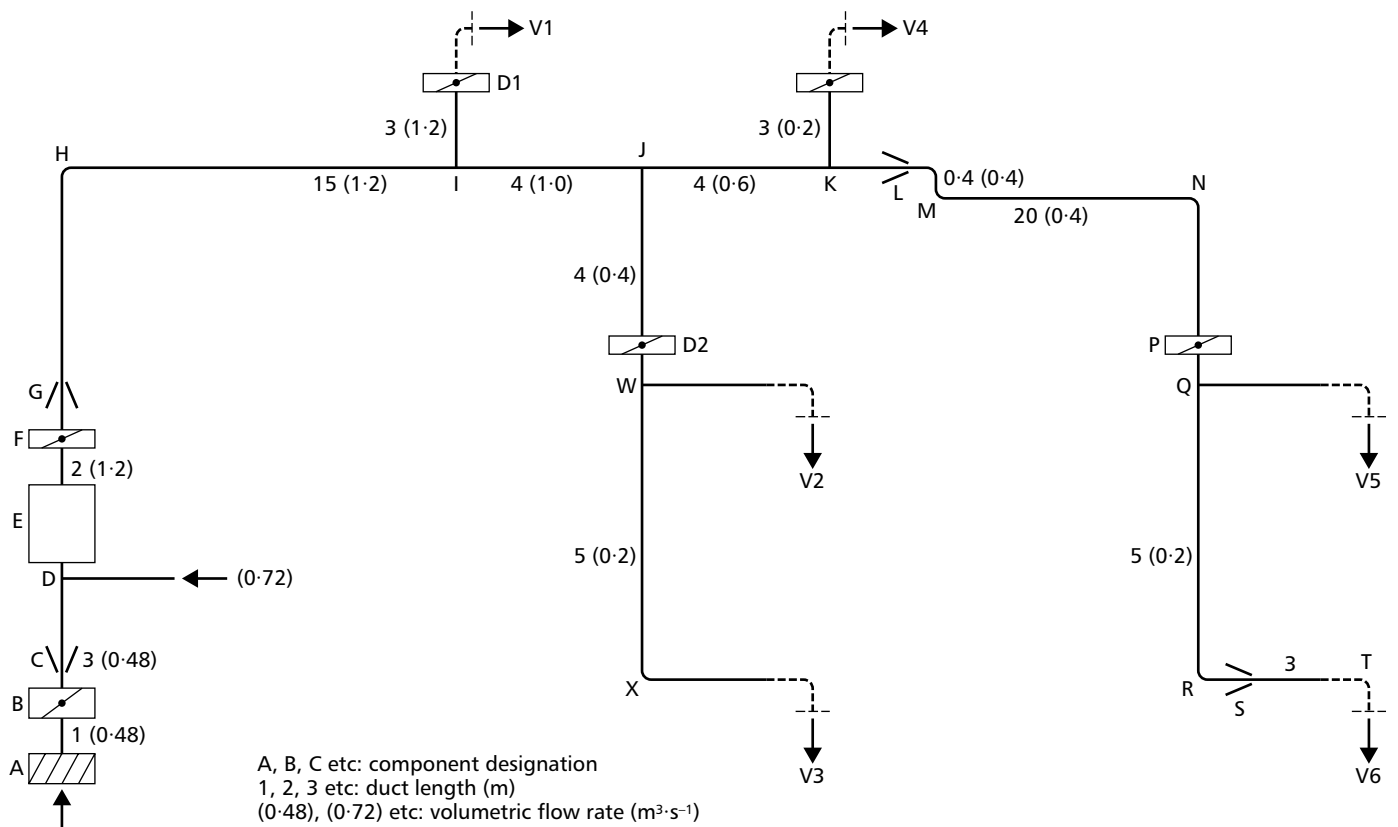

Figure 2.A5.1 Duct layout with lengths (m) and flow rates ( $\text{m}^3\text{s}^{-1}$ )

- *in branch duct*: air velocity,  $c = 5.5 \text{ m}\cdot\text{s}^{-1}$  (Table 2.16)
- *in final duct*: air velocity,  $c = 3 \text{ m}\cdot\text{s}^{-1}$  (Table 2.16)

### External louvres and mesh (A)

The pressure drop through louvres can be considerable. CIBSE Guide C, Table 4.35, recommends a maximum velocity of  $2.5 \text{ m}\cdot\text{s}^{-1}$  through the free area in a 'normal' situation. Provisionally assuming a 90% free area, this implies a maximum face velocity of  $2.25 \text{ m}\cdot\text{s}^{-1}$ .

For a total required airflow rate of  $1.2 \text{ m}^3\cdot\text{s}^{-1}$ , 40% of which is outdoor air, the airflow rate at the inlet is:

$$q = 0.4 \times 1.2 = 0.48 \text{ m}^3\cdot\text{s}^{-1}$$

Hence:

$$A_{\min} = q / c = 0.48 / 2.25 = 0.213 \text{ m}^2$$

From Appendix 2.A1, Table 2.A1.1, a rectangular duct measuring  $500 \text{ mm} \times 500 \text{ mm}$  has a cross-sectional area,  $A = 0.25 \text{ m}^2$ .

Substituting back into the previous equation gives velocity,  $c = 1.92 \text{ m}^3\cdot\text{s}^{-1}$

#### (a) External louvres

CIBSE Guide C, section 4, gives tentative guidance on the friction factor for louvred duct entries. Provisionally assuming louvre ratios, as defined in Guide C, of  $(h_i/h) = 0.7$  and  $(x/x_1) = 0.9$ , and louvres with vertical flat ends (case a), Guide C gives the pressure loss factor,  $\zeta = 4.8$ .

After selection of an appropriate louvre, the correct figure for pressure drop should be obtained from the manufacturer.

For a typical winter day, outdoor air might have a temperature of  $10^\circ\text{C}$ , hence  $\rho = 1.24 \text{ kg}\cdot\text{m}^{-3}$ .

#### (b) Bird mesh

Provisionally assume a free area of 70%. CIBSE Guide C suggests pressure loss factor,  $\zeta = 0.58$ .

### Outdoor air inlet damper (B)

Provisionally assuming for the moment that it will be an opposed blade damper with 3 blades, CIBSE Guide C suggests pressure loss factors based on the value of parameter  $x$ , given by:

$$x = n w / [2(h + w)]$$

where  $n$  is the number of blades, and  $w$  and  $h$  are the duct width (m) and height (m) respectively. Hence:

$$x = (3 \times 500) / [2 \times (500 + 500)] = 0.75$$

For the damper fully open ( $\theta = 0^\circ$ ), Guide C gives the pressure loss factor  $\zeta = 0.52$ .

After selection of an appropriate damper, the correct value should be obtained from the manufacturer.

Before continuing with the next item of ductwork, it is necessary to look ahead to the requirements of the air handling unit (E).

This will be handling airflow rate,  $q = 1.2 \text{ m}^3\cdot\text{s}^{-1}$ . Life cycle costing studies recommend a maximum face velocity of  $2 \text{ m}\cdot\text{s}^{-1}$  for an air handling unit. Hence:

$$A_{\min} = q / c = 1.2 / 2.0 = 0.6 \text{ m}^2$$

For this cross-sectional area, Appendix 2.A1, Table 2.A1.1, suggests a rectangular duct measuring  $1000 \text{ mm} \times 600 \text{ mm}$ , giving  $c = 2.0 \text{ m}\cdot\text{s}^{-1}$ .

In anticipation of the tee at D, requiring  $1000 \text{ mm} \times 600 \text{ mm}$ , an expansion taper is included at C. (Clearly there would be a case both for simplicity and a lowering of face velocity if the louvre size had been chosen as  $1000 \text{ mm} \times 600 \text{ mm}$  in the first place.)

After the AHU, the air has a temperature of  $30^\circ\text{C}$ , for which  $\rho = 1.16 \text{ kg}\cdot\text{m}^{-3}$ .

### Expansion (C)

BESA specification DW/144 (2013) suggests a maximum taper included angle of  $\theta = 45^\circ$ .

For expansion from  $(500 \times 500)$  to  $(1000 \times 600)$ :

$$A_2/A_1 = (1.0 \times 0.6) / (0.5 \times 0.5) = 2.4$$

For such small expansions the angle of the taper is not very important, so a value of  $\theta = 45^\circ$  is chosen.

The determination of  $\zeta$  is quite complex. For a quick calculation, a speculative value might provisionally be taken from the table, especially as this is not a large expansion. Nevertheless a full calculation is demonstrated here. A typical winter temperature of  $10^\circ\text{C}$  is chosen, but this is not critical.

Based on  $500 \times 500$ ,  $d_h = 500 \text{ mm}$  (from Appendix 2.A1, Table 2.A1.1). At (C), the airflow rate is:  $q = 0.48 \text{ m}^3\cdot\text{s}^{-1}$ . Hence, velocities before and after the expansion taper are:  $c_1 = 1.92 \text{ m}\cdot\text{s}^{-1}$  and  $c_2 = 0.8 \text{ m}\cdot\text{s}^{-1}$ . The Reynolds number is then given by:

$$\begin{aligned} Re_1 &= \rho c d / \eta = (1.24 \times 1.92 \times 0.5) / 17.63 \times 10^{-6} \\ &= 0.68 \times 10^5 \end{aligned}$$

Approximately, taking  $A_2/A_1 = 2$ , and  $Re = 1 \times 10^5$ , Guide C, Table 4.79 gives  $\zeta = 0.330$ . (More accurately, by graphical interpolation,  $\zeta = 0.50$ .)

### Tee, with shoe on the branch (D)

Note that for all tees, the value of  $\zeta$  is to be used with the velocity pressure of the combined flow. The velocity for the combined flow is given by:

$$c_c = 1.2 / (1.0 \times 0.6) = 2.0 \text{ m}\cdot\text{s}^{-1}$$

For converging flow, the ratio of straight flow rate to combined flow rate is:

$$q_s / q_c = 0.48 / 1.2 = 0.4$$

From CIBSE Guide C the pressure loss factor for straight flow is:  $\zeta_{s-c} = 0.22$ .

Assume that the branch, carrying  $0.72 \text{ m}^3\cdot\text{s}^{-1}$ , has a size  $300 \text{ mm} \times 400 \text{ mm}$ ; hence  $c = 6 \text{ m}\cdot\text{s}^{-1}$ . Therefore, ratio of branch flow rate to combined flow rate is:

$$q_b / q_c = 0.72 / 1.2 = 0.6$$

(Note that without a shoe, CIBSE Guide C, section 4.11.4.12, shows that the pressure loss factor for straight flow would have 0.46, i.e. twice that for a tee with a shoe on the branch.)

#### Air handling unit (AHU) (E)

The air handling unit, including heater battery, filter and fan, may be regarded as a 'black box' which must provide a pressure rise, external to itself, equal to the total pressure drop around the whole air circuit, supply and return.

#### Control damper, opposed blade, 3 blades (F)

As a first estimate, using CIBSE Guide C, section 4.11.4.18 (see above, section A6.1.2.2), parameter  $x$  is given by:

$$x = (3 \times 0.6) / [2 \times (0.6 + 0.6)] = 0.75$$

For the damper fully open ( $\theta = 0$ ), hence  $\zeta = 0.52$ .

After selection of the damper, the correct value must be obtained from the manufacturer.

#### Duct (G-H-I)

For a building containing private offices, Table 2.16 gives the maximum permitted velocity in a main duct as  $6 \text{ m}\cdot\text{s}^{-1}$ . This also accords with figures derived from life cycle costing.

Again, using the expression  $A = q / c$ , the required cross-sectional areas of the duct is:

$$A = 1.2 / 6.0 = 0.2 \text{ m}^2$$

Appendix 2.A1, Table 2.A1.1, suggests either  $600 \text{ mm}$  by  $400 \text{ mm}$ , or  $500 \text{ mm}$  by  $400 \text{ mm}$  ductwork. For this example  $500 \text{ mm}$  by  $400 \text{ mm}$  is chosen, and the orientation such as to make the following bend (H), an 'easy' bend, i.e.  $w = 400 \text{ mm}$ ,  $h = 500 \text{ mm}$ .

From the same table, the equivalent diameter is:

$$d_e = 492 \text{ mm}$$

#### Contraction (G)

For reduction from  $(1000 \times 600)$  to  $(400 \times 500)$ , the ratio of cross-sectional areas is:

$$A_2 / A_1 = (400 \times 500) / (1000 \times 600) = 0.333$$

The maximum taper recommended in BESA specification DW/144 is an included angle  $\theta = 45^\circ$ .

CIBSE Guide C, section 4.11.5.2, shows that for contractions the included angle is not important and  $\zeta$  is small. Note that  $\zeta$  is to be used with the outlet velocity,  $c_2$ . An included angle of  $45^\circ$  is chosen hence, from CIBSE Guide C by interpolation:  $\zeta = 0.055$ .

The outlet velocity is:

$$c_2 = q / A_2 = 1.2 / (0.4 \times 0.5) = 6.0 \text{ m}\cdot\text{s}^{-1}$$

#### Bend, with splitter vanes (H)

CIBSE Guide C section 4.11.4.2 applies. For  $400 < w < 800$ , Table 2.40 (based on BESA specification DW/144) recommends a single splitter vane. The BESA standard radius for bends is  $r = w$ , and this radius will be used. Hence:

$$h / w = 500 / 400 = 1.25$$

From CIBSE Guide C, Table 4.112,  $\zeta = 0.05$ .

Note that this value is considerably less than would have been the case without the vane.

#### Typical branch (I-D1-V1)

The 'index run', i.e. the pipe run likely to give the highest pressure loss, would appear to be the run from G to R to V6. In reality, it would depend upon the route taken by the return duct from the room supplied at V6.

Thus at the next few tees, it is necessary to consider only the pressure loss factors for straight flow,  $\zeta_{c-s}$ . Since the pressure drop incurred by tees depends upon the relative size of the branch, it is worth digressing at this point to consider the branches to the final run outs.

In this example, each final branch has the same flow. It is more convenient for the branches to be circular, especially as it is convenient to make the final connection to a diffuser by a flexible duct. However the length of such flexible ducts should be kept to a minimum as their pressure loss is high.

Taking a typical branch, I-D1-V1, assumed now to be within the office space, noise is the most important criterion, therefore velocity  $c < 3 \text{ m}\cdot\text{s}^{-1}$  (see Appendix 2.A1, Table 2.A1.1). Generally, even lower velocities are used, a velocity  $c = 2.5 \text{ m}\cdot\text{s}^{-1}$  will be assumed. Hence, the branch duct area is:

$$A = q / c = 0.2 / 2.5 = 0.08 \text{ m}^2$$

For a circular duct, this gives a minimum diameter  $d_{\min} = 319 \text{ mm}$ . This is so close to a standard size of  $315 \text{ mm}$  that the difference might be considered trivial. Furthermore this is a branch which provides an air route of minimum length and resistance. It is tempting to have the smaller diameter for this first branch and larger branches for the others, but this might lead to confusion for the installers. As the branch ducts are short it might be thought that the pressure drop will be small. However, the use of a short length of flexible ductwork for the final connection to the diffuser can add a disproportionate pressure drop. For these reasons,  $d = 315 \text{ mm}$  is chosen for the branch diameter.

For  $d_b = 315 \text{ mm}$ , the branch cross-sectional area is  $A_b = 0.0779 \text{ m}^2$ . Hence, the ratio of the cross-sectional area of the branch to that of the main duct flow is:

$$A_b / A_c = 0.0779 / (0.5 \times 0.4) = 0.390$$

The air velocity in the branch is:

$$c_b = q_b / A_b = 0.2 / 0.0779 = 2.57 \text{ m}\cdot\text{s}^{-1}$$

*Tee (with shoe) (I)*

For the rectangular main duct (500 × 400):  $A_c = 0.2 \text{ m}^2$ ,  $q_c = 1.2 \text{ m}^3\cdot\text{s}^{-1}$ , hence  $c_c = 6 \text{ m}\cdot\text{s}^{-1}$

For the circular branch ( $d = 315 \text{ mm}$ ):  $A_b = 0.0779 \text{ m}^2$ ,  $q_b = 0.2 \text{ m}^3\cdot\text{s}^{-1}$ .

Hence:

$$A_b / A_c = 0.0779 / 0.2 = 0.39$$

$$q_b / q_c = 0.2 / 1.2 = 0.166$$

$$q_s / q_c = 1.0 / 1.2 = 0.833$$

(Note that the pressure drop to the branch is less than it would be without the shoe, but is still considerably greater than that for the straight, which is to be expected.)

*Branch (J–X)*

This is required to carry  $0.4 \text{ m}^3\cdot\text{s}^{-1}$  with a limiting speed of  $5.5 \text{ m}\cdot\text{s}^{-1}$ . This implies a diameter of 304 mm. There would seem little option but to choose circular ductwork the next size up, i.e. 315 mm, though rectangular ductwork 300 mm × 250 mm could be chosen.

*Ducts (I–J and J–K)*

The straight runs I–J and J–K are short enough not to justify the complication of reductions in size, so, for convenience, the duct dimensions will remain the same as for ductwork run (G–H–I), i.e. 500 mm × 400 mm.

*Tee (with shoe) (J)*

For the rectangular main duct (500 mm × 400 mm):  $A_c = 0.2 \text{ m}^2$ ,  $q_c = 1.0 \text{ m}^3\cdot\text{s}^{-1}$ , hence  $c_c = 5 \text{ m}\cdot\text{s}^{-1}$ .

For the circular branch ( $d = 315 \text{ mm}$ ):  $A_b = 0.0779 \text{ m}^2$ ,  $q_b = 0.4 \text{ m}^3\cdot\text{s}^{-1}$ .

Hence:

$$A_b / A_c = 0.0779 / 0.2 = 0.39$$

$$q_b / q_c = 0.4 / 1.0 = 0.4$$

$$q_s / q_c = 0.6 / 1.0 = 0.6$$

*Tee (without shoe) (K)*

For the rectangular main duct (500 mm × 400 mm):  $A_c = 0.2 \text{ m}^2$ ,  $q_c = 0.6 \text{ m}^3\cdot\text{s}^{-1}$ , hence  $c_c = 3 \text{ m}\cdot\text{s}^{-1}$ .

For the circular branch ( $d = 315 \text{ mm}$ ):  $A_b = 0.0779 \text{ m}^2$ ,  $q_b = 0.2 \text{ m}^3\cdot\text{s}^{-1}$ .

Hence:

$$A_b / A_c = 0.0779 / 0.2 = 0.39$$

$$q_b / q_c = 0.2 / 0.6 = 0.667$$

*Duct (L–M–Q)*

This main branch could tolerate velocities up to  $5.5 \text{ m}\cdot\text{s}^{-1}$ . The ductwork could conveniently be circular.

Hence, for  $q = 0.4 \text{ m}^3\cdot\text{s}^{-1}$ :

$$A_{\min} = q / c = 0.4 / 5.5 = 0.0727 \text{ m}^2$$

$$d_{\min} = 304 \text{ mm}$$

A diameter of 315 mm could easily be chosen here, but since this is the index run, it is advisable to minimise pressure losses along this run as this will make subsequent balancing easier. Therefore the next size up is selected:  $d = 355 \text{ mm}$ .

Hence:

$$A_c = 0.100 \text{ m}^2$$

*Contraction, rectangular to circular (L)*

For reduction from rectangular (500 mm × 400 mm) to circular ( $d = 355 \text{ mm}$ ), with a maximum taper angle of  $\theta = 45^\circ$ , CIBSE Guide C, section 4.11.5 applies.

$$A_2 / A_1 = 0.1 / 0.2 = 0.5$$

*Segmented bends in close proximity (M)*

CIBSE Guide C, section 4.11.2.5 applies. Separation of bends,  $l = 400 \text{ mm}$ , so  $(l / d) = 400 / 355 = 1.1$ ;  $(r / d) = 1$  for each bend. The Reynolds number is given by:

$$\begin{aligned} Re &= \rho c d / \eta = 1.16 \times 4.0 \times 0.355 / (18.55 \times 10^{-6}) \\ &= 0.888 \times 10^5 \end{aligned}$$

*90° segmented bend (N)*

By interpolation, from CIBSE Guide, Table 4.119, for  $(r / d) = 1$ ,  $R_c = 0.9 \times 105$ ,  $d = 355 \text{ mm}$ :

$$\zeta = 0.305$$

*Fire damper (P)*

This should have a totally clear area when open, presenting a small resistance. Provisionally, until manufacturer's data are available, assume  $\zeta = 0.12$ .

*Tee (without shoe) (Q)*

For the circular main duct ( $d_c = 355 \text{ mm}$ ):  $A_c = 0.10 \text{ m}^2$ ,  $q_c = 0.4 \text{ m}^3\cdot\text{s}^{-1}$ .

For the circular branch ( $d_b = 315 \text{ mm}$ ):  $A_b = 0.0779 \text{ m}^2$ ,  $q_b = 0.2 \text{ m}^3\cdot\text{s}^{-1}$ .

Hence:

$$A_b / A_c = 0.0779 / 0.10 = 0.78$$

$$q_b / q_c = 0.2 / 0.4 = 0.5$$

*Duct (Q–R)*

Logically, the diameter could be reduced to 315 mm. However, since this is the index run, it is better to minimise

pressure loss, therefore it is better to maintain the duct diameter as 355 mm until after the final bend R.

### 90° segmented bend (R)

The air velocity is given by:

$$c = q / A = 0.2 / 0.1 = 2.0 \text{ m}\cdot\text{s}^{-1}$$

Hence, the Reynolds number is:

$$\begin{aligned} Re &= \rho c d / \eta = 1.16 \times 2.0 \times 0.355 / (18.55 \times 10^{-6}) \\ &= 0.44 \times 10^5 \end{aligned}$$

### Symmetrical contraction (S)

For reduction from  $d_1 = 355 \text{ mm}$  to  $d_2 = 315 \text{ mm}$ , ratio of cross-sectional areas is:

$$A_2 / A_1 = (315 / 355)^2 = 0.79$$

CIBSE Guide C, section 4.11.2.8 applies. For an included angle  $\theta = 45^\circ$ , CIBSE Guide C, Table 4.57 gives, by extrapolation:  $\zeta = 0.055$ .

The outlet velocity is:

$$c_2 = q / A_2 = 0.2 / 0.0779 = 2.57 \text{ m}\cdot\text{s}^{-1}$$

### 90° segmented bend (T)

The Reynolds number is given by:

$$\begin{aligned} Re &= \rho c d / \eta = 1.16 \times 2.57 \times 0.315 / (18.55 \times 10^{-6}) \\ &= 0.51 \times 10^5 \end{aligned}$$

### Diffuser (V)

Provisionally, take:

$$\Delta p = 20 \text{ Pa}$$

## 2.A5.1.3 Calculation of pressure drop

For each duct fitting, along what is believed to be the index run, the pressure drop is given by:

$$\Delta p_i = \zeta^{1/2} \rho c^2$$

Appropriate values have already been obtained in section 2.A5.1.2 above, and a table of the calculations is shown as Table 2.A6.1.

For the straight lengths of duct, Figure 2.33 is used to obtain the pressure drop per unit length. The calculations are shown in Table 2.A5.2.

The pressure drops obtained in Tables 2.A5.1 and 2.A5.2 are summed to give a drop in total pressure of 70.4 Pa.

## 2.A5.1.4 Amendment to duct sizes to improve balance

Although the duct sizing has, by normal criteria, been on the generous side, the pressure drop along the index run is nevertheless dominated by the pressure drop along G–I and L–Q. If the design is left as it is, then branch run (I–D1–V1) will require considerable additional resistance by

closing damper D1, which could cause additional noise generation. Furthermore, the system pressure drop will consequently always be greater and incur constant additional fan power and energy costs. Consideration should always be given to the alternative solution of reducing the pressure loss in the index run by increasing the duct size along the ‘problem’ runs. To illustrate this, the duct size from L–S could be increased to the next size up.

Table 2.A5.3 illustrates the effect of increasing the diameter of duct run (L–S) from 355 mm to 400 mm. The effect is to reduce friction pressure drop by 10.8, some 16% of the total pressure drop, which would be worth achieving.

Table 2.A5.4 gives a break-down of the pressure drop incurred along the index run to V6 with the increased duct sizes. The drop in total pressure is now 59.7 Pa.

Before finally accepting these design sizes, it is worth checking on the pressure drop incurred by the airflow along the shortest duct run, namely E to V1, see Table 2.A6.5.

Note that the pressure drops along the index run (see Table 2.A5.4) and along the shortest run (see Table 2.A5.5) are now almost in balance, being 59.7 and 61.2 Pa respectively. This is due to the decision to employ larger size ductwork along the index run, and also to the fact that flow round to the branch at tee I is considerably more than along the straight, despite the shoe. Normally the control damper D1 would need to provide an additional pressure drop, but in this instance it is not necessary. Similar calculations should be carried out for each air route.

Assuming that all the air flow runs can be adjusted to have the same loss of total pressure, the ‘design flow rates’ should then occur. Note that the total pressure drop for the circuit is only that for one circuit as all the routes are in parallel.

At this stage the return ductwork has been neither designed nor sized. The exercise is similar to the above calculations for the supply ductwork. In this example, only 60% of the total air flow is to be recirculated. The pressure drops calculated would in general be very similar, except to note that the pressure drop through an extract grille will, or should be, considerably less than that through a supply diffuser. For the purposes of this example, a return airflow of  $0.72 \text{ m}^3\cdot\text{s}^{-1}$  is assumed, incurring a pressure drop of 50 Pa. This would give rise to a total pressure drop for the circuit of  $(60 + 50) \text{ Pa} = 110 \text{ Pa}$ .

Note that a cost–benefit analysis of enlarging duct L–S might not in isolation justify such enlargement. However, the ‘knock-on’ effects should not be overlooked; i.e. the pressure drop on the other four air routes would be affected such that dampers in non-index run routes might require less trimming. It has already been shown that, for example, damper D1 will require no measurable trimming.

The final duct layout using the amended duct sizes is shown in Figure 2.A6.2.

## 2.A5.1.5 Outdoor air supply

Note that, up to this point, the effect of the outdoor air inlet has not been considered because it does not constitute part of the main airflow loop. A few assumptions will now be made to illustrate the effect.

Suppose that the air leaks from each room to the external air resulted in the air within each room having a pressure of 15 Pa above the pressure outside the building. The pressure drop in the return ductwork ( $\Delta p_r$ ) was found to be 50 Pa (see section 2.A5.1.4). Thus, the total pressure just before the air handling unit (E), will be  $(-50 + 15)$  Pa = -35 Pa.

Table 2.A5.6 draws together the fresh air inlet duct calculations from Tables 2.A5.1 and 2.A5.2. This shows that, for the design flow of outdoor air, the pressure drop is

15.0 Pa. This needs to be 35 Pa so that the right quantity of outdoor air is drawn in. This can be achieved either by closing down damper B considerably, or by selecting a smaller louvre and mesh screen.

These considerations of the outdoor air supply duct have no bearing on the fan selection which follows.

**Table 2.A5.1** Calculation of pressure drops for fittings in the index run of supply ductwork (E–V6)

Item	Description	Guide C table ref.	Appropriate air velocity	Air velocity / $\text{m}\cdot\text{s}^{-1}$	$(\frac{1}{2} \rho c^2)$ / Pa	Pressure loss factor, $\zeta$	Pressure drop, $\Delta p$ / Pa
A <sub>1</sub>	Louvre	4.104	—	1.92	2.29	4.8*	11.0
A <sub>2</sub>	Mesh screen	4.102	—	1.92	2.29	0.58	1.3
B	Outdoor air inlet damper	4.78	—	1.92	2.29	0.52*	1.2
C	Expansion taper	4.79	$c_1$	1.92	2.29	0.33	0.8
D	Tee, shoe, converging (straight flow)	4.88	$c_c$	2.0	2.48	0.22	0.5
D	Tee, shoe, converging (branch flow)	4.89	$c_c$	2.0	2.4	1.03	2.5
E	Air handling unit (AHU)	—	—	—	—	—	—
F	Damper	4.78	—	2.0	2.32	0.52*	1.2
G	Contraction taper (rect.)	4.80	$c_2$	6.0	20.9	0.055	1.1
H	90° bend with vane (rect.)	4.63	—	6.0	20.9	0.05	1.0
I	Tee, shoe, diverging	4.108	$c_c$	6.0	20.9	0.012	0.3
J	Tee, shoe	4.108	$c_c$	5.0	14.5	0	0
K	Tee	4.108	$c_c$	3.0	5.22	0.045	0.2
L	Contraction taper (rect. → circ.)	4.80	$c_2$	4.0	9.28	0.055	0.5
M	Double bend	4.122	—	4.0	9.28	0.58	5.4
N	Bend	4.119	—	4.0	9.28	0.305	2.8
P	Fire damper	—	—	4.0	9.28	0.12*	1.1
Q	Tee	4.133	$c_c$	4.0	9.28	0	0
R	Bend	4.119	—	2.0	2.32	0.35	0.8
S	Contraction (circ.)	4.126	$c_2$	2.57	3.83	0.055	0.2
T	Bend	4.119	—	2.57	3.83	0.36	1.4
V6	Diffuser	—	—	—	—	—	20.0*
Total (E–V6):							36.0
I	Tee (branch flow)	4.108	$c_c$	6	20.9	0.83	17.3

\* provisional value to be replaced with manufacturer's data following selection of equipment

Note: items A, B and C have not been added into the total, as the outdoor air supply is not in series with the return ductwork and will have to be considered separately later. Similarly, although the pressure drops across tee D have been illustrated, this would constitute part of the calculations for the return air ductwork.

**Table 2.A5.2** Calculations for straight ductwork in the index run of supply ductwork (E–V6)

Run	Air velocity, $c$ / $\text{m}\cdot\text{s}^{-1}$	Duct length / m	Flow rate, $q$ / $\text{m}^3\cdot\text{s}^{-1}$	Dimensions / (mm × mm)	Equiv. diam., $d_c$ / mm	$\Delta p / l$ / $\text{Pa}\cdot\text{m}^{-1}$	Pressure drop, $\Delta p$ / Pa
A–B	1.92	1	0.48	500 × 500	545	0.09	0.1
C–D	0.8	3	0.48	1000 × 600	848	0.01	0
E–G	2.0	2	1.2	1000 × 600	848	0.01	0
G–I	6.0	15	1.2	500 × 400	492	1.0	15.0
I–J	5.0	4	1.0	500 × 400	492	0.75	3.0
J–K	3.0	4	0.6	500 × 400	492	0.29	1.2
K–L	2.0	1	0.4	500 × 400	492	0.13	0.1
L–Q	4.0	20.4	0.4	—	355	0.6	12.2
Q–S	2.0	5	0.2	—	355	0.16	0.8
S–T	2.57	3	0.2	—	315	0.34	1.0
T <sub>1</sub> –T <sub>2</sub>	2.57	0.4	0.2	—	315	$8 \times 0.35^*$	1.1
Total (E–T <sub>2</sub> ):							34.4

\* Flexible duct giving estimated pressure drop of 8 times that of smooth duct

Note: pressure drops along A–B and C–D have not been added into the total, as the fresh air supply is not in series with the return ductwork, and will have to be considered separately later.

**Table 2.A5.3** Effect of a increasing diameter for duct run L–S

Item	Description	Length, <i>l</i> / m	$\Delta p / l$ Pa·m <sup>-1</sup>	Pressure loss factor, $\zeta$	$(\frac{1}{2}\rho c^2)$ / Pa	New pressure drop, $\Delta p$ / Pa	Old pressure drop, $\Delta p$ / Pa	Reduction / Pa
L–Q	Duct	20.4	0.28	—	—	6.1	12.2	6.1
Q–S	Duct	5	0.075	—	—	0.4	0.8	0.4
L	Contraction	—	—	0.055	5.88	0.3	0.5	0.2
M	Double bend	—	—	0.532	5.88	3.1	5.4	2.3
N	Bend	—	—	0.28	5.88	1.6	2.8	1.2
P	Fire damper	—	—	0.12*	5.88	0.7	1.1	0.4
Q	Tee	—	—	0.05	5.88	0.3	0	-0.3
R	Bend	—	—	0.282	1.47	0.4	0.9	0.5
S	Contraction	—	—	0.055	10.4	0.2	0.2	0
Total saving:								10.8

\* provisional value to be replaced with manufacturer's data following selection of equipment

**Table 2.A5.4** Table of final calculations for ductwork and fittings in the index run (E–V6)

Item	Description	Dimensions / (mm × mm)	Length, <i>l</i> / m	$\Delta p / l$ / Pa·m <sup>-1</sup>	Air vel., <i>c</i> / m·s <sup>-1</sup>	$(\frac{1}{2}\rho c^2)$ / Pa	Press. loss factor, $\zeta$	Press. drop, $\Delta p$ / Pa
E–G	Duct	1000 × 600	2	0.01	2	2.4	—	0
F	Damper	1000 × 600	—	—	2	2.4	0.52*	1.2
G	Contraction taper (rect.)	—	—	—	6	20.9	0.055	1.1
H	90° bend, with vane (rect.)	500 × 400	—	—	6	20.9	0.05	1.0
G–I	Duct	500 × 400	15	1.0	6	20.9	—	15.0
I	Tee, shoe, diverging	500 × 400	—	—	6	20.9	0.012	0.3
I–J	Duct	500 × 400	4	0.75	5	14.5	—	3.0
J	Tee	500 × 400	—	—	5	14.5	0	0
J–K	Duct	500 × 400	4	0.29	3	5.22	—	1.2
K	Tee	500 × 400	—	—	3	5.22	0.045	0.2
K–L	Duct	500 × 400	1	0.13	2	2.32	—	0.1
L	Contraction taper (rect. → circ.)	400	—	—	3.18	5.88	0.055	0.3
M	Double bend (circ.)	400	—	—	3.18	5.88	0.536	3.1
N	Bend (circ.)	400	—	—	3.18	5.88	0.282	1.6
P	Fire damper (circ.)	400	—	—	3.18	5.88	0.12*	0.7
L–Q	Duct (circ.)	400	20.4	0.3	3.18	5.88	—	6.1
Q	Tee, without shoe (circ.)	400	—	—	3.18	5.88	0.05	0.3
R	Bend (circ.)	400	—	—	1.59	1.5	0.282	0.4
Q–S	Duct (circ.)	400	5	0.075	1.59	1.5	—	0.4
S	Contraction (circ.)	400 □ 315	—	—	2.57	3.96	0.055	0.2
T	Bend (circ.)	315	—	—	2.57	3.96	0.36	1.4
S–T	Duct (circ.)	315	3	0.34	2.57	3.96	—	1.0
T–T	Flexible duct (circ.)	315	0.4	2.8*	2.57	3.96	—	1.1
V6	Diffuser	—	—	—	—	—	—	20.0*
Total (E–V6):								59.7
I	Tee (branch flow)	315	—	—	6	20.9	0.83	17.3

\* provisional value to be replaced with manufacturer's data following selection of equipment

## 2.A5.2 Choice of fan or air handling unit (AHU)

### 2.A5.2.1 Fan specification

The air handling unit will be required to provide, external to the unit, an increase in total pressure of 110 Pa for a volumetric airflow rate of 1.2 m<sup>3</sup>·s<sup>-1</sup>.

The question of margins or safety factors sometimes arises. There is little point in adding a margin to both the air flow and to the pressure drop since an increased air flow in the calculations automatically causes a larger pressure drop. For low pressure ductwork, air leakage is likely to be trivial so there is no need to add a safety margin. However, although the accuracy of the pressure drop data has

**Table 2.A5.5** Final pressure drops for shortest run (E–V1)

Item	Description	Length, <i>l</i> / m	Dimensions / (mm × mm)	Pressure drop, $\Delta p$ / Pa
D–G	Straight duct	2.0	1000 × 600	0
G–I	Straight duct	15.0	500 × 400	15.0
I–V1	Straight duct	3.0 + 0.4	315 (diam.)	2.1
G	Contraction	—	—	1.1
H	Bend	—	500 × 400	1.0
I	Tee (branch flow)	—	500 × 400	17.3
T	Bend	—	315 (diam.)	1.4
F	Damper	—	1000 × 600	1.2*
D1	Damper	—	315 (diam.)	2.1*
V1	Diffuser	—	—	20.0*
Total (supply run) (E–V1):				61.2

\* provisional value to be replaced with manufacturer's data following selection of equipment

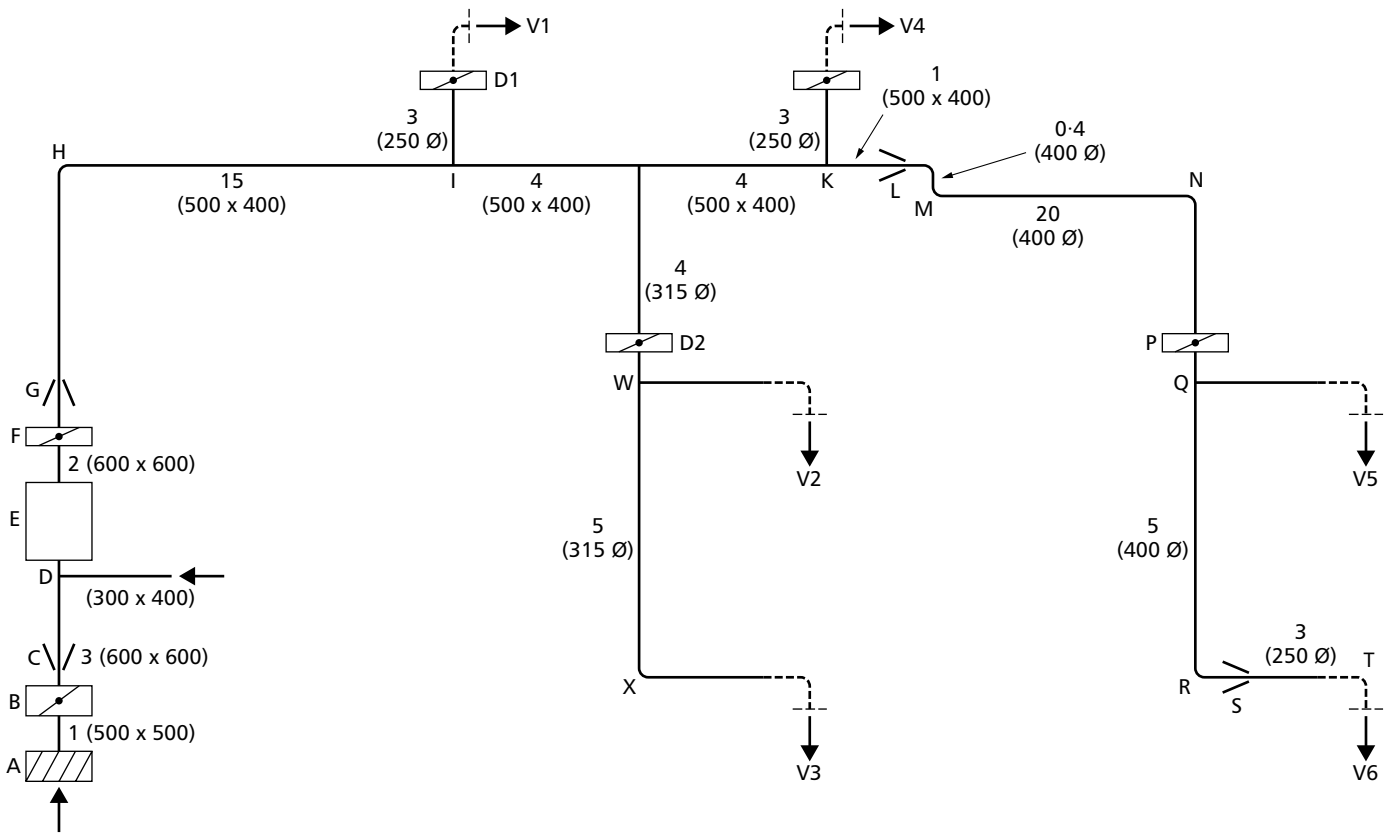

A, B, C etc: component designation  
 1, 2, 3 etc: duct length (m)  
 (500 x 400) etc: rectangular duct dimensions (mm)  
 (315 Ø) etc: circular duct diameter (mm)

Figure 2.A5.2 Final duct layout with lengths (m) and sizes (mm)

improved considerably over recent years, the published values are not precise. Therefore a margin of 10% could be added.

If a margin of 10% is added to the estimated pressure loss calculation of the ductwork, the air handling unit would be required to provide a rise in total pressure of 121 Pa for a flow of 1.2 m<sup>3</sup>·s<sup>-1</sup>.

Within the air handling unit there will be a considerable pressure drop through the filter and through the heat exchanger (also known as the ‘heating coil’). However, for packaged units it is the responsibility of the supplier to select the fan so as to meet the pressure drop of the components within the unit and the ductwork.

If the fan is selected independently of any packaged air handling unit, then it is to be hoped that matching the system characteristic to the fan performance characteristic will result in an operating point somewhere near the point of maximum efficiency. If not, further amendments to the duct sizes might prove advisable. If the estimated level of the fan noise is found to be excessive, then the inclusion of sound attenuators may be necessary; this would add appreciably to the pressure drop and may require a different fan to be chosen.

2.A5.2.2 Specific fan power

Building Regulations Approved Document L imposes a limit on ‘specific fan power’. This is defined as the sum of the design total circuit-watts, including all losses through switchgear and controls such as inverters, of all fans that supply air and exhaust it back outdoors (i.e. the sum of the supply and extract fans), divided by the design ventilation rate through the building.

For AC/MV systems in new buildings, the SFP should be no greater than 2 W·s·litre<sup>-1</sup>, i.e. 2 kW·s·m<sup>-3</sup>.

Table 2.A5.6 Pressure drops for outdoor air supply (A–E)

Item	Description	Length, l / m	Dimensions / (mm × mm)	Pressure drop Δp / Pa
A–B	Straight duct	1.0	500 × 500	0.1
C–E	Straight duct	3.0	1000 × 600	0
A	Louvre/mesh screen	—	500 × 500	12.3
B	Outdoor air inlet damper	—	500 × 500	1.2
C	Expansion taper	—	—	0.8
D	Tee, shoe, converging (straight flow)	—	—	0.5
Total (A–E):				15.0

It is impossible at this stage to predict the electrical power consumption of the AHU, which has yet to be selected. However, since the total outside air requirement is  $1.2 \text{ m}^3 \cdot \text{s}^{-1}$ , the SFP will limit the consumption to 2.4 kW.

To illustrate the consequences, the following assumptions will be made:

- fan total efficiency,  $\eta_f = 80\%$
- fan motor efficiency,  $\eta_m = 85\%$
- pressure drop across the filter and heat exchanger = 200 Pa

From section 2.A5.1.4, the pressure drops for the supply and return ductwork are 60 Pa and 50 Pa, respectively. Therefore, the total pressure rise (including 10% margin) required is given by:

$$\begin{aligned} & [(\Delta p_{t(\text{supply})} + \Delta p_{t(\text{return})}) \times 1.1] + \Delta p_{t(\text{other components})} \\ & = (110 \times 1.1) + 200 = 321 \text{ Pa} \end{aligned}$$

The air power required is:

$$q \Delta p = 1.2 \times 321 \text{ m}^3 \cdot \text{s}^{-1} \cdot \text{Pa} = 385 \text{ W}$$

Total electrical power required for fans:

$$P_e = (q \Delta p) / \eta_f \eta_m = 385 / (0.8 \times 0.85) = 0.566 \text{ kW}$$

Specific fan power:

$$\text{SFP} = P_e / q = 0.566 / 1.2 = 0.472 \text{ kW} \cdot \text{s} \cdot \text{m}^{-3}$$

This is well within the limit imposed by Approved Document L2, as would be expected for the very simple system used in the example. A larger, more realistic system, with more tortuous duct runs and sound attenuators, would incur much greater pressure losses, necessitating a more powerful fan and motor, and thus lead to a higher specific fan power.

### 2.A5.3 Air leakage

Up to this point, only total pressure and drops in total pressure of the air have been considered. However, air leakage depends upon the actual pressure (static pressure) of the air in the duct relative to that outside the duct. It is impossible to predict this value, though it can be measured after installation. The following illustrates the calculation of the permissible air leakage.

Air leakage is given by:

$$q_L = C A_s p^{0.65} \quad (2.A5.1)$$

where  $q_L$  is the air leakage rate ( $\text{litre} \cdot \text{s}^{-1}$ ),  $C$  is a constant ( $\text{litre} \cdot \text{s}^{-1} \cdot \text{m}^{-2} \cdot \text{Pa}^{-0.65}$ ) and  $p$  is the static pressure in the duct relative to the air outside the duct (Pa).

For low pressure ductwork,  $C = 0.025 \text{ litre} \cdot \text{s}^{-1} \cdot \text{m}^{-2} \cdot \text{Pa}^{-0.65}$ .

It is possible to calculate the leakage progressively along the duct in accordance with the change in pressure of the duct air. However, for simplicity, the pressure at the mid-length position only of each length of duct will be considered.

The mean pressure in a duct will be approximately equal to the pressure half way along the duct, and is given by:

$$p = p_{t1} - 1/2 \Delta p - 1/2 \rho c^2 \quad (2.A5.2)$$

where  $p$  is the mean pressure in the duct (Pa),  $p_{t1}$  is the total pressure at the beginning of the duct (Pa),  $\Delta p$  is the pressure loss along the duct (Pa),  $\rho$  is the density of the air in the duct ( $\text{kg} \cdot \text{m}^{-3}$ ) and  $c$  is the air velocity in the duct ( $\text{m} \cdot \text{s}^{-1}$ ).

The drop in total pressure along the supply air ductwork is 59.7 Pa (see section 2.A5.1.4). This means that the total pressure at the exit from the AHU will be 59.7 Pa above that of the room. That is the starting point for the calculations shown in Table 2.A5.7. However, to illustrate the procedure, the leakage from duct run J–K is calculated as follows.

Surface area of duct = duct length  $\times$  perimeter. Hence:

$$A_s = 4 \times [2 \times (0.5 + 0.4)] = 7.2 \text{ m}^2$$

The pressure loss up to and just past tee J is the sum of the first eight items of Table 2.A5.4, i.e.:

$$\Delta p = 21.6 \text{ Pa}$$

Total pressure at start of duct run J–K is the total pressure at E minus the pressure drop up to tee J:

$$p_{t1} = 59.7 - 21.6 = 38.1 \text{ Pa}$$

From Table 2.A5.4,  $1/2 \rho c^2$  for duct run J–K is 5.22 Pa. The pressure drop halfway along J–K is  $(0.5 \times 1.2)$  Pa. Therefore, using equation 2.A5.2, the mean static pressure half way along duct run J–K is:

$$p = 38.1 - 0.6 - 5.22 = 32.3 \text{ Pa}$$

Hence, using equation 2.A5.1, the air leakage is:

$$q_L = 0.025 \times 7.2 \times 32.3^{0.65} = 1.72 \text{ l} \cdot \text{s}^{-1}$$

In Table 2.A5.7, note that although the value of total pressure has been dropping consistently along the duct, in this portion of duct J–K, the actual pressure of the air is greater than in the preceding section. This is due to an accidental element of 'static regain'. At tee I, the main duct section has not changed although less air flows along the main duct after the branch. Thus in this section the air velocity, and thus the value of  $(1/2 \rho c^2)$ , has diminished. This occurs at every tee, as shown in Table 2.A5.7 for runs K–L and Q–S.

Table 2.A5.7 suggests that the maximum leakage would be  $20.8 \text{ l} \cdot \text{s}^{-1}$ . Therefore the permissible fraction lost through air leakage is 1.7% of the original flow rate of  $1.2 \text{ m}^3 \cdot \text{s}^{-1}$  (i.e.  $1200 \text{ l} \cdot \text{s}^{-1}$ ). This does not justify specifying a higher flow rate, nor a recalculation of the pressure drop.

Note that the air in much of the return ductwork will be found to have negative static pressure, i.e. the pressure in the duct will be lower than the surroundings, so there will be air leaks into the ductwork.

### 2.A5.4 Drop in air temperature along the duct

#### 2.A5.4.1 Uninsulated ductwork

Table 2.A5.8 shows the calculation of heat loss from the index run assuming uninsulated ductwork having a thermal

transmittance ( $U$ -value) of  $7.89 \text{ W}\cdot\text{m}^{-2}\cdot\text{K}^{-1}$ . The air temperatures inside and outside the duct are:

- temperature of air inside the duct at beginning of run,  $t_{\text{ad1}} = 30 \text{ }^\circ\text{C}$
- temperature of air surrounding the duct,  $t_{\text{as}} = 20 \text{ }^\circ\text{C}$ .

Table 2.A5.8 shows that, along the index run E–V6, the heat loss is 4.98 kW, possibly being dissipated into a region that does not require heating. If the ductwork were situated in ceiling voids, which consequently became over-heated, then the heat loss would be less due to the higher temperature outside the duct. Of greater importance is that the temperature of the air at the end of the run will be significantly below the desired supply temperature of  $30 \text{ }^\circ\text{C}$ . Table 2.A5.8 shows that the temperature of the supply air to zone V6 will be  $23.5 \text{ }^\circ\text{C}$ , which will be inadequate. Clearly, it is recommended that ductwork carrying heated or cooled air should be insulated.

#### 2.A5.4.2 Insulated ductwork

Table 3.8 gives recommended thickness of insulation for ductwork depending on the thermal conductivity ( $\lambda$ ) of the insulation material. In the following example,  $\lambda = 0.035 \text{ W}\cdot\text{m}^{-1}\cdot\text{K}^{-1}$ . The duct air temperature is nominally  $30 \text{ }^\circ\text{C}$  and the temperature of the surrounding air is  $20 \text{ }^\circ\text{C}$ , i.e. ( $t_{\text{ad1}} - t_{\text{a}} = 10 \text{ K}$ ).

From Table 2.21, the recommended thickness for a duct carrying air at a temperature 10 K greater (or less) than the surroundings, and for a thermal conductivity  $\lambda = 0.035 \text{ W}\cdot\text{m}^{-1}\cdot\text{K}^{-1}$ , is 50 mm. From Table 3.7, the overall thermal transmittance is  $U = 0.64 \text{ W}\cdot\text{m}^{-2}\cdot\text{K}^{-1}$ .

For simplicity, it is assumed that the temperature drop along a section is trivial.

Taking duct run I–J as an example:

Surface area of duct = duct length  $\times$  perimeter. Hence:

$$A_s = 4 \times [2 \times (0.5 + 0.4)] = 7.2 \text{ m}^2$$

The thermal transmittance is related to the surface area of the ductwork, not to the outer surface area of the insulation. The air has already cooled such that at (I) its temperature is  $29.85 \text{ }^\circ\text{C}$ . In the first instance, it is assumed that this remains constant through I–J. Hence, using equation 3.2, the heat loss is given by:

$$\phi = U A_s (t_{\text{ad}} - t_{\text{as}}) = 0.64 \times 7.2 (29.85 - 20) = 45.3 \text{ W}$$

The temperature drop along duct run I–J is:

$$t_{\text{ad1}} - t_{\text{ad2}} = \phi / (q_m c_p) = \phi / (q \rho c_p)$$

where  $t_{\text{ad1}}$  is the temperature at the beginning of the duct run ( $^\circ\text{C}$ ),  $t_{\text{ad2}}$  is the temperature at the end of the duct run ( $^\circ\text{C}$ ),  $\phi$  is the heat flux (W),  $q_m$  is the mass flow rate ( $\text{kg}\cdot\text{s}^{-1}$ ),  $c_p$  is the specific heat capacity of air ( $\text{J}\cdot\text{kg}^{-1}\cdot\text{K}^{-1}$ ),  $q$  is the

**Table 2.A5.7** Leakage calculations for the supply duct along the index run

Item	Length / m	Dimensions / (mm $\times$ mm)	Duct surface area, $A_s$ / m <sup>2</sup>	Total pressure at start of run, $p_1$ / Pa	Pressure loss, $\Delta p$ / Pa	( $1/2 \rho c^2$ ) / Pa	Mean static pressure, $p$ / Pa	Leakage, $q_L$ / l·s <sup>-1</sup>
<i>(a) Main duct run</i>								
E–F	2	1200 $\times$ 600	7.2	59.7	0	2.4	57.3	2.50
G–I	15	500 $\times$ 400	27	57.4	16	20.9	29.8	5.96
I–J	4	500 $\times$ 400	7.2	41.1	3.0	14.5	25.1	1.46
J–K	4	500 $\times$ 400	7.2	38.1	1.2	5.22	32.3	1.72
K–L	1	500 $\times$ 400	1.8	36.7	0.1	2.32	34.3	0.45
L–Q	20.4	400	25.6	33.2	7.7	5.88	23.5	4.98
Q–S	5	400	6.3	24.5	0.4	1.5	22.8	1.20
S–V6	3	315	2.97	23.5	1.0	3.96	19.0	0.50
<i>(b) Branch duct runs</i>								
I–V1	3	315	2.97	24.1	1.0	3.96	19.6	0.51
Similar calculations for remaining branches								1.51*
<b>Total:</b>								<b>20.79</b>

\* Notional value for sum of air leakage from remaining branches, for purposes of example calculation

**Table 2.A5.8** Heat loss calculations for uninsulated supply duct along the index run ( $U = 7.89 \text{ W}\cdot\text{m}^{-2}\cdot\text{K}^{-1}$ )

Item	Length / mm	Dimensions / (mm $\times$ mm)	Flow rate, $q$ / m <sup>3</sup> ·s <sup>-1</sup>	Duct surface area, $A_s$ / m <sup>2</sup>	Temp. at start of run, $t_{\text{ad1}}$ / $^\circ\text{C}$	Temp. diff. ( $t_{\text{ad1}} - t_{\text{as}}$ ) / K	Heat flux, $\phi$ / W	Temp. diff.* ( $t_{\text{ad1}} - t_{\text{ad2}}$ ) / K
E–F	2	1000 $\times$ 600	1.2	6.4	30	9.83	496	0.34
G–I	15	500 $\times$ 400	1.2	27	29.66	8.95	1917	1.33
I–J	4	500 $\times$ 400	1.0	7.2	28.33	8.14	464	0.32
J–K	4	500 $\times$ 400	0.6	7.2	28.01	7.70	437	0.61
K–L	1	500 $\times$ 400	0.4	1.2	27.40	7.33	69	0.15
L–Q	20.4	400 (diam.)	0.4	25.6	27.25	5.77	1210	2.52
Q–S	5	400 (diam.)	0.2	6.3	24.73	4.30	214	0.89
S–T	3	315 (diam.)	0.2	3.0	23.84	3.64	87	0.36
T	—	—	—	—	23.48	—	—	—
<b>Totals:</b>							<b>4984</b>	<b>6.52</b>

\* Temperature difference between beginning and end of duct run

volumetric flow rate ( $\text{m}^3\cdot\text{s}^{-1}$ ) and  $\rho$  the density of the air ( $\text{kg}\cdot\text{m}^{-3}$ ).

Therefore:

$$t_{\text{ad1}} - t_{\text{ad2}} = 45.3 / (1.0 \times 1.16 \times 1.030 \times 103) = 0.04 \text{ K}$$

The temperature at (J) is:

$$t_{\text{a2}} = 29.85 - 0.04 = 29.81^\circ\text{C}$$

Hence, mean temperature in duct I–J =  $\frac{1}{2}(29.85 + 29.81) = 29.83^\circ\text{C}$ .

In principle, the heat loss  $\phi$  should be re-calculated at the mean temperature, but in this instance the difference is trivial and may be ignored.

Note that though the heat loss from the next duct run J–K is the same (i.e. 45 W), the temperature drop is greater (0.06 K as opposed to 0.04 K). This is because, although the air temperature in the duct is almost the same, the airflow through section J–K is appreciably less (i.e.  $0.6 \text{ m}^3\cdot\text{s}^{-1}$  as opposed to  $1.0 \text{ m}^3\cdot\text{s}^{-1}$ ).

In summary, Table 2.A5.9 shows that the total heat loss from the index run is 522 W, the temperature drop is 0.83 K and the supply air temperature to V6 is  $29.2^\circ\text{C}$ . This is sufficiently close to the required supply temperature at V1 of  $29.8^\circ\text{C}$  for there to be no significant control problems. However the delivered heat to zone V6 is reduced by 8%, therefore there is a case for increasing the design outlet temperature of the air handling unit from  $30^\circ\text{C}$  to  $30.5^\circ\text{C}$ .

## 2.A5.5 Effects on airflows when closing down one branch

Figure 2.A5.3 shows a simplified duct network where boxes 1, 2 and 3 represent the ductwork circuits for supplying three zones. Box 5 represents the return ductwork. D is a damper which is initially open, but which will be closed down.

The design conditions are as follows:

- duct system 1:  $q = 0.2 \text{ m}^3\cdot\text{s}^{-1}$ ;  $\Delta p = 70 \text{ Pa}$
- duct system 2:  $q = 0.2 \text{ m}^3\cdot\text{s}^{-1}$ ;  $\Delta p = 50 \text{ Pa}$
- duct system 3:  $q = 0.2 \text{ m}^3\cdot\text{s}^{-1}$ ;  $\Delta p = 40 \text{ Pa}$
- duct system 4:  $q = 0.4 \text{ m}^3\cdot\text{s}^{-1}$ ;  $\Delta p = 20 \text{ Pa}$

— duct system 5:  $q = 0.6 \text{ m}^3\cdot\text{s}^{-1}$ ;  $\Delta p = 20 \text{ Pa}$

— damper D:  $q = 0.2 \text{ m}^3\cdot\text{s}^{-1}$ ;  $\Delta p = 10 \text{ Pa}$

From the above design requirement, the fan must produce a pressure rise of 70 Pa for a volume flow of  $0.6 \text{ m}^3\cdot\text{s}^{-1}$ .

We can use the approximate simplification that the pressure drop of the system is proportional to the square of the velocity, and thus proportional to the square of the flow rate. (Note: not true where there are HEPA filters in the system). Thus pressure drop at any flow rate is easily obtained using:

$$\Delta p \propto q^2 \quad (2.A5.3)$$

where  $\Delta p$  is the pressure drop (Pa) and  $q$  is the volumetric flow rate ( $\text{m}^3\cdot\text{s}^{-1}$ ).

Hence, from such values the 'system characteristic' can be constructed as shown in Figure 2.A5.4.

A fan would be chosen such that the intersection of the fan characteristic and the system characteristic gives the design requirement, as shown, of  $0.6 \text{ m}^3\cdot\text{s}^{-1}$  and a total pressure drop  $\Delta p_t$  of 70 Pa.

The following illustrates what happens to the flow in the various branches of the system when the resistance of one branch is changed as a result of closing damper D.

The problem can be resolved using either circuit resistances or capacities. Since valve manufacturers always give valve capacities, the following uses the capacity method for consistency. (See also Guide C, section 4, Appendix 4.A5.)

Capacity  $K$  is given by the relationship:

$$q = K \Delta p_p \quad (2.A5.4)$$

where  $K$  is the capacity ( $\text{m}^3\cdot\text{s}^{-1}\cdot\text{Pa}^{-0.5}$ )

Using equation 2.A5.4, the capacity of each leg of the network can be calculated, as follows:

$$K_1 = q_1 / \Delta p_{p1} = 0.2 / \div 70 = 0.02390 \text{ m}^3\cdot\text{s}^{-1}\cdot\text{Pa}^{-0.5}$$

$$K_2 = q_2 / \Delta p_{p2} = 0.2 / \div 50 = 0.02828 \text{ m}^3\cdot\text{s}^{-1}\cdot\text{Pa}^{-0.5}$$

$$K_3 = q_3 / \Delta p_{p3} = 0.2 / \div 40 = 0.03162 \text{ m}^3\cdot\text{s}^{-1}\cdot\text{Pa}^{-0.5}$$

$$K_4 = q_4 / \Delta p_{p4} = 0.4 / \div 20 = 0.08944 \text{ m}^3\cdot\text{s}^{-1}\cdot\text{Pa}^{-0.5}$$

$$K_5 = q_5 / \Delta p_{p5} = 0.6 / \div 20 = 0.13416 \text{ m}^3\cdot\text{s}^{-1}\cdot\text{Pa}^{-0.5}$$

**Table 2.A5.9** Heat loss calculations for insulated supply duct along the index run ( $U = 0.64 \text{ W}\cdot\text{m}^{-2}\cdot\text{K}^{-1}$ )

Item	Length / mm	Dimensions / (mm × mm)	Flow rate, $q / \text{m}^3\cdot\text{s}^{-1}$	Duct surface area, $A_s / \text{m}^2$	Temp. at start of run, $t_{\text{ad1}} / ^\circ\text{C}$	Temp. diff. $(t_{\text{ad1}} - t_{\text{ad2}}) / \text{K}$	Heat flux, $(\phi / \text{W})$	Temp. diff.* $(t_{\text{ad1}} - t_{\text{ad2}}) / \text{K}$
E–F	2	1000 × 600	1.2	6.4	30	9.99	41	0.03
G–I	15	500 × 400	1.2	27	29.97	9.91	171	0.12
I–J	4	500 × 400	1.0	7.2	29.85	9.83	45	0.04
J–K	4	500 × 400	0.6	7.2	29.81	9.78	45	0.06
K–L	1	500 × 400	0.4	1.2	29.75	9.74	7	0.02
L–Q	20.4	400	0.4	25.6	29.73	9.56	157	0.33
Q–S	5	400	0.2	6.3	29.40	9.32	38	0.16
S–T	3	315	0.2	3.0	29.24	9.20	18	0.07
T	—	—	—	—	29.17	—	—	—
Total:							522	0.83

\* Temperature difference between beginning and end of duct run

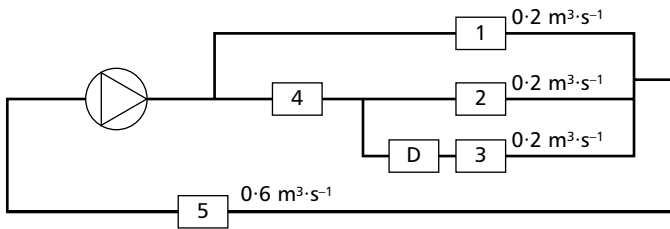

Figure 2.A5.3 Simplified duct network

With damper D closed, no flow will pass through leg 3.

$K_2$  and  $K_4$  are in series, giving an effective capacity of  $K_{2,4}$ , i.e:

$$\frac{1}{K_{2,4}^2} = \frac{1}{K_2^2} + \frac{1}{K_4^2} = \frac{1}{0.02828^2} + \frac{1}{0.08944^2}$$

Hence:

$$K_{2,4} = 0.02696 \text{ m}^3 \cdot \text{s}^{-1} \cdot \text{Pa}^{-0.5}$$

$K_{2,4}$  and  $K_1$  are in parallel, i.e:

$$\begin{aligned} K_{1,2,4} &= K_{2,4} + K_1 \\ &= 0.02696 + 0.02390 = 0.05086 \text{ m}^3 \cdot \text{s}^{-1} \cdot \text{Pa}^{-0.5} \end{aligned}$$

The total system capacity  $K_0$  is the result of  $K_{1,2,4}$  in series with  $K_5$ , i.e:

$$\frac{1}{K_0^2} = \frac{1}{K_{1,2,4}^2} + \frac{1}{K_5^2} = \frac{1}{0.05086^2} + \frac{1}{0.13416^2}$$

Hence:

$$K_0 = 0.04756 \text{ m}^3 \cdot \text{s}^{-1} \cdot \text{Pa}^{-0.5}$$

Had the capacity been calculated for the original system, it would have been found to be  $0.0717 \text{ m}^3 \cdot \text{s}^{-1} \cdot \text{Pa}^{-0.5}$ .

A new system characteristic can now be determined from equation 2.A5.4 using the calculated value of  $K_0$ , e.g. for  $q = 0.55 \text{ m}^3 \cdot \text{s}^{-1}$ :

$$\Delta p = (0.55 / 0.04756)^2 = 133.7 \text{ Pa}$$

With the damper closed, the system has a new system characteristic, see Figure 2.A5.4. The intersection with the fan characteristic now gives a flow of  $0.516 \text{ m}^3 \cdot \text{s}^{-1}$  and a pressure drop of  $\Delta p = 117.7 \text{ Pa}$ .

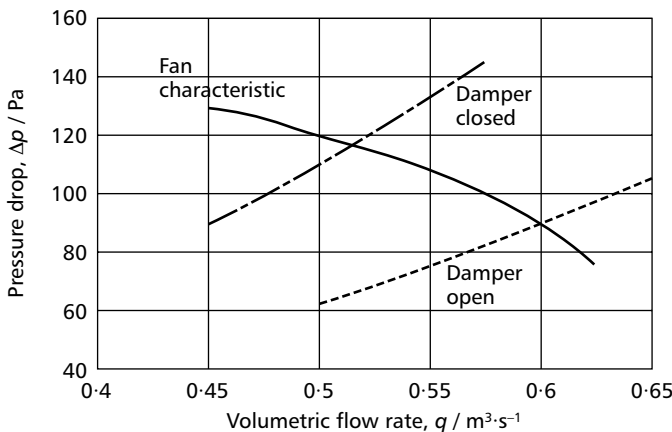

Figure 2.A5.4 System characteristic for simplified duct network; (a) characteristic with damper D open and (b) characteristic with damper D closed

It is now necessary to ascertain the proportions in which this total flow is apportioned between supply legs 1 and 2.

Knowing the flow through leg 5 (being either the return ductwork, or extract to the outside and inlet from the outside), the pressure loss through leg 5 can be calculated using equation 2.A5.4:

$$0.55 = 0.13416 \div \Delta p_5$$

Hence:

$$\Delta p_5 = (0.55 / 0.13416)^2 = 16.8 \text{ Pa}$$

The remainder is the pressure drop existing across leg 1, and across leg 4/2:

$$\Delta p_1 = \Delta p_0 - \Delta p_5 = 117.7 - 16.8 = 100.9 \text{ Pa}$$

The flow through leg 1 can now be determined using equation 2.A5.4:

$$q_1 = 0.02390 \div 100.9 = 0.2401 \text{ m}^3 \cdot \text{s}^{-1}$$

The rest of the flow passes along leg 4/2, i.e:

$$q_4 = q_0 - q_5 = 0.516 - 0.240 = 0.276 \text{ m}^3 \cdot \text{s}^{-1}$$

The flow rates resulting from closure of damper D are shown on Figure 2.A5.5.

It should be noted that, although the supplies to legs 1 and 2 were initially equal, this is no longer the case once any change is made to any other branch.

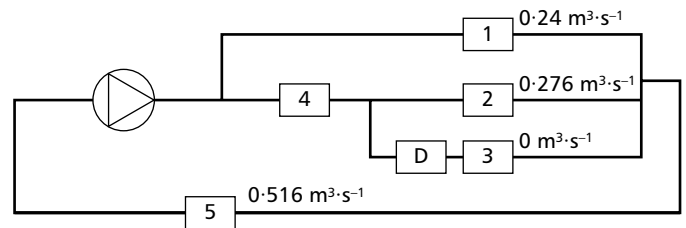

Figure 2.A5.5 Duct network with damper D closed

## References

CIBSE (2007) *Reference data* CIBSE Guide C (London: Chartered Institution of Building Services Engineers)

BESA (2013) *Specification for Sheet Metal Ductwork* DW/144 (Penrith: BESA)

NBS (2013) *The Building Regulations 2000 Approved Document L: Conservation of fuel and power* (London: The Stationery Office)

## Appendix 2.A6: Techniques for assessment of ventilation

### 2.A6.1 General

There are a number of assessment techniques available to calculate ventilation and cooling requirements and to look in detail at air movement. This appendix provides an overview of some of these techniques. CIBSE AM11 (2015a) and AM10 (2005) provide more detail on dynamic thermal simulation and assessment techniques for natural ventilation respectively.

### 2.A6.2 Ventilation and cooling

Section 2.2 includes airflow rate requirements for ventilation purposes. Airflow rate requirements for cooling purposes are normally based either on restricting peak summer temperatures in passive buildings or to meet the peak cooling load. Analyses may start by looking at peak temperatures to evaluate of the building's potential without mechanical cooling. These would assess the ventilation rates (natural and/or mechanical) and passive measures needed to meet summer temperature limits. Where cooling is to be provided, the cooling needed to maintain the temperature limits would be assessed. Airflow rates may then be calculated to deliver this cooling to the space.

There is a range of analysis methods available to suit different applications and stages in the design process. Design charts based on parametric analysis may be used (e.g. the BRE's *Environmental Design Guide*, 1998), although the user can work only within the range of variables covered by the charts. Section 5 of CIBSE Guide A (2015b) provides design information on the use of thermal dynamic models for calculating peak summertime temperatures and peak space cooling loads. Simple (dynamic) models (e.g. the admittance procedure) may be used to assess cooling loads and the probability of overheating. These approaches are based on a 24-hour design cycle and are suitable for mechanically cooled buildings with a repetitive diurnal operating cycle. However, where this is not an accurate reflection of building operation due to thermal mass or passive operation, dynamic thermal simulation may be used.

Appropriate consideration should be given to issues of weather data, control and thermal mass depending on the application. Selection of appropriate weather data is discussed in CIBSE AM10 (2005). Different data will be required for different purposes. For example, to estimate energy consumption, average weather data for the region will usually be the most appropriate. Data, including more extreme conditions, will be appropriate to test the ability of the building to accommodate various levels of internal heat gain and predict peak temperatures. Site-specific weather data can be of interest, but may have been collected over a relatively short period and may not necessarily be representative. It is frequently impossible to use such data to construct meaningful statistics to identify the percentage of time a specified internal temperature would be likely to be exceeded. There is also a danger that the design may lack robustness, being tailored to a unique weather sequence and reacting in a different and unpredicted way to more

normal weather peaks. A more robust choice will often be to analyse the building in relation to appropriate national UK data and to make simple corrections to suit the differences between this and the site data; e.g. August average temperature and diurnal swing and August 2.5% exceeded peak temperature and the associated diurnal swing.

Loads and system performance often depend on more than one weather variable. Cooling and humidity conditions will be a function of wet bulb as well as dry bulb temperature. The performance of natural ventilation systems in particular can be affected by solar and wind conditions as well as temperatures, as these are often used to drive the ventilation. Design conditions for the individual weather variables will rarely coincide.

Controls used in the thermal model should reflect what can be expected to occur in practice. This is a particular issue in natural ventilation systems with manual control. Account should be taken of the way occupants use windows. Data are available on occupancy effects on natural ventilation, primarily based on the domestic sector. This work is summarised in AIVC Technical Note 23 (Dubrul, 1988).

Thermal mass should be modelled with appropriate surface heat transfer values and representation of heat flow within the mass. High thermal mass buildings must be allowed to come to their natural thermal equilibrium by having a lengthy period of simulation prior to the period over which the modelling results are reported and compared; 15 days is usually enough for this 'pre-conditioning' period, although a few buildings require longer. This can be tried first with 10 and 20 days and the results compared to check for significant differences. If a hot spell is being simulated, peak weather data should not be used throughout, as this will under-value the heat-absorbing benefits of the thermal mass. Instead, pre-conditioning with average weather for the season concerned can be undertaken, followed by a step change to the peak weather sequence — which in the UK seldom lasts more than 5 days. The design day is typically the third in the peak weather sequence.

### 2.A6.3 Air movement

Analyses of air movement may be needed, particularly for natural ventilation applications and air movement in large spaces such as atria. These provide information on air velocity, movement and temperature; volume flow rate; and optimal opening sizes, shapes and positions. Techniques available include computational fluid dynamics (CFD), physical models and air flow models. For room air distribution, performance is sometimes critically dependent on details of equipment design, and full-scale mock-ups may be required.

#### 2.A6.3.1 Computational fluid dynamics (CFD)

CFD is a technique for predicting air movement that can address questions such as stratification and local air

movement. It therefore has particular application to consideration of large spaces such as atria. CFD methods can predict temperature and velocity distributions in a space and can be applied to assessments of comfort involving more of the influencing parameters than is possible in zonal models. Because of the extensive nature of the computations and the time varying nature of the natural driving forces, CFD is normally only used to generate 'snapshots' of how the design would work at a given point in time.

Another potential application for CFD is external flows around the building. The purpose is to generate the wind pressure coefficients needed by all models to predict natural airflow rates.

### 2.A6.3.2 Physical models

Physical models are especially useful for giving the non-technical members of the client and design team a good visualisation of airflow behaviour. By their nature, physical models are implicit design tools; assumptions need to be made then tested. The two main techniques relating to natural ventilation design are the salt bath technique and wind tunnel testing.

#### *Salt bath*

The salt bath technique is used to test stack driven ventilation strategies. Stack-driven flows are analysed at small scale in the laboratory using a model of the building immersed in a perspex bath containing saline solutions of different concentrations. The method models fluid flow, not surface heat transfer, and therefore cannot predict local effects such as solar patching on the floor of an atrium. Like the CFD technique it provides only a snapshot of performance.

#### *Wind tunnel*

Wind tunnel testing is the main source of information on wind pressure coefficients. It is not a method for proving the design of a natural ventilation system, since it only deals with external flows around a building.

#### *Air flow models*

Air flow models may be used to analyse natural ventilation air flow rates based on driving pressure differences and openings. These range from single zone models to more complex multi-zone models. Single zone models (Liddament, 1996) are appropriate where the building is open plan and there is no temperature stratification in the space. Building types that approximate to these requirements are dwellings, many industrial buildings and small open plan office buildings. Multi-zone models subdivide the building into a number of individual spaces, substantially increasing the complexity of the analysis (Feustel, 1991).

Software combining multi-zone flow models with thermal simulation analysis is also available. This software can provide an integrated analysis the internal temperature distribution and the stack induced natural ventilation flow rates (Kendrick, 1993).

## References

- CIBSE (2005) *Natural ventilation in non-domestic buildings* CIBSE Applications Manual AM10 (London: Chartered Institution of Building Services Engineers)
- CIBSE (2015a) *Building energy and environmental modelling* CIBSE Applications Manual AM11 (London: Chartered Institution of Building Services Engineers)
- CIBSE (2015b) *Environmental design* CIBSE Guide A (London: Chartered Institution of Building Services Engineers)
- Dubrul C (1988) *Inhabitant's behaviour with regard to ventilation* AIVC Technical Note 23 (Coventry: Air Infiltration and Ventilation Centre)
- Feustel H E and Dieris (1991) *A Survey of air flow models for multi-zone structures* (Berkeley, CA: Earnest Orlando Lawrence Berkeley National Laboratory)
- Kendrick J (1993) *An overview of combined modelling of heat transport and air movement* AIVC Technical Note 40 (Coventry: Air Infiltration and Ventilation Centre)
- Liddament M W (1996) *Air Infiltration Development Algorithm (AIDA)* Appendix 3 in *A guide to energy efficient ventilation* (Coventry: Air Infiltration and Ventilation Centre)
- Rennie D and Parand F (1998) *Environmental design guide for naturally ventilated and daylit offices* BRE Report BR 345 (Garston: Building Research Establishment)

# Index

*Note: page numbers in italics refer to figures; page numbers in bold refer to tables*

- access doors and panels 2-112 to 2-113, 2-115, **2-118**, 2-119
- acoustic dampers 2-109, *2-110*
- acoustic design 2-57, 2-80, **2-80**, 2-109  
*see also* noise
- acoustic trickle ventilators 2-108
- actuators 2-49, 2-50
- adsorption filters 2-27, **2-29**
- aerofoil blades **2-88**, 2-89
- aesthetic considerations 2-36, 2-39 to 2-40
- air bricks 2-108
- air change rates
  - calculation 2-73
  - definition 2-3
  - domestic mechanical ventilation 2-22
  - and draughts 2-60
  - ductwork sizing 2-36, 2-67
  - measurement 2-76 to 2-77
  - natural ventilation 2-55, 2-56
  - typical for types of terminal unit **2-61**
- air cleaners *see* filtration systems
- air conditioning 2-10, 2-19, 2-50, 2-60
- air control units 2-92 to 2-93  
*see also* fans; volume controllers
- air discharge 2-94 to 2-96
  - minimising re-entry 2-96
  - pollution control 2-96
  - position of 2-83, 2-95
- air distribution methods 2-11 to 2-12
- air entrainment 2-60, 2-98, **2-99**
- air flow *see* airflow
- air handling units (AHUs) 2-135, 2-139 to 2-140
- air infiltration 2-3, 2-73  
*see also* airtightness
- air intakes 2-94 to 2-96
  - minimising re-entry 2-96
  - position of 2-83, 2-94 to 2-95
  - pressure loss 2-134, 2-137 to 2-138, **2-140**
- air jet flow 2-59 to 2-62
- air leakage 2-84 to 2-87
  - calculation 2-141, **2-142**
  - detection 2-76
  - limits 2-37 to 2-38, **2-38**, 2-84 to 2-85, **2-85**, 2-132
  - as a percentage of total air volume 2-85
  - in relation to air pressure 2-84, 2-86
  - testing 2-37, 2-76 to 2-77, 2-85 to 2-86
- air pollution control 2-96
- air quality *see* airborne contaminants; indoor air quality; outdoor air pollution
- air supply 2-58
- air terminal devices
  - access provision 2-130, *2-131*
  - airflow measurements 2-78 to 2-79
  - duct and plenum connections 2-47 to 2-48
  - flow phenomena 2-59
  - large building 'balanced' mechanical ventilation 2-19
  - location and layout 2-60 to 2-61, 2-62, **2-63**, 2-94
  - maximum air change rates **2-61**
  - types 2-94, **2-95**
  - see also* diffusers; volume controllers
- air volume control *see* volume airflow rate control
- airborne contaminants 2-25, 2-119
  - calculation of concentrations 2-73
  - control 2-8 to 2-9
- airflow
  - around buildings 2-55, 2-79
  - calculations 2-72, 2-72 to 2-75, 2-145 to 2-146
  - distribution in a space 2-77 to 2-78
  - in ducts 2-42 to 2-44, 2-78 to 2-79
  - measurements 2-77 to 2-79, **2-113**
  - test holes 2-115 to 2-116
  - models 2-146
  - through openings 2-73, 2-74
  - through terminal units 2-78 to 2-79
  - throughout a building 2-72
  - see also* room air diffusion; volume airflow rate control
- air-quality sensors 2-50
- airtightness 2-3, **2-6**, 2-7, 2-55
  - classification of doors and windows 2-105, 2-106, **2-106**
  - definition 2-3
  - domestic mechanical ventilation 2-22
  - ductwork 2-76
  - estimating air infiltration rate 2-73
  - testing 2-75, 2-76, 2-86 to 2-87
  - see also* air leakage
- anemometry 2-78
- assessment techniques 2-145 to 2-146
- atrium ventilation 2-15 to 2-17
- axial-flow fans 2-39, 2-87, **2-88**
  - connections to ductwork 2-104, 2-104
- backwards-curved blades **2-88**, 2-89
- basements 2-83
- bends in ductwork 2-100, *2-101*, 2-102
  - pressure loss 2-135, 2-136, 2-137, **2-138**, **2-139**
- bifurcated fans 2-89
- biocides 2-27
- bird mesh 2-134
- blending (temperature control) 2-50, 2-93
- blinds 2-106 to 2-107  
*see also* solar shading
- blower doors 2-3, 2-75, 2-76, 2-87
- branches in ductwork 2-100 to 2-101, *2-102*
  - pressure loss 2-134 to 2-135, 2-135 to 2-136, **2-138**, **2-139**
- BREEAM 2-52 to 2-53
- building design considerations 2-36, 2-41, 2-66
  - building fabric 2-6, 2-7, 2-54, 2-63 to 2-64
  - building location 2-6
  - building orientation 2-6, 2-54
  - building shading 2-54
  - building spacing 2-54
  - building structure and form 2-6, 2-36, 2-41, 2-54
  - pressure distribution and airflow around buildings 2-79
- building log books 2-114
- Building Regulations
  - Part B 2-34, 2-81, 2-83
  - Part C 2-11
  - Part F 2-10, 2-20, 2-22, 2-108, 2-112
  - Part J 2-21, 2-40, 2-81
  - Part L 2-3, 2-34, 2-38, 2-41, 2-51, 2-70, 2-76, 2-84, 2-112, 2-140
- buoyancy-driven ventilation *see* stack-driven ventilation
- calculation techniques 2-71 to 2-75, 2-133 to 2-144
- canopies 2-96, **2-97**, **2-99**
- capital allowances 2-3
- car parks 2-83
- carbon dioxide *see* CO<sub>2</sub>
- carbon emissions 2-3
- CE marking 2-81
- ceiling diffusers 2-60, **2-61**, 2-61 to 2-62, **2-63**
- ceiling-mounted terminal units 2-130, *2-131*
- centrifugal fans 2-38 to 2-39, 2-87, **2-88**, 2-89
  - connections to ductwork 2-103, 2-104
- chimney-driven ventilation *see* stack-driven ventilation
- circular ducting 2-99, **2-118**, 2-129
  - cleaning 2-113, 2-114 to 2-121
- cleanliness quality classification 2-119, **2-120**
- Climate Change Levy 2-3
- climate variability 2-57
- CO<sub>2</sub>, metabolic 2-9
- CO<sub>2</sub> emissions 2-3
- CO<sub>2</sub> sensing control 2-52
- CO<sub>2</sub> sensors 2-49, 2-50
- Coanda effect 2-61
- comfort cooling 2-54, 2-145
- commissioning 2-111 to 2-116
- computational fluid dynamics (CFD) 2-74 to 2-75, 2-79, 2-145 to 2-146
- condensate traps 2-22
- condensation 2-10 to 2-11, 2-44, 2-46, 2-103, 2-120
- condition-based maintenance 2-28
- constant pressure drop 2-67 to 2-68
- contaminant removal efficiency 2-3
- contaminants *see* airborne contaminants
- contractions in ducts 2-102, *2-103*, 2-135, 2-136
- control systems 2-48 to 2-52
  - air conditioning 2-50
  - displacement ventilation 2-51
  - energy efficiency 2-51 to 2-52
  - fire dampers 2-52, 2-82, 2-84
  - mixed-mode ventilation 2-50 to 2-51, 2-65
  - natural ventilation 2-50, 2-57
  - temperature control 2-50
  - volume airflow rate 2-49 to 2-50, 2-92 to 2-93, 2-114
- cooker hoods 2-21
- cooling load 2-12, 2-54, 2-145
- cooling temperature differentials 2-60, **2-61**
- cost considerations 2-3, 2-41, **2-47**, 2-48
- cross-flow fans **2-88**, 2-89
- cross-flow ventilation 2-17, 2-18, 2-53, 2-107
- dampered openings 2-109
- dampers
  - fan volume flow control 2-49, 2-93
  - inspection covers 2-113
  - natural ventilation openings 2-50, 2-109
  - pressure loss 2-134, 2-135, **2-138**, **2-139**
  - provision and siting of 2-114 to 2-115
  - see also* fire dampers
- decision-making process 2-53
- demand-controlled ventilation 2-92 to 2-93
- depth of plan 2-17 to 2-18, 2-37, 2-53
- design calculation techniques 2-71 to 2-75
- design criteria 2-4 to 2-12
- design options 2-53, 2-64 to 2-65
- design process 2-53 to 2-54
- diffusers 2-19
  - ceiling mounted 2-60, **2-61**, 2-61 to 2-62, **2-63**
  - pressure loss 2-137
  - types 2-94, **2-95**
- dilution ventilation 2-3, 2-11
- discharge air *see* air discharge
- discharge cowls 2-105, 2-106
- discharge grilles 2-83
- discharge stacks 2-96, 2-98
- displacement ventilation 2-3, 2-11 to 2-12, 2-19, 2-51
- doors
  - classification by air permeability 2-105

- clearance beneath 2-22
  - see also* openings
- DOP (di-octylphthalates) 2-27
- double façade natural ventilation 2-17, 2-56
- draught rating (DR) 2-11
- draughts 2-11, 2-18, 2-60, 2-62
  - reduction 2-54, 2-106, 2-108
  - see also* room air diffusion
- drawings 2-114
- ductwork 2-34 to 2-48, 2-130
  - access doors and panels 2-112 to 2-113, 2-118, 2-119
  - air leakage 2-84 to 2-86
    - calculation 2-141, 2-142
    - limits 2-37 to 2-38, 2-38, 2-84 to 2-85, 2-85, 2-132
    - as a percentage of total air volume 2-85
    - in relation to air pressure 2-84, 2-86
    - testing 2-37, 2-76 to 2-77, 2-85 to 2-86
  - air velocities 2-41 to 2-42, 2-42, 2-48
  - airflow in ducts 2-42 to 2-44, 2-78 to 2-79
  - airflow measurements 2-78 to 2-79
  - anti-microbial coatings 2-27
  - basements 2-83
  - bend and duct fitting components 2-99 to 2-102
  - building design considerations 2-36, 2-41, 2-66
  - car parks 2-83
  - classification 2-34 to 2-35, 2-35
  - cleaning 2-113, 2-114 to 2-121
  - cleanliness 2-116
  - commissioning 2-111 to 2-112, 2-114, 2-116
  - condensation and vapour barriers 2-44 to 2-47
  - connections 2-103 to 2-106
  - cost considerations 2-41
  - design criteria 2-41 to 2-42
  - design issues 2-34 to 2-41
  - domestic mechanical ventilation 2-22
  - duct and plenum design 2-47 to 2-48
  - duct pressure and air velocity 2-34 to 2-35, 2-35
  - energy efficiency 2-47, 2-48
  - in escape routes 2-82, 2-84
  - fire protection 2-40, 2-81, 2-82 to 2-84
  - fire resisting 2-40, 2-81, 2-82, 2-84, 2-103, 2-132
  - health and safety 2-42
  - heat gains and losses 2-43 to 2-44, 2-45, 2-141 to 2-142, 2-142, 2-143
  - industrial extract equipment 2-98
  - installation 2-116
  - instrument connections 2-115
  - insulation 2-44 to 2-46, 2-45, 2-46, 2-84, 2-103, 2-142 to 2-143
  - kitchen extract systems 2-82
  - layout and spatial requirements 2-35 to 2-36, 2-65 to 2-66, 2-130
  - maintenance 2-39, 2-114 to 2-121
  - natural ventilation 2-55, 2-109
  - noise 2-39, 2-48, 2-71, 2-79 to 2-81
  - performance requirements 2-41
  - pressure loss 2-67 to 2-71, 2-133 to 2-137, 2-138, 2-139
  - pressurisation systems 2-83
  - section types 2-98 to 2-99
  - sizing 2-36, 2-67 to 2-71, 2-128 to 2-129, 2-133 to 2-137
  - support and fixing 2-102 to 2-103, 2-132
  - test holes 2-115 to 2-116, 2-117
  - visual inspection 2-120
- dust collectors 2-28
- dust deposition 2-119
- dusts *see* particulates
- EC-type motors 2-93
- electrostatic air cleaners 2-29
- employees performance 2-4
- energy efficiency 2-3
  - control systems 2-51 to 2-52
  - ductwork 2-38, 2-39, 2-47, 2-48
  - heat recovery systems 2-31, 2-31 to 2-32
  - mixed-mode ventilation 2-65
- Energy Labelling Directive 2-91
- Energy Performance of Buildings Directive 2-3, 2-92
- enhanced capital allowance scheme 2-3
- ErP (Ecodesign of Energy-related Products) Directive 2-91
- escape routes 2-82, 2-84
- evaporator temperature 2-60
- exhaust air *see* air discharge
- exhaust hoods 2-21, 2-96 to 2-98, 2-97, 2-99
- exhaust stacks 2-96, 2-98
- exhaust terminals 2-62
- expansions in ducts 2-101, 2-103, 2-134
- exposure limits 2-9
- external louvres 2-106, 2-109, 2-134
- external noise 2-55, 2-57, 2-79 to 2-80
- external pollution 2-6, 2-8 to 2-9, 2-18, 2-119
- false ceilings 2-130, 2-131
- fan/motor efficiency grades (FMEG) 2-91
- fans 2-87 to 2-92
  - connections to ductwork 2-103 to 2-104
  - efficiency 2-38 to 2-39, 2-91, 2-92
  - fan laws 2-91
  - fire rating 2-82, 2-83
  - industrial extract equipment 2-98
  - installation categories 2-91
  - mechanical extract ventilation 2-20 to 2-21
  - mechanical supply ventilation 2-21 to 2-22
  - outlet pressure 2-90
  - performance 2-89 to 2-91
  - sizing 2-139 to 2-140
  - specific fan power (SFP) 2-38 to 2-39, 2-70, 2-140 to 2-141
  - terms and definitions 2-89 to 2-91
  - types and components 2-87 to 2-89, 2-88
- fibrous materials 2-42
- filtration systems 2-25 to 2-30
  - access panels 2-113
  - application and selection 2-27 to 2-28
  - classification 2-25 to 2-27, 2-26, 2-27, 2-29
  - gas and vapour removal 2-27
  - installation 2-30
  - maintenance 2-28, 2-30, 2-39, 2-119, 2-120
  - particulates removal 2-25 to 2-27, 2-28
  - pressure drops 2-30, 2-31, 2-32
  - specification data 2-30
  - terms and definitions 2-25
  - testing 2-25 to 2-27
- fire dampers 2-22, 2-40, 2-66, 2-81, 2-82, 2-83
  - to 2-84, 2-132
  - access panels 2-112 to 2-113, 2-130, 2-131
  - control systems 2-52, 2-82, 2-84
  - in escape routes 2-82
  - pressure loss 2-136
- fire doors 2-40
- fire protection 2-40, 2-57, 2-81 to 2-84, 2-118, 2-120, 2-132
- fire-resisting ductwork 2-40, 2-81, 2-82, 2-103, 2-132
- fire-resisting enclosures 2-132
- flat oval ducting 2-99
- flexibility of design 2-57, 2-64
- floor-to-ceiling height ratio 2-54
- flow hoods 2-79
- flume models 2-78
- FMEG (fan/motor efficiency grades) 2-91
- forward-curved centrifugal fans 2-88, 2-89
- fresh air supply rates 2-9 to 2-10, 2-10
- friction loss method 2-67 to 2-68, 2-70
- gas sensors 2-49
- glazing 2-6
  - see also* openable windows; windows
- glazing ratios 2-54
- guide vanes 2-39, 2-87
- hand holes in ductwork 2-113
- handover 2-116, 2-119
- hangers 2-102, 2-132
- hazardous areas 2-83
- hazardous substances 2-120
- health and safety 2-42, 2-119
- heat gains and losses
  - building design features 2-54, 2-54
  - ductwork 2-43 to 2-44, 2-45, 2-141 to 2-142, 2-142, 2-143
  - internal heat gains 2-7
- heat pipes 2-31, 2-33
- heat recovery systems 2-30 to 2-34
  - access panels 2-113
  - advantages and disadvantages 2-33
  - definition 2-3
  - domestic mechanical ventilation 2-22, 2-23
  - efficiency 2-31, 2-31 to 2-32
  - mechanical extract ventilation 2-21, 2-23
  - types 2-31, 2-32 to 2-33
- hoods *see* exhaust hoods
- horizontal ductwork 2-102
- horizontal pivot windows 2-107
- horizontal sliding windows 2-107
- hot wire anemometry 2-78
- humidity control 2-10, 2-21, 2-60
- humidity controlled vents 2-108
- humidity sensing control 2-52
- humidity sensors 2-49, 2-50
- hybrid ventilation *see* mixed-mode ventilation
- impeller power 2-90
- impellers (fans) 2-87
- indoor air quality 2-119
  - see also* airborne contaminants
- induction-type diffusers 2-94
- industrial extract equipment 2-96 to 2-98
- inlet guide vanes 2-51, 2-87
- inlet volume flow rate 2-90, 2-91, 2-92
- inspection for cleaning 2-120
- inspection panels 2-112 to 2-113
- instrument connections 2-115
- insulation 2-6, 2-44 to 2-46, 2-45, 2-46, 2-84, 2-103, 2-142 to 2-143
- intake air *see* air intakes
- internal heat gains 2-7
- interstitial condensation 2-10 to 2-11
- jet-assisted hoods 2-98
- kitchen extract systems 2-82, 2-84
- latent heat recovery 2-3, 2-31, 2-32, 2-33
- lateral exhausts 2-96, 2-98
- legislation 2-42, 2-112, 2-117 to 2-118
- life cycle costs 2-4, 2-8
- lighting system 2-7 to 2-8
- log books 2-114
- louvres 2-106, 2-109, 2-134
- maintenance 2-114 to 2-121
  - access doors and panels 2-112 to 2-113, 2-115, 2-118, 2-119
  - ductwork 2-39, 2-114 to 2-121

- filtration systems 2-28, 2-30, 2-39, 2-119, 2-120
- heat recovery systems 2-32
- manual control 2-49, 2-57
- maximum penetration depth 2-17 to 2-18
- measurement techniques 2-55, 2-75 to 2-79
- mechanical extract ventilation 2-20 to 2-21, 2-82, 2-84
- mechanical supply ventilation 2-21 to 2-23
- mechanical ventilation 2-18 to 2-23
  - advantages and disadvantages 2-19 to 2-20
  - definition 2-1
  - displacement systems 2-19
  - domestic 'balanced' 2-22
  - large building 'balanced' 2-19
  - room air distribution design 2-58 to 2-62
  - sizing 2-58
  - strategies 2-18 to 2-19
  - system design 2-58 to 2-63
- mechanical volume controllers 2-49 to 2-50, 2-93, 2-114
- metabolic carbon dioxide 2-9
- microbial growths 2-27, 2-119, 2-120
- mists 2-28
- mitred elbows 2-100, 2-101
- mixed-flow in-line fans 2-88, 2-89
- mixed-mode ventilation 2-23 to 2-25, 2-63 to 2-65
  - control systems 2-50 to 2-51, 2-65
  - definition 2-1
  - energy efficiency 2-65
  - performance assessment 2-65
- mixing boxes 2-94
- mixing ventilation 2-3, 2-11
- models 2-146
- moisture 2-120
  - see also* condensation
- monitoring systems 2-52
- most penetrating particle size (MPPS) 2-26
- motor input power 2-90
- motor output power 2-90
- motorised dampers 2-114 to 2-115
- MPPS (most penetrating particle size) 2-26
- multiple occupied spaces 2-57
  - see also* zoned systems
- multi-vane centrifugal fans 2-88, 2-89
- natural ventilation 2-12 to 2-18
  - advantages and limitations 2-18
  - control systems 2-50, 2-57
  - cooling load 2-145
  - definition 2-1
  - design process 2-53 to 2-54
  - distribution routes 2-55, 2-64
  - equipment 2-106 to 2-111
  - night cooling 2-57
  - noise issues 2-55, 2-57, 2-80
  - options and maximum recommended depths 2-18
  - sizing of openings 2-55, 2-56
  - smoke ventilators 2-82
  - system design 2-52 to 2-57
  - ventilation rates 2-55, 2-56
  - see also* openable windows; stack-driven ventilation
- network (zonal) models 2-73 to 2-74
- night cooling 2-57
- noise 2-12, 2-79 to 2-81
  - air terminal units 2-50
  - ductwork 2-39, 2-48, 2-71, 2-80 to 2-81
  - external 2-55, 2-57, 2-79 to 2-80
  - plant 2-80 to 2-81
  - reduction methods 2-80
  - see also* acoustic design
- noise rating (NR) 2-42
- occupancy controlled ventilation 2-92 to 2-93
- occupancy heat gains 2-7
- occupancy sensing control 2-52
- occupancy sensors 2-50
- occupant comfort 2-10, 2-54, 2-58 to 2-59, 2-106
  - see also* thermal comfort
- occupant controls 2-8, 2-51, 2-57
- occupant performance 2-4
- office equipment heat gains 2-7
- openable windows
  - adjustability 2-106
  - design 2-6, 2-106 to 2-108
  - height of 2-54
  - integration with solar control 2-106 to 2-107
  - noise penetration 2-57, 2-80
  - required area 2-52 to 2-53
  - security considerations 2-57, 2-106
  - sizing 2-55, 2-56
  - types 2-107 to 2-108
  - ventilation capacity 2-106
- openings
  - flow rate calculations 2-73, 2-74
  - sizing for natural ventilation 2-55, 2-56
- orifice plates and nozzles 2-78 to 2-79
- outdoor air pollution 2-6, 2-8 to 2-9, 2-18, 2-119
- outdoor air supply *see* air intakes
- outdoor noise 2-55, 2-57, 2-79 to 2-80
- overhead canopies *see* canopies
- overheating risk 2-8, 2-18
  - see also* summer cooling load
- over-sizing 2-38, 2-92
- paddle-blades 2-88, 2-89
- parasitic loads 2-32, 2-52
- particulates
  - characteristics 2-25, 2-28
  - particulate size 2-30
  - settling rates 2-28
  - typical amounts 2-30
  - see also* filtration systems
- passive stack ventilation (PSV) *see* stack-driven ventilation
- percentage persons dissatisfied (PPD) 2-3, 2-58 to 2-59
- perfluorocarbon tracers (PFTs) 2-77
- performance requirements 2-5, 2-5 to 2-7
- photo-catalytic oxidation 2-27 to 2-28
- physical models 2-146
- pitot-static traverses 2-78 to 2-79
- plan depth *see* depth of plan
- plant rooms 2-64
- plate heat exchangers 2-32
- plenum design 2-47 to 2-48
- PMV (predicted mean vote) 2-3
- pollutant controlled vents 2-108
- pollutants *see* airborne contaminants; indoor air quality
- pollution control 2-96
- PPD (percentage persons dissatisfied) 2-3, 2-58 to 2-59
- predicted mean vote (PMV) 2-3
- pressure controlled vents 2-108
- pressure loss 2-67 to 2-71, 2-91, 2-92
  - bends in ductwork 2-100, 2-101, 2-102
  - calculation 2-133 to 2-137
  - filtration systems 2-30, 2-31, 2-32
- pressure regulating valves 2-49, 2-93
- pressurisation systems 2-83
- pressurisation tests 2-3, 2-76, 2-87
- process exhaust hoods 2-96 to 2-98
- propeller fans 2-88, 2-89
- protected shafts 2-132
- pure displacement terminals 2-94
- push-pull hoods 2-96, 2-98, 2-99
- radiused bends 2-100, 2-101, 2-101
- rain and openings 2-57
- rain sensors 2-50
- raised floors 2-130, 2-131
- rebalancing 2-121
- recirculation 2-3
- rectangular ducting 2-98, 2-118, 2-128 to 2-129
- recuperators 2-31
- regenerators 2-31, 2-33
- reheat 2-50, 2-93
- risk assessments 2-10, 2-20, 2-40, 2-118
- roof lights 2-109
- roof pressure coefficients 2-109 to 2-110
- roof ventilators 2-15, 2-109
- roof-mounted terminals 2-110
- room air diffusion 2-11, 2-58 to 2-62, 2-72, 2-77
  - see also* draughts
- run-around coils 2-31, 2-32
- salt baths 2-146
- sash windows 2-107
- sealants 2-37, 2-84, 2-103
- security considerations 2-57, 2-106
- sensors 2-48 to 2-49, 2-50
- shading 2-6, 2-54, 2-106 to 2-107
- shaft outlets 2-109
- sheet metal ductwork 2-37
- side-hung windows 2-107
- side-wall terminals 2-61
- single-sided natural ventilation 2-17, 2-56
- sizing
  - ductwork 2-128 to 2-129
  - fans 2-139 to 2-140
- sliding windows 2-107
- small power loads 2-8
- smoke dampers 2-82, 2-112 to 2-113
- smoke extract systems 2-82
- smoke methods (leak detection) 2-76
- smoke protection 2-40 to 2-41, 2-81 to 2-84, 2-83
- smokes 2-25, 2-28
- solar chimneys 2-111
- solar gains 2-7, 2-8
- solar sensors 2-50
- solar shading 2-6, 2-54, 2-106 to 2-107
- space allowances for ductwork 2-130
- specific fan power (SFP) 2-3, 2-38 to 2-39, 2-70, 2-92, 2-140 to 2-141
- speed control 2-93
- splitter bends 2-100, 2-101, 2-101, 2-135
- stack-driven ventilation 2-12 to 2-15, 2-17
  - atrium ventilation 2-12 to 2-15
  - combined with wind-driven ventilation 2-15, 2-16
  - passive stack design 2-110 to 2-111
  - roof ventilators 2-109
  - ventilation rates 2-55, 2-56
- stacks *see* discharge stacks
- stagnation pressure at a point 2-90
- standard air 2-90
- static regain method 2-67
- straight-radial blades 2-88, 2-89
- summer cooling load 2-54, 2-145
- supply air diffusion 2-58 to 2-62
- supply air temperature 2-12, 2-51, 2-60
- swirl-type diffusers 2-94
- system design 2-52 to 2-79
  - mechanical ventilation 2-58 to 2-63
  - mixed-mode ventilation 2-63 to 2-65
  - natural ventilation 2-52 to 2-57

- system options 2-53, 2-64 to 2-65
- tangential fans 2-88, 2-89
- tapered expansions in ducts 2-101, 2-103, 2-134
- task ventilation 2-3
- temperature control 2-22, 2-50, 2-93
- temperature differential 2-12, 2-58, 2-60
- temperature sensing control 2-52
- temperature sensors 2-49, 2-50
- test holes 2-115 to 2-116, 2-117
- testing 2-111 to 2-116
  - air leakage 2-37, 2-76 to 2-77, 2-85 to 2-86
  - airtightness 2-75, 2-76, 2-86 to 2-87
  - filtration systems 2-25 to 2-27
- thermal comfort 2-10, 2-54, 2-58, 2-106
- thermal mass 2-6, 2-55, 2-145
- thermal wheels 2-31, 2-32
- thermography 2-76
- tilt and turn windows 2-107 to 2-108
- tilting top vents 2-107 to 2-108
- top/bottom hung windows 2-107
- tracer gas techniques 2-76 to 2-77, 2-79
- transfer grilles 2-22, 2-110
- trickle ventilators 2-108
- turning vanes 2-100
- ultraviolet germicidal irradiation (UVGI) 2-27, 2-119
- under-floor natural ventilation 2-55, 2-64
- upgrading systems 2-57, 2-64
- user controls 2-8, 2-51, 2-57
- UVGI (ultraviolet germicidal irradiation) 2-27, 2-119
- vapour barriers 2-46 to 2-47, 2-103
- variable air volume (VAV) 2-39, 2-51, 2-114
  - see also* volume airflow rate control
- variable flow control 2-92 to 2-93
- variable pressures 2-85
- variable speed fans 2-39, 2-51
- variable supply air temperature 2-51
- VAV *see* variable air volume (VAV)
- velocity method 2-67
- ventilation effectiveness 2-3, 2-77
- ventilation options 2-6, 2-53, 2-64 to 2-65
- ventilation purposes 2-4
- ventilation rates *see* air change rates
- vertical ducts 2-102 to 2-103
- vertical pivot windows 2-107
- vertical temperature gradient 2-12, 2-58, 2-60
- viscous impingement units 2-29
- visualisation techniques 2-77
- volume airflow rate control 2-49 to 2-50, 2-92 to 2-93
  - see also* variable air volume (VAV)
- volume controllers 2-49 to 2-50, 2-93, 2-114
- whole-life cost 2-4, 2-8
- width/floor-to-ceiling height ratio 2-54
- wind effects 2-54, 2-55, 2-56, 2-95, 2-109
- wind pressure on buildings 2-79
- wind sensors 2-50
- wind towers 2-110
- wind tunnel testing 2-79, 2-146
- wind-driven natural ventilation 2-12, 2-15, 2-107
  - combined with stack-driven ventilation 2-15, 2-16
- window control 2-50
- windows
  - classification by air permeability 2-105, 2-106, 2-106
  - see also* openable windows
- work performance 2-4
- zonal models 2-73 to 2-74
- zoned systems 2-24, 2-36 to 2-37, 2-58, 2-64, 2-143 to 2-144

